



## **Assessing the Spatio-Temporal Fitness of Information Supply and Demand on Ship Bridges**

A dissertation accepted by the School of Computing Science, Business Administration,  
Economics and Law of the Carl von Ossietzky University Oldenburg (Germany)  
to obtain the degree and title

**Doctor of Engineering (Dr.-Ing.)**

by **Mr. Christian Denker, M.Sc.**  
born on 14<sup>th</sup> February 1987 in Stade

Reviewers:

Prof. Dr.-Ing. Axel Hahn  
Prof. Thomas Porathe, Ph.D.

Date of disputation: 09.06.2016

## **Abstract**

Besides environmental influences or technical faults, in up to 85% human error is the main reason for accidents in maritime transport. Accident report reviews reveal that insufficiencies in Situation Awareness (with 71%) are the main cause of these errors. In most cases, insufficiencies in Situation Awareness can be deduced back to two facts: either there was too less information or too much information available for the crew. In nowadays ship bridge design processes, the common bond of spatial distribution of information and temporal aspects of collaborative crew work is neglected. This thesis is addressing these aspects jointly: With the developed computer-supported method, spatio-temporal fitness of information supply and information demand can be assessed for navigational situations during design time of the ship bridge. The systemic baseline of this thesis' method is the theory of Distributed Situation Awareness. The method consists of three high-level steps: Modelling of an integrated spatial and collaborative process model, simulative execution of work processes within the work environment, and qualitative and quantitative analysis of a simulation run, which allows detecting misfits between information supply and demand. The methodological contribution is accompanied with three conceptual contributions. These are a novel set theoretical concept for information supply and demand, a general concept of spatial geometries for transacting supplied and demanded information in space, and a concept for generalized spatio-temporal reasoning about information supply and demand relations. Combined with the method, all three concepts allow detection and measurement of misfits under consideration of interferences. The thesis gives insight into the development of the method-supporting software artifact ShiATSu. For evaluation, ShiATSu is successfully applied within three hypothesis tests, which try to proof, that 1) differences between work spaces are representable and measurable with the described method and concepts, 2) work space layout has an effect on Situation Awareness and 3) collaborative processes have an effect on Situation Awareness.



## Zusammenfassung

Neben Umwelteinflüssen und technischen Problemen sind menschliche Fehler in bis zu 85 % der Fälle der Hauptgrund für Unfälle im Seeverkehr. Reviews von Unfallberichten zeigen, dass mangelndes Situationsbewusstsein (mit 71 %) die Hauptursache für diese Fehler ist. In den meisten Fällen kann die menschliche Unzulänglichkeit auf zwei Tatsachen zurückgeführt werden: Entweder waren zu viele oder zu wenige Informationen vorhanden. Grund dafür können heutige Schiffsbrückendesignprozesse sein, welche die Zusammengehörigkeit von räumlicher Informationsverteilung und zeitlichen Aspekten der kollaborativen Brückenarbeiten vernachlässigen. In dieser Arbeit werden beide Aspekte gemeinsam adressiert: Mit der entwickelten computer-gestützten Methode kann die raum-zeitliche Eignung von Informationsangebot und -nachfrage in nautischen Situationen bereits zur Designzeit der Schiffsbrücke bewertet werden. Die systemische Grundlage bildet dabei die Theorie des verteilten Situationsbewusstseins (Distributed Situation Awareness). Die Methode besteht aus drei Schritten: Modellierung eines integrierten räumlichen und kollaborativen Modells, simulierte Ausführung der Arbeitsprozesse in der Arbeitsumgebung sowie der qualitativen und quantitativen Analyse eines Simulationslaufes, die es erlaubt Insuffizienzen zwischen Angebot und Nachfrage zu detektieren. Dieser methodische Beitrag wird von drei konzeptuellen Beiträgen begleitet. Es handelt sich dabei um ein neues mengentheoretisches Konzept über Informationsangebot und -nachfrage, ein generelles Konzept von räumlichen Geometrien zur Transaktionierbarkeit von Informationsangebot und -nachfrage in Räumen, und einem Konzept zum generalisierten raum-zeitlichen Schlussfolgern über Informationsangebots- und Informationsnachfragerelationen. Die drei Konzepte ermöglichen es gemeinsam mit der Methode auch unter Einbeziehung von Interferenzen (zum Beispiel Störungen durch Veränderungen im Raum) Insuffizienzen im Prozessablauf zu aufzudecken und zu messen. Weiterhin gibt die Arbeit einen Einblick in die Entwicklung des Softwareartefakts ShiATSu, welches die Methode unterstützt. ShiATSu wird erfolgreich anhand von drei Hypothesentests evaluiert, anhand welcher bewiesen werden soll, dass 1) Unterschiede zwischen Arbeitsumgebungen mit der Methode und den Konzepten der Arbeit abbildbar und messbar sind, dass 2) Arbeitsumgebungen einen Effekt auf das Situationsbewusstsein haben, und dass 3) kollaborative Arbeitsprozesse einen Effekt auf das Situationsbewusstsein haben.



## Acknowledgement

“Anyone who is unable to divide, is also unable to multiply”, is a saying I picked up during a meeting at the Maritime Competence Centre (MARIKO) at the beginning of my doctoral research in 2013. Since then, plenty people divided and multiplied with me, of course exceeding the pure mathematical definition. With these lines I would like to show my deep appreciation for those who shared their knowledge, provided their openness, gave sincere feedback and constructively supported me during production of the artefacts presented within this thesis.

First of all, I would like to emphasize my strong gratitude to Prof. Dr.-Ing. Axel Hahn for his excellent advisory, which I always perceived as a supportive chance to extend my horizons. He triggered my active interest for process analysis (already during my master studies) and socio-technical systems modelling and analysis in the maritime domain. The latter being a framework embedding this thesis topic. Particularly, I appreciate the thought-out reflectiveness and positively received candor which Axel fostered during our discussions with regards to my concepts, methods and methodology. I am also very grateful to Prof. Thomas Porathe (NTNU), who brought in his experience in maritime human factors and (interaction) design of maritime information systems. He has been working with e-Navigation since 2006 and has reviewed this thesis as an external reviewer. During my work at the OFFIS - Institute for Information Technology Prof. Dr. techn. Susanne Boll-Westermann supported me with her expertise on individual human factors approaches, which I am thankful for. Further, I would like to give thanks to Prof. Dr.-Ing. habil. Jorge Marx Gómez and Dr.-Ing. Florian Fortmann for their contribution as members of my disputation committee.

At OFFIS I worked within the European project CASCADE, where I received the freedom to organize and pursue this research. I thank Dr. Cilli Sobiech for these freedoms, the discussions on- and off-topic and, together with Dr. Andreas Lüdtkke, for the integration of my contribution with the overall CASCADE ship bridge design methodology. Within the project, I always perceived the industrial and scientific partners from BMT Group, University of Cardiff, Marimatech, Mastermind Shipmanagement, Raytheon Anschütz and Symbio as backing, open and constructional, which may not be taken for granted. Besides the overall magnificent collaboration, I would like to express my special lift out scientific recognition to: Denis Javaux, who shared his impressive knowledge in control room design with me through intensive discussions at the outer bounds of the current state of the art, and Paul Allen, for his inspiring creativity and collaboration in study setup and execution throughout the whole project. For

familiarization with the maritime domain I conducted intense in-situ observations on-board ships and in simulators. Therefore, I appreciate the support received from several valuable enablers at Mastermind Ship Management, Hapag-Lloyd, Mols-Linien, Elbe Pilots and Jade HS Elsfleth.

My cordial thanks goes to the group members of Cooperative Mobile Systems and Human-Centered Design at OFFIS and the Systems Analysis and Optimization Group at the University of Oldenburg. They supported me with valuable subject-specific feedback and good laughter. I would like to specially give thanks to Dr.-Ing. Jan Pinkowski for his good advice and to my research assistants Stefan Langhammer, Kevin Möhlmann and Julius Möller for their support in software implementation.

Last but not least, I would like to express my deepest gratitude to my friends and families Denker, Ahrens, Buss, Jantzen and Günther for the warm-hearted backing over the whole process. I am especially obliged to thank my good friends Tammo and Katharina for the causation of the DT2000 and Steffen for the PaletteCAD license. You all have kept me enthusiastic through your lovable characters, motivating words and shared wisdoms.

Finally, my biggest gratitude goes to my significant other - Lisa, who supported me tenderly, independent of any tertiary circumstances, in every possible sense with her love. Thank you!

Christian Denker

Oldenburg, 14<sup>th</sup> June 2016



## Contents

Abstract .....	I
Zusammenfassung .....	III
Acknowledgement .....	V
Contents .....	VII
List of Figures .....	IX
1 Introduction .....	1
1.1 Motivation .....	2
1.2 Challenges .....	3
1.3 Objectives .....	6
1.4 Contributions .....	9
1.5 Chapter Overview .....	10
2 Related Work .....	13
2.1 The Human-Centered Design Process (ISO 9241-210) .....	13
2.1.1 Activity 1 – Understand and Specify the Context of Use .....	15
2.1.2 Activity 2 – Specifying the User Requirements .....	15
2.1.3 Activity 3 – Producing Design Solutions .....	15
2.1.4 Activity 4 – Evaluating the Design .....	17
2.2 Information Distribution in Nowadays Bridge System Design .....	18
2.2.1 Function-oriented Layout of Workstations .....	18
2.2.2 Task-oriented Layout for Integrated Navigational Systems (INS) .....	19
2.2.3 Displays in Field of View .....	20
2.2.4 Access to Controls .....	20
2.2.5 Audible Alarms .....	21
2.2.6 Working Environment .....	21
2.2.7 Further Standards .....	22
2.3 Distributed Situation Awareness .....	22
2.3.1 Individual Situation Awareness .....	22
2.3.2 Distributed Situation Awareness .....	25
2.4 Analyzing Distributed Situation Awareness .....	28
2.4.1 Event Analysis of Systemic Teamwork .....	28
2.4.2 Workload, Error, Situation Awareness, Timing and Teamwork .....	36
2.5 Objective Coverage Summary .....	40
3 Requirements to a Solution .....	43
3.1 RG1 – Representation of Spatio-Temporal Information Supply and Demand of Bridge and Crew .....	43
3.2 RG2 – Execution of Crew Work on the Ship Bridge .....	45
3.3 RG3 – Provisioning of Measurements .....	46
4 Assessment of Spatio-Temporal Information Supply and Demand Fitness .....	49
4.1 Use Case: Course Change in Open Waters .....	49
4.2 The Set Theoretical Concept of Information Supply and Demand .....	51
4.3 Sensomotoric Geometries for Transacting Information Supply and Demand .....	54
4.4 Generalized Spatio-Temporal Reasoning Model for Information Supply and Demand .....	58
4.4.1 Spatio-Temporal States .....	59
4.4.2 Formalization of Life and Motion Configurations .....	61

## Contents

---

4.5	Modelling - Creating an Integrated Model for Process Execution .....	62
4.5.1	Integrated Model Elicitation .....	63
4.5.2	Model Execution Planning & Verification .....	71
4.6	Simulation - Process Execution in Work Spaces .....	77
4.6.1	Simulation Setup .....	78
4.6.2	Environment Verification .....	82
4.6.3	Simulation Execution.....	85
4.7	Analysis - Measure Provisioning & Assessment .....	87
4.7.1	Computational Analytics .....	88
4.7.2	Assessment.....	91
4.8	Conclusion .....	93
5	Implementation of the ShiATSu Prototype .....	97
5.1	Architecture Design .....	97
5.1.1	LayoutEditor .....	98
5.1.2	EMod .....	100
5.1.3	IMod .....	100
5.1.4	Mophisto .....	101
5.1.5	StatechartEditor .....	102
5.1.6	ModellingTools.....	102
5.1.7	SimulationTools.....	103
5.1.8	AnalysisTools.....	104
5.2	Implementation.....	105
5.2.1	LayoutEditor's Implementation .....	106
5.2.2	EMod, IMod, Mophisto and StatechartEditor Implementation.....	106
5.2.3	ModellingTools Implementation.....	107
5.2.4	SimulationTools Implementation.....	108
5.2.5	AnalysisTools Implementation .....	110
5.3	Conclusion .....	111
6	Evaluation.....	113
6.1	Differences between Work Spaces are representable and measurable.....	113
6.1.1	Study Design.....	113
6.1.2	Method Execution .....	118
6.1.3	Results .....	125
6.2	Work Space Layout has an Effect on Situation Awareness .....	125
6.2.1	Questionnaire.....	126
6.2.2	Response Analysis .....	127
6.2.3	Results .....	129
6.3	Collaborative Process has an Effect on Situation Awareness.....	130
6.3.1	Study Design.....	131
6.3.2	Method Execution.....	136
6.3.3	Questionnaire Feedback .....	144
6.3.4	Results .....	146
6.4	Conclusion & Objectives' Coverage.....	147
7	Summary and Outlook .....	149
7.1	Summary.....	149
7.2	Outlook.....	152
8	References.....	155
A	Appendix .....	163

## List of Figures

Figure 1: Ships lost per month during the 2011-2013 reporting period - A total of 145 ships with an average of four ships lost per month. Source: (EMSA 2014) .....	1
Figure 2: Distribution of Situation Awareness errors amongst the levels 1 - 3. Source: (Grech et al. 2002) .....	2
Figure 3: The challenge: Adjustability of crew organization and bridge information distribution during the planning, design, construction and operation phase of a ship life cycle .....	3
Figure 4: Chapter Overview .....	11
Figure 5: Interdependence of human-centered design activities. Source: (ISO 9241-210 2011) .....	14
Figure 6: Example of function areas. Source: (IMO 1999) .....	19
Figure 7: Horizontal Field of View. Source: (IMO 1999) .....	20
Figure 8: Classification of reaching areas from (DNVGL 2014, p.38) .....	21
Figure 9: Passageway limits between workstations and deckhead height from (DNVGL 2014) .....	22
Figure 10: SA Example - Overtaking in a Traffic Separation Scheme (TSS) .....	23
Figure 11: Endsley's Three Level Model of Situation Awareness in the human decision-making cycle. Source: (Endsley 1995a) .....	24
Figure 12: Neisser's Perceptual Cycle (Neisser 1976) .....	25
Figure 13: Shared Situation Awareness (left) vs. Compatible Situation Awareness (right) .....	26
Figure 14: Model of Distributed Situation Awareness in Complex Collaborative Systems (Salmon et al. 2009, p.184) .....	28
Figure 15: Six system characteristics of EAST according to (Wilson 2014) from (Stanton 2014) .....	29
Figure 16: Network of networks approach. (Stanton 2014) .....	31
Figure 17: Exemplary Task Network for anchoring on a reede .....	32
Figure 18: Exemplary Social Network for anchoring on a reede .....	33
Figure 19: Exemplary Information Network for anchoring on a reede .....	33
Figure 20: Exemplary Social Network Analysis for the reede anchoring scenario .....	35
Figure 21: Combined Social-Task-Information Network .....	36
Figure 22: Sequence Diagram for anchoring on a reede .....	37
Figure 23: Use Case Diagram for anchoring on a reede .....	38
Figure 24: Exemplary Text Analysis by WESTT with resulting Propositional Network .....	38
Figure 25: Exemplary Composite Diagram .....	39
Figure 26: Excerpt of resulting Classes .....	40
Figure 27: Course change on a bulk carrier - the Next Course information element from the ECDIS is demanded by the Navigator, who supplies it to the Helmsman, who steers the rudder. Meanwhile, a Lookout is monitoring the sea for potential dangers. ....	50
Figure 28: The information gap model describes the relation between information supply and demand. Information supply and demand are two sets mapping to information elements. $IG^+$ represents oversupply and $IG^-$ the undersupply of information elements. In the ideal situation information supply and demand sets are equal ...	52
Figure 29: Sensomotoric Geometries for Transacting Information Supply and Demand between a Human and a Machine Agent over Vision on a Ship Bridge .....	55
Figure 30: Decision tree and notation of spatio-temporal states for Life and Motion Configurations for existence and transactability adopted from (Hallot & Billen 2008a) .....	60
Figure 31: Formalization of a Spatio-Temporal History into the Life and Motion Configuration variant. Cubes indicate sensomotoric geometries ready for transaction of information element A (green) and B (blue) in a 3D temporal space. The LMC representation shows the evolution of spatio-temporal states over time. In $t_4$ information elements are transactable .....	61

## List of Figures

---

Figure 32: Step 1 - Modelling - Creating an Integrated Model for Process Execution.....	63
Figure 33: Technical drawing of Use Case ship's bridge layout .....	64
Figure 34: The Integrated Model Triangle consists of an Information Model, a Collaborative Process Model and a Spatial Model. Here, instances of these models are depicted for a nautical scenario. ....	65
Figure 35: Step 2 - Simulation - Process Execution in Work Spaces.....	78
Figure 36: Visualization of the Use Case's Simulation Environment with its hull (1), human and machine agent body geometries (2), sensomotoric geometries (3) and artifacts (4).....	80
Figure 37: Visualization of two scene graphs scheduled at $t_0$ and $t_3$ : Changes were applied to the chair's body geometry and display's sensomotoric geometry.....	81
Figure 38: Intra-Scene comparison of occupied areas: In $t_3$ a required pathway to the ECDIS is obstructed – the amount of occupied areas is not equal ( $5 \neq 4$ ) .....	84
Figure 39: Algorithm for Resource Management Execution in Pseudocode .....	86
Figure 40: Step 3 - Analysis - Measure Provisioning & Assessment.....	87
Figure 41: Table of spatio-temporal states with interpretation in set theory and required actions for Human-Machine Interaction. There exist 14 possible and 6 impossible states.....	89
Figure 42: Separation of reporting into high and low level cost aggregation for two agents ....	90
Figure 43: Multiple Collaborative Process Models are used for comparative assessment of two Spatial Models .....	93
Figure 44: Component Diagram of ShiATSu .....	98
Figure 45: Class Diagram of the LayoutEditor and interconnections to ShiATSu components ..	99
Figure 46: Class Diagram of a HAGGIS data model subset provided via EMod .....	100
Figure 47: Class Diagram of IMod's data model.....	101
Figure 48: Class Diagram of relevant Mophisto classes with relation to IMod.....	102
Figure 49: Class Diagram of StatechartEditor's data model.....	102
Figure 50: Class Diagram of ModellingTools .....	103
Figure 51: Class Diagram of SimulationTools .....	104
Figure 52: Class Diagram of AnalysisTools .....	104
Figure 53: ShiATSu integrates EMod, IMod and Mophisto with means of the LayoutEditor. The LayoutEditor's content of the represents EMod 3D models in 2D top view, these models can be human agents, machine agents, artifacts or hull. Machine agents reference multiple information elements from IMod. Human agents reference an actor in a Mophisto Collaborative Process Model. Tasks, such as 'steer', are referencing information elements as supply or demand as well. ....	105
Figure 54: EuGENia model-driven definition of IMod .....	107
Figure 55: Difference between two implemented Work Planners .....	108
Figure 56: Pop-up dialog displaying results of the WorkPlanVerifier .....	108
Figure 57: Intra-Scene Graph Verification with two alternative test specimens.....	109
Figure 58: Output of ReportCreator - high level and low level report.....	110
Figure 59: 3DViewer showing the traversed path (red) of the Navigator (compare Figure 53) towards the ECDIS (right, with sensomotoric geometry) .....	111
Figure 60: Conditions of the simulator experiment .....	114
Figure 61: Simulator Suite during simulation with Master (left) and Pilot (right) during start of passage in Kiel harbour. Video cameras capture their interactions and display content.....	114
Figure 62: A map of the simulation scenario with traffic setup in Kiel harbour .....	115
Figure 63: Camera placement in the simulator suite .....	117
Figure 64: Shared Display mockup – an ECDIS with a slide annotated with white-board pens (blue) and an exchanged route (red).....	118
Figure 65: Excerpt of the Information Model in IMod .....	119

Figure 66: A CPM for encountering with jetty after keeping clear of Stena Germanica with annotated commentaries from video footage .....	120
Figure 67: 3D model with sensomotoric geometries of the simulator. The model is used as input to the LayoutEditor .....	121
Figure 68: Abstract visualization of the simulator’s ship bridge in the LayoutEditor with referenced information elements of left ECDIS in condition 1 .....	122
Figure 69: Condition 1 vs. Condition 2 of encounter with jetty.....	122
Figure 70: Excerpt from the occupancy grid generated during runtime verification .....	123
Figure 71: Screenshot form 3DViewer visualizing the simulator bridge with sensomotoric geometries and human agents’ paths.....	123
Figure 72: Excerpt of LMCs in Condition 1 .....	124
Figure 73: High level comparison of both conditions .....	125
Figure 74: Averages of subjective performance measurements of Captains, Pilots (left), and Instructor (right) as 7-point polar diagrams with data table.....	128
Figure 75: Averages of subjective comparative judgement for Feature 1 (left, shared routes) and Feature 2 (right, changing waypoints) with data table .....	129
Figure 76: Simulator suite with the CASCADe ship bridge providing both baseline and CASCADe Condition .....	132
Figure 77: Cameras setup in the upper left, lower right and ceiling of the simulator suite .....	132
Figure 78: Excerpt from the Cognitive Walkthrough guide, with route exchange feature relevant steps 3 and 4 .....	134
Figure 79: Introduction of the route exchange feature to participants at the central console	134
Figure 80: Questionnaire excerpt: Querying comparative feedback for each step.....	135
Figure 81: Questionnaire excerpt: Querying feedback on PPU tools .....	136
Figure 82: Route exchange feature extensions to the Information Model in IMod.....	137
Figure 83: CPMs of baseline (left) and CASCADe (right) Condition .....	138
Figure 84: 3D model with sensomotoric vision geometries of the simulator and PPU (right) ..	139
Figure 85: LayoutEditor model created from 3D model on Figure 84 .....	139
Figure 86: ECDIS and PPU - InformationStates for baseline and CASCADe Condition.....	140
Figure 87: Baseline Condition vs. CASCADe Condition for exchanging a route .....	140
Figure 88: Excerpt of the occupancy grid generated during runtime verification.....	141
Figure 89: Screenshot form 3DViewer visualizing the ship bridge with human agents’ paths (baseline condition) .....	141
Figure 90: LMC with change of an Information State .....	142
Figure 91: High level comparison baseline and CASCADe Condition.....	143
Figure 92: Low level reports: CASCADe Condition requires less SA Transactions .....	143
Figure 93: Low level report with IG <sup>+</sup> , IG <sup>-</sup> and RMS (Denker et al. 2014) .....	144
Figure 94: Mean values for comparative feedback of steps 1 to 5.....	145
Figure 95: Comparative feedback on route exchange .....	146



## 1 Introduction

Shipping is an essential transport modality for today's society that is often not physically visible to most humans in their every day's life. Thereby "about 90% of world trading is carried out by the shipping industry" (Chauvin et al. 2013) and shipbuilders are constantly enlarging their new builds' capacities for cargo (Tran & Haasis 2015) and passengers<sup>1</sup>. While ship sizes are increasing, the potential risk to human life and the fatality of impacts on the environment through accidents is ascending as well. In the period from 2011 to 2013 a total of 4015 ship casualties have been reported to the European Marine Casualty Information Platform (EMCIP) of the European Maritime Safety Agency (EMSA) (EMSA 2014). These reported casualties include the categories capsizing/listing, collisions, contacts, damages to ship or equipment, fire/explosion, flooding/foundering, grounding/stranding, hull failures and the loss of control of overall 4017 ships (with an overall casualty involvement of 6685 ships). The EMCIP numbers indicate an increase in casualties over the reported period and this is also in accordance with international figures of the International Maritime Organization (IMO), which indicate an increase<sup>2</sup> of casualties from 2006 to 2010 as well (IMO 2012).

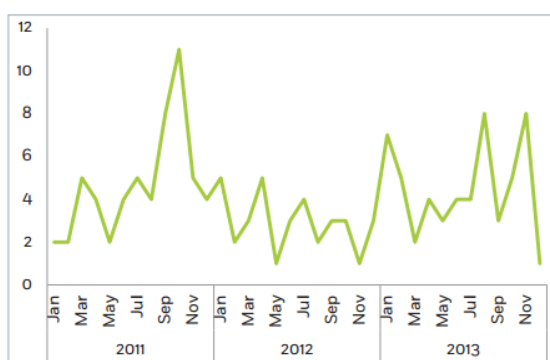

**Figure 1: Ships lost per month during the 2011-2013 reporting period - A total of 145 ships with an average of four ships lost per month. Source: (EMSA 2014)**

Since these numbers sound rather not promising for our society, it's sensible to identify and try to eliminate the root causes of the casualties: Studies indicate that the root cause, besides environmental influences or technical faults, is in up to 85% the human error during shipping (Baker & McCafferty 2005). Due to that fact, it's worth to reason further for the origins of the human error.

<sup>1</sup> <http://www.cruisemarketwatch.com/growth/>, visited 20.01.2016

<sup>2</sup> E.g. the ship loss rate of the world fleet raised from 1.3 in 2006 to 1.7 in 2010

## 1.1 Motivation

In (Hetherington et al. 2006) and (Grech et al. 2002) detailed insight into human error composition on ships is given - all based on accident data from international accident investigation branches. According to (Grech et al. 2002) 71% of 177 examined accidents were caused through situation awareness (SA) errors. By assuming that the law of large numbers is applicable to the statistics, this indicates that SA errors can account for up to 60% of all European shipping casualties. So, what is SA at all?

The concept of SA is well defined multiple times (e.g. Endsley 1995a; Smith & Hancock 1995; Sarter & Woods 1991; Adams et al. 1995; Hourizi & Johnson 2003; Taylor 1990) in literature and was mostly minted by Human Factors research in aviation. The most popular definition is given by Endsley (Endsley 1995b). She defines SA as a state in the individual human decision-making process. SA is built out of the status of the elements in the environment and is the basis for making decisions. SA is composed of three levels including the perception (level 1), comprehension (level 2) and projection (level 3) of information.

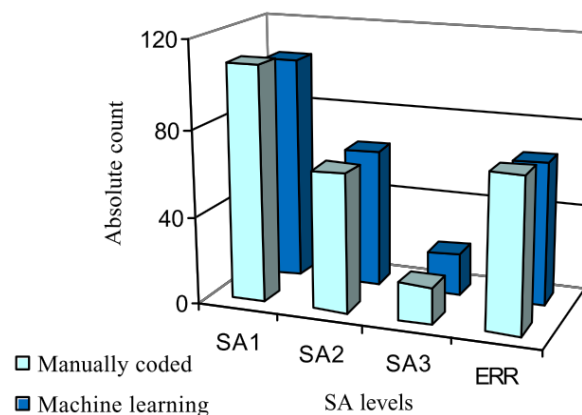

**Figure 2: Distribution of Situation Awareness errors amongst the levels 1 - 3. Source: (Grech et al. 2002)**

Accident report reviews use these SA levels to distribute accident causes amongst them: 60 - 77% of SA induced errors are errors on level 1, besides 20 - 30% on level 2, and 3 - 9% on level 3 (Grech et al. 2002; Bolstad et al. 2002). Figure 2 illustrates a distribution by Grech et al. Furthermore, errors on level 1 can cascade to errors on level 2 and level 3 (M. R. Endsley, 1995). This implies that the elimination of level 1 error could lead to a significant reduction of accidents already. The level 1 error can have various causes, which cannot be strictly attributed to humans. This can be reasoned from the SA error taxonomy that has its origin in



aviation, as well. The taxonomy states five causes for level 1 error (Jones & Endsley 1996): **‘data is not available’, ‘data is hard to discriminate or detect’, ‘monitoring or observation of data failed’, ‘misperception of data occurred’** as well as **‘memory loss’**.

By analyzing these cause categories it gets obvious that machines and the system of humans and machines can be defined as error sources for the SA error as well. Further, it’s deducible from the categories that the common cause is that there is either information not available or there is too much information available to the individual.

## 1.2 Challenges

On a ship bridge this means, that the crew has problems to satisfy their information demand and supply during execution of a task in a navigation situation. On the other hand **ship bridges** are static working environments nowadays, which **do not sufficiently supply and demand the required information** (Ross 2009, p.96ff.). The obvious reasons for this Information Gap (IG), created through the misfit between information supply and demand, are the **spatial and temporal aspects** of crew work on the ship bridge. The spatial aspect comprises, that **information is distributed** across different locations. This can be based on the size of a bridge: In comparison to other means of transportation such as airplanes, trains and cars, the bridges of merchant ships are mostly relatively huge work places. Positioning of equipment and workstations influence crew’s work space (e.g. through walking distances) and thus can highly contribute to delays in access to these (temporal aspect). Of course adverse weather conditions, such as heavy swell and strong winds, can further amplify these delays.

	Planning phase	Design phase	Construction phase	Operational phase
Adjustment of crew work organization	limited	limited	limited	possible
Adjustment of bridge information distribution	possible	possible	possible	limited

**Figure 3: The challenge: Adjustability of crew organization and bridge information distribution during the planning, design, construction and operation phase of a ship life cycle**

To encounter the emergence of Information Gaps, two main classes of adjustments can be applied during the ship bridge's life cycle (Papanikolaou 2009, pp.181–182). These are the **adjustment of crew work organization** and the **adjustment of bridge information distribution** which are depicted with the life cycle phases in the matrix in Figure 3.

Definition 1: **Adjustment of crew work organization** is an alteration of the content or temporal order of a task in a process or the (re)assignment of a task to a crew member.

Definition 2: **Adjustment of bridge information distribution** is an alteration of the spatial position, the existence, or the presence of information in the ship bridge space.

Both classes are derived from literature (Baker & McCafferty 2005; Hetherington et al. 2006; Antão & Guedes Soares 2006) where crew work organization and bridge information distribution are mentioned combined as Bridge Resource Management (BRM) or separately with the terms of f.i. “bridge layout”, “teamwork” or “communication”.

In the following, the challenges associated with the adjustment classes are described with more detail to their applicability to the two life cycle phases **planning, design and construction** and **operation**:

- **On the adjustment of crew work organization during planning, design and construction:** During nowadays planning, design and construction of a ship bridge information is statically positioned on consoles and equipment. This is done by naval architects following standards, guidelines and fulfilling legislative requirements. Examples of these are IMO Standards on Maritime Safety (MSC) and on Safety of Navigation (NAV), the International Convention for the Safety of Life at Sea (SOLAS) from United Nations (UN) and rules of ship classification societies such as “Rules for Classification and Construction” from DNVGL (Germanischer Lloyd 2012). Often, these regulations have a strong technical focus and **neglect the operational, task-driven and situation-dependent, requirements** of the crew: The standards are defined for work of a single crew member on one workstation, but the work processes to be accomplished by the whole crew are not considered. Hence, engineers do not integrate crew work organization and their adjustment into the pre-operation life cycle phases of the bridge by default. Notwithstanding the fact that it would be theoretically possible to integrate it.

- **On the adjustment of bridge information distribution during planning, design and construction:** Even if the standards consider the aspects bridge layout, consoles and user interfaces, they further foster **vague definitions, static work environments and task work** of solely one crew member. An example for a vague definition is the latest IMO MSC.252(83) standard for Integrated Navigational Systems (INS). There it's stated that "The INS supports mode and situation awareness" (IMO 2007), but it's not noted how a manufacturer can achieve compliance to that requirement. Further the standard references the guideline IMO MSC/Circ.982 on ergonomic criteria for bridge equipment and layout (IMO 2000). In its second appendix proposed equipment configurations for workstations are listed, which imply continuous presentation of **all information at once**. This does not match with the INS standard's requirement for multifunctional displays. A **multifunctional display** is a "single visual display unit that can present, either simultaneously or through a series of selectable pages, information from more than a single function of an INS" (IMO 2007). This means that presented information can be toggled to be present or not. Engineers struggle in solving that ambiguity since both requirements can only be fulfilled by adding additional equipment. This could lead to an potential information overflow for the crew (Endsley & Jones 2011, p.4). Further, the standards are defined for work of a single crew member on one workstation. But in fact the nature of bridge work is **teamwork**, as distinction to task work (Salas et al. 2008), and this is not considered during the design of a bridge information distribution at the moment.
- **On the adjustment of crew work organization during operation:** Adjustments to the crew's work organization during operation are commonplace, since merchant ship's crew rotation requires another crew to take over typically every four months. Depending on the ship and its bridge, the crew adjusts by altering personnel or work shifts. This ought to be a solution, but can cause **additional cost, require additional communication between the crew or may reduce periods of rest**. The latter two may introduce further risks, e.g. failures in communication and reduction of work force.
- **On the adjustment of bridge information distribution during operation:** The adjustments of the bridge during operation cause **costs** (Page 2012) as well and are often **not easy to apply** - especially while sailing. On nowadays ship bridges equipment from various manufactures is often ad-hoc integrated during the build and installed on consoles supplying and demanding **information on fixed positions**. Mostly displayed

continuously in every shipping situation. This does not fit the seafarers' **situation-dependent** and **task-based** information supply and demand (Motz et al. 2011). E.g. information about the anchor winch status may only be demanded when willing to anchor the ship. During bridge work the crew has to find, sort, process and integrate information (Endsley & Jones 2011, p.4). Too much information may lead to an **information overload** (Bolstad et al. 2006) and supply of less than crew demanded information may impede the work. Hence it's sensible to already consider these adjustments during the design of a ship bridge.

The outline of the described challenges is the following: Spatio-temporal aspects of information supply and demand are important but insufficiently considered. During operation adjustments to the bridge information distribution are not feasible and adjustments of crew work organization are not considered in planning, design and construction of a ship bridge today.

### 1.3 Objectives

This thesis addresses the challenges (chapter 1.1) by provisioning a method, which allows assessing the spatio-temporal fitness of information supply and demand on a ship bridge at design time, taking the crew work organization and the bridge information distribution into account. Meanwhile, the scientific focus of this thesis is to give an answer to the

***Research Question: How to assess ship bridges for crew's information supply and demand in navigational situations during design time?***

In the following the question is disassembled into two sub-questions. Objectives to answers to these sub-questions are defined by derivation from the challenges.

***Sub-Question 1: Which concepts/methods/techniques are needed to represent spatio-temporal information supply and demand of bridge and crew?***

Objective 1 – **Integration of crew work organization and bridge information distribution during design time** (Systems perspective for ship bridge assessment.). A concept, method or technique that answers the question should provide an integrated view on spatio-temporal issues emerging in and in-between the bridge information distribution and crew work organization. If both are considered within a systems perspective, a holistic view on the fitness and misfits between information supply and demand can be given. This allows deciding on

causes of misfits, which adjustment class to apply and to foresee what an adjustment would imply for the overall system.

**Objective 2 – Consideration of sequential task and collaborative teamwork.** The crew work organization on the ship bridge constitutes of both, task and team work. As mentioned, during design team work and the order of task execution is neglected. A description of the crew work organization shall consider the sequential order of crew work and the team work between two or more crew members.

**Objective 3 – Consideration of dynamic information presentation.** Bridge information distribution is defined with fixed information or is constituted of multifunctional displays, whose information can be dynamically toggled to be present or not. On future bridges it may even be conceivable that bridge information locations can be swapped arbitrarily between multiple locations on the bridge. This requires the concepts, methods and techniques to represent spatial locations and dynamic spacial changes in the presence of information. Dynamic changes in both, information supply and information demand of the bridge, need to be considered. Changes in the presence can be enforced by the crew or a tertiary system during operation, e.g. through a sensor system.

**Objective 4 – Adjustment of crew work organization and bridge information distribution.** Both, crew work organization and bridge information distribution are sub-systems of a ship's bridge. During design time both systems shall be adjustable separately from each other. This means, the concepts, methods and techniques shall provide structures that describe the sub-systems generally decoupled, while having a common base, which allows ad-hoc coupling. The common base is the information which are supplied and demanded during operation.

**Objective 5 – Reusability of crew work organization and bridge information distribution.** During design the ship bridges' sub-systems are created, coupled with each other and adjusted. Since this is an effort causing enterprise, the concepts, methods and techniques for representation of information supply and demand shall allow for reuse of created sub-system descriptions. E.g. a ship bridge manufacturer shall be enabled to facilitate an existing description of crew work organization from a shipping line in an assessment of a bridge information distribution description. Further, structure descriptions (e.g. equipment, tasks, communications) of the bridge information distribution and crew work organization shall be both, reusable and not foster repetitive description.

**Objective 6 – Formalization of bridge information distribution and crew work organization.** Natural language descriptions are typically used to describe the sub-systems in standards, guidelines, best practices as well as standards operating procedures and product data sheets. These descriptions are (often) not machine-processable, since they provide a broad range of interpretations due to unbound syntax and semantics. To enable for machine-processability, unambiguous interpretability and reusability the assessment shall be formalized. The formalization comprises both the representation of bridge information distribution and crew work organization, and the methods and metrics (sub-question 2) with their relation of information supply and demand.

***Sub-Question 2: Which methods and metrics enable measurement of the Information Gap between information supply and demand for spatio-temporal dimensions?***

**Objective 7 – Measurement of misfits between information supply and demand.** On an ideal ship bridge all information is directly perceivable by the crew when they are needed during work. Through the spatial distribution of information and the temporal duration to make information perceivable, misfits between information supply and demand may arise. The methods and metrics shall allow detecting these misfits and qualify their impact with metrics. Results should allow for identification of problems within both crew work organization and bridge information distribution.

**Objective 8 – Traceability of misfits.** To encounter misfits it is necessary to find their causes. These can be implied by crew work organization, the bridge information distribution or both. The methods shall allow backtracking to sources of a misfit. This means that positions of equipment and crew, states of equipment and the progress of the crews' work processes can be inspected at design time for a specific point in time during operation.

**Objective 9 – Comparability of measurements.** The assessment of a crew work organization-bridge information distribution-combination consists of a set of measurements. This set shall be comparable to other combinations, which are generated by altering either the crew work organization or the bridge information distribution. The comparability shall be enabled on the level of a set of measures and on single-measurement levels.

## 1.4 Contributions

This thesis is contributing a solution for the challenges (chapter 1.2) by fulfilling the objectives (chapter 1.3) with the development of a computer-supported method for spatio-temporal information supply and demand fitness assessment on nautical ship bridges.

The method comprises a 3-step iterative procedure which integrates with the assessment tool ShiATSu (Situation Awareness Tool Suite), which is the software artifact of this thesis. The 3-step method builds upon three basic concepts. These are (1) a set theoretical concept of information supply and demand derived from concepts in the field of SA and business science, (2) a concept on spatial transactability of information supply and demand, which bases on a solid mathematical foundation, and (3) a concept for reasoning about information supply and demand in space and time, which adopts from a spatio-temporal calculus. All three concepts form the joint core of the 3-step method, which guides its user through modelling, simulation and analysis of information supply and demand.

The overall scientific contribution of this thesis can be summarized as follows: “Development of a method and concepts for semi-automated spatio-temporal assessment of information supply and demand based on ship bridge layout models and collaborative nautical navigation processes”. In more detail this contribution is described with the following claims, which are met within this thesis:

1. The method provides a systems-oriented assessment approach that is integrable into current ship bridge design.
2. Concepts and method form a spatio-temporal assessment method that enables comparable measurements of distributed situation awareness based on ship bridge layouts and collaborative nautical processes.
3. Concept and method are supportable through software applications.

## 1.5 Chapter Overview

This thesis is structured into five main chapters, which elaborate the contribution in-between the introduction and the conclusion chapters. The presented research is adopting the design science research process (DSRP) for producing and presenting information systems research (Peppers et al. 2006). The problem-centered DSRP approach is followed, which begins with *problem identification & motivation* (chapter 1). Consecutively, the *objectives of a solution* (chapter 1) are defined. The adopted DSRP's aim is to achieve coverage of the objectives through *design and development*. *Design and development* includes the review of related work (chapter 2), which provides a conceptual foundation. Within the related work, requirements towards an improved solution are identified (chapter 3), whose fulfillment covers the objectives completely. Based on this, the *design and development* process produces a new method and extends existing concepts that fulfill the requirements (chapter 4). Further an artifact is produced (chapter 5), allowing executing the method and implementing the concepts. The DSRP foresees *demonstration* of the artifact as a successive step to *design and development*. However, within this thesis the method and concepts are demonstrated with a use case (aligned in chapter 4). Next, Peppers et al. described the *evaluation* of method and concepts to be done by e.g. observing the artifact's success, measuring its effectiveness or efficiency, or collecting user feedback. In this thesis, the artifact's success is examined through the application to research on three hypotheses (chapter 6).

In chapter 2 the related work is presented. This includes the human-centered design process, according to ISO 9241-210, an overview of nowadays information distribution during the design of ship bridges, the Distributed Situation Awareness theory, methods to analyze the Distributed Situation Awareness as well as a summary of the objective's coverage. Identified gaps in the objective coverage are described as requirements to a solution in chapter 3. Three requirement groups are aggregating requirements on representation of spatio-temporal information supply and demand, on execution of crew work on ship bridges, and on provisioning of measurements.

Chapter 4 describes the assessment method and concepts. After the simple use case on changing the course in open waters, three concepts are introduced, which enable the method. Namely the concepts are the set theory of information supply and demand, the concept of sensomotoric geometries of spatial SA Transaction and the generalized spatio-temporal



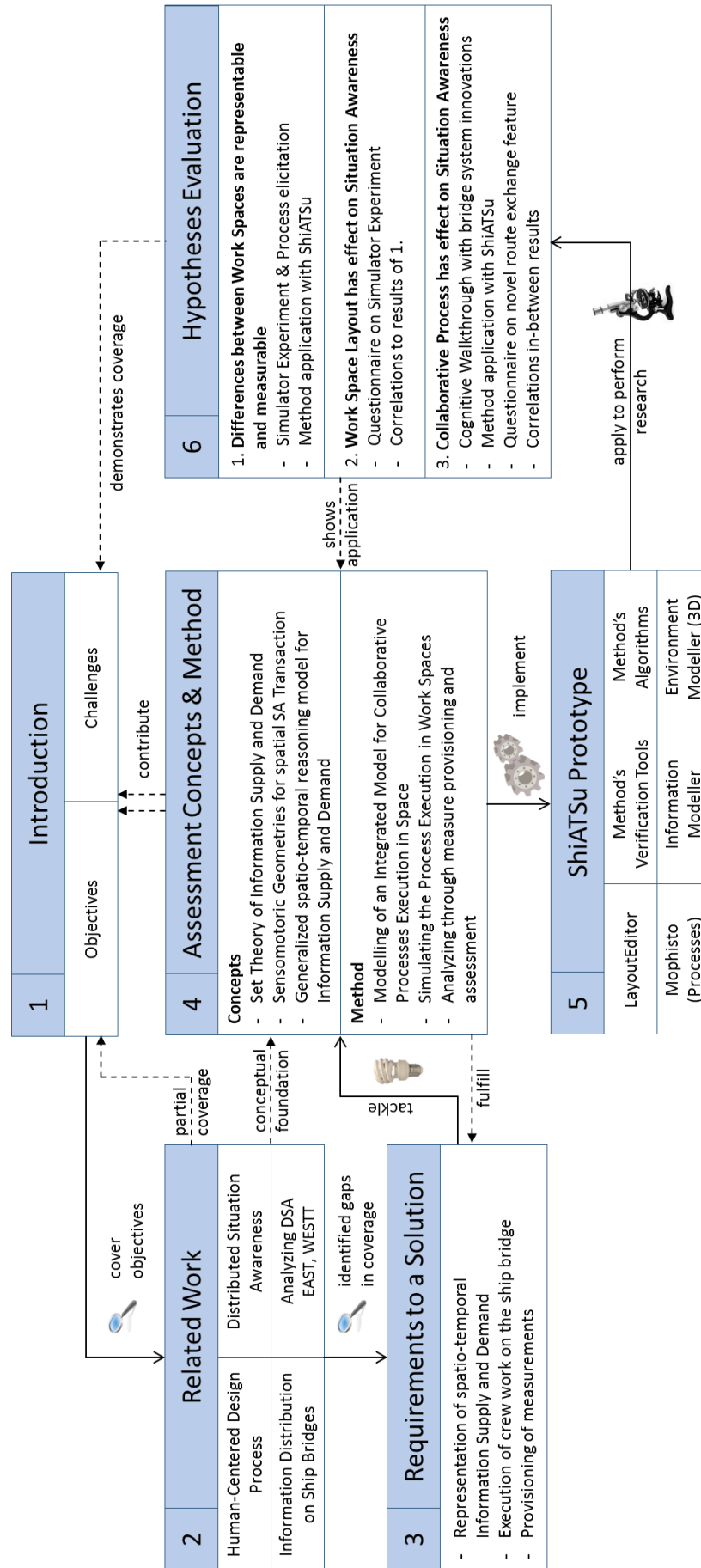

Figure 4: Chapter Overview

## *Chapter Overview*

---

reasoning model for information supply and demand. The method comprises them within three steps. 1. Modelling of an Integrated Model for Collaborative Process Execution in Space, Simulating the Process Execution in Work Spaces, and Analyzing the simulation outputs with provisioned measures and their assessment.

The software artifact - called ShiATSu - is presented in chapter 5, where insights into its software architecture and implementation are given. ShiATSu is a tool suite which supports the three-step method. ShiATSu is applied to perform research in chapter 6.

Chapter 6 describes three hypotheses evaluations, which have been executed with ShiATSu. The hypotheses are that, 1. Differences between Work Spaces are representable and measureable, 2. Work Space Layout has an Effect on Situation Awareness, and 3. Collaborative Process has an Effect on Situation Awareness. The evaluations show the applicability of the method and give a more exhaustive demonstration on objective coverage. Insights on proofs or falsifications of the hypothesis are given. A comprehensive pictorial chapter overview is given on Figure 4.

## 2 Related Work

This chapter examines methods and techniques, which form the baseline for this thesis' contribution. The aim is to cover the research objectives from chapter 1.3 and to identify the thereon-based chances for improvement to the State of the Art.

The ambition of this thesis is to enable for integration of the presented approach into nowadays ship bridge design. The human-centered design process, as defined in (ISO 9241-210 2011), is therefore a baseline to standardized design processes, that delivers a process-embedding context for this work, which is described in chapter 2.1.

As mentioned in the introduction, today's ship bridge design lacks operational requirements in planning, design and construction. Therefore, chapter 2.2 indicates the aim of nowadays ship bridge design and shows how human-machine interaction is considered in the classification of a modern ship bridge.

Distributed Situation Awareness (DSA, chapter 2.3) is considered as a theory that provides a general systems perspective of Situation Awareness (SA) in bridge system design. The theory and its concepts are elaborated referencing a fictitious "overtaking a TSS" scenario.

DSA has been applied in analysis and design of various complex systems settings. The methods created for analysis and design of DSA are presented in section 2.4. For illustration of the methods a detailed "anchoring on a reede" scenario is used.

Finally chapter 2.5 describes the related work's coverage of this thesis' objectives, which allows deriving the requirements to a solution in chapter 3.

### 2.1 The Human-Centered Design Process (ISO 9241-210)

The International Organization for Standardization (ISO) was founded 1947 in Geneva (Switzerland). Their technical committees develop standards considering various needs. The technical committee working on ergonomics is the TC 159. According to the TC 159 "Ergonomics produces and integrates knowledge from the human sciences to match jobs, systems, products and environments to the physical and mental abilities and limitations of people. In doing so, it seeks to improve health, safety, well-being and performance" (ISO/TC 159 1997).

The standard ISO 9241 is a result of the TC's work. It is a multi-part standard for ergonomics of human-computer interaction (HCI). In the standard, a general base line description of HCI is

given and eight series are provided, which have a special foci on software ergonomics (100 series), human system interaction processes (200 series), displays and display related hardware (300 series), physical input devices - ergonomics principles (400 series), workplace ergonomics (500 series), environment ergonomics (600 series), application domains - control rooms (700 series) and tactile and haptic interactions (900 series).

In the 200 series for human system interaction the ISO 9241-210 provides a general process for integration of ergonomics into the HCI systems. The process “complements existing systems design approaches” and it “can be incorporated in approaches as diverse as object-oriented, waterfall and rapid application development” (ISO 9241-210 2011). The process is intended to be used for planning and managing projects that design and develop interactive systems (ISO 9241-210 2011).

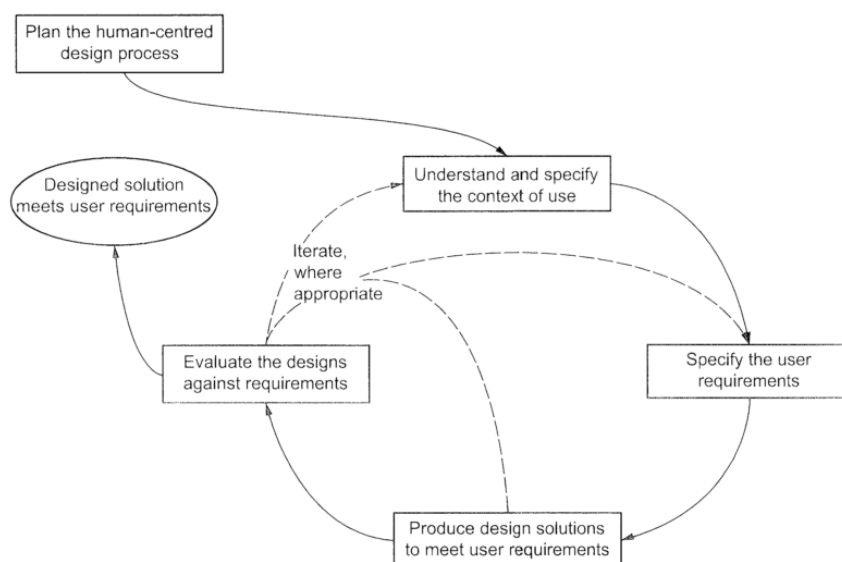

**Figure 5: Interdependence of human-centered design activities. Source: (ISO 9241-210 2011)**

The human-centered design process is iterative and contains activities, that are (1) understand and specify the context of use, (2) specify the user requirements, (3) produce design solutions to meet user requirements and (4) evaluate the designs against requirements, as depicted on Figure 5. The evaluation results decide on requirement fulfillment or (re-)iteration beginning in activity 1, 2 or 3. Of course an integration of ergonomics needs to be planned. Before starting these activities it is necessary to plan them. Therefore, the standard defines the planning in its section 5. There the responsibilities, contents of a plan, integration with the project plan, timing and resources are defined. The design process shall be planned and integrated into all phases of a products life cycle, i.e. conception, analysis, design, implementation, testing and

maintenance (ISO 9241-210 2011). In the following subsections the activities are briefly presented.

### **2.1.1 Activity 1 – Understand and Specify the Context of Use**

An understanding and specification of the context of use is standardized by creating a description of the *context of use*. This can be a textual description elicited via methods provided in (ISO/TR 16982 2002) about “usability methods supporting human-centered design”. A comprehensive review of these methods, such as focus groups, personas, contextual enquiry, etc., is given in (Bevan 2009).

According to the standard, the context of use shall include:

- a) The users and other stakeholder groups.
- b) The characteristics of the users or groups of users.
- c) The goals and tasks of the users.
- d) The environment(s) of the system.

### **2.1.2 Activity 2 – Specifying the User Requirements**

Taking the context of use into account, the second activity focusses on specifying the user requirements. The users’ and other stakeholders’ needs are identified and specified in a document as requirements. Therefore, a document, which is persisting the requirements, shall include the following:

- a) The context of use.
- b) Requirements derived from user needs.
- c) Requirements arising from relevant ergonomics and user interface knowledge, standards and guidelines.
- d) Usability requirements and objectives, including measurable usability performance.
- e) Requirements derived from organizational requirements that affect the user.

Further, the second activity considers resolving of trade-offs between user requirements and ensuring the quality of user requirements specification.

### **2.1.3 Activity 3 – Producing Design Solutions**

For producing design solutions the standards suggest to carry out the following sub-activities:

- a) **Designing** user tasks, user-system interaction and user interface to meet the requirements from activity 2 and considering “the whole user experience”.

- b) **Making** a design solution “more concrete” e.g. by execution of simulations, using scenarios and prototypes.
- c) **Altering** the design solutions based on user feedback.
- d) **Communication** of design solutions for implementation.

For sub-activity **Designing** principles from ISO 9241-110 are applied. These are: suitability for the task, self-descriptiveness, and conformity with user expectations, suitability for learning, controllability, error tolerance, and suitability for individualization. Designing is further subdivided into **Designing Interaction** between user and system, and **Designing the User Interface**:

- **Designing Interaction** should include making high-level decisions (initial design concepts, essential outcomes), identifying tasks and sub-tasks, their allocation to users and system parts, identification of “interaction objects” required for task completion, identifying and selecting appropriate dialogue techniques (ISO 9241-12 - ISO 9241-17), designing sequence and timing (dynamics) of the interaction, and designing the information architecture of the user interface of an interactive system to allow efficient access to interaction objects.
- **Designing the User Interface** should use “the substantial body” of ergonomics and user interface knowledge in standards and guidelines for hard- and software. The ISO 9241 series on displays, input devices, dialogue principles, menus, presentation of information, user guidance, and other User Interface and accessibility guidelines shall be considered. Further, company internal guidelines, style guides and product knowledge shall be integrated and user expectations (e.g. ISO 1503) shall be obeyed.

After designing, the next step is **Making** the design solution “more concrete”. This means making proposals more explicit, allowing designers to explore several design concepts, incorporating user feedback early into the design process, evaluate alternative designs and improving quality and completeness of functional design specifications. Simulations, models, scenarios, mock-ups or other forms of prototypes may be created, and tested out to obtain feedback.

That feedback shall be used for **Altering** the design to an improved and refined system. Costs and benefits of improvements/changes shall be evaluated. It’s said, that early changes are the most cost-effective, thus project plans should allow sufficient time to apply changes as result to feedback. Evaluation methods are stated with Activity 4.

**Communication** to the design team, implementers and further stakeholders is briefly regimented in the ISO 9241-210: Communication may be done by provision of appropriate documentation, prototypes, embedding human-centered design experts into the process and into the development team. Design decision shall be argued/explained and justified, especially for trade-offs.

#### **2.1.4 Activity 4 – Evaluating the Design**

Having a design solution produced, evaluating the design is the consecutive activity to be executed. The evaluation shall be user-centered, meaning an evaluation based on the users' perspective. This can be done at early design stages in a project and be used to better understand the user, but this does not imply that evaluation is always practical or cost-effective in every stage. Real-life usage of a product, system or service is complex and requires a user-centered evaluation, as an essential element in human-centered design. "In such circumstances, design solutions should also be evaluated over other ways - for example, using task modelling and simulations", is stated in the ISO standard that also clarifies that these methods are still human-centered, even though users do not directly participate. Aims of an evaluation are:

- a) Collection of new information about user needs,
- b) feedback of strengths and weaknesses of a design solution,
- c) assessment of requirement achievement, and
- d) establishment of baselines or to make comparisons between designs.

The standard provides contents on a user-centered evaluation and methods on a management level, and subdivides the approaches into **user-based testing** and **inspection-based evaluation**.

**User-based testing** may be executed in any design stage. In early stages models, scenarios or sketches of concepts can be presented and used to ask for evaluation with users in real context. 3D models and wireframes are quoted as examples. Prototypes are ought to be tested by users though carrying out tasks with them. At later stages, assessments verify whether usability objectives, e.g. usability performances and satisfaction criteria, are met in the contexts of use. Field validation is a form of user-based testing, that is done through methods like field reports, incident analysis, near-miss reports, log files, defect reports, real user feedback, performance data, satisfaction surveys, reports of health impacts, design improvements, user observation as well as requests for changes.

**Inspection-based evaluation** can complement user-based testing and be valuable and cost-effective. It can eliminate major issues before user-based testing is carried out. It is suggested to be performed by usability experts, who judge on prior experience and their knowledge of ergonomic guidelines and standards. An inspection may be further supported by e.g. checklists, industry best practices and usability heuristics. An inspection is simpler, quicker and does not always find same problems as user-based testing. Inspection is concerned with obvious problems and may not scale for complex or novel interfaces. Reasons are discrepancies between inspectors and users in knowledge and experience. Still, there is a risk that compliance assessments can be time-consuming and resource-intensive.

## **2.2 Information Distribution in Nowadays Bridge System Design**

In nowadays naval architecture engineering, the design of a ship bridge is accomplished by engineering to fulfill a set of standards, guidelines and regulations. Therefore, shipyards and ship builders execute custom procedures which serve to satisfy the requirements within these. Their satisfaction is typically required by ship classification societies, such as Lloyd's Register (LR), American Bureau of Shipping (ABS), Bureau Veritas (BV), China Classification Society (CCS), Germanischer Lloyd Det Norske Veritas (DNVGL), etc. A classification society's aim is to promote safety of life, property and environment through creation and assessment of technical and engineering standards for design, construction and maintenance of ships, offshore units and other naval architectures. These standards and guidelines are in accordance with flag state legislation. A classification society's assessment for requirement fulfillment is typically carried out for new builds, retrofits and in regular intervals, and leads to the decision whether the assessed architecture (ship) will get a class, keeps a class, be downgraded or declassified. The classification is important, since most ports world-wide require ships to be classified. For instance, in all European waters classification is required.

This section further describes on an excerpt of the standards, which consider the bridge information distribution and the human factor. Therefore, standards from IMO and DNVGL are considered.

### **2.2.1 Function-oriented Layout of Workstations**

IMO's NAV 45/6 "Ergonomic Criteria for Bridge Equipment and Layout" standard (IMO 1999) considers a function-oriented layout for ship bridges. The document defines eight function areas and recommends equipment to be placed in these areas. There is no explicit



recommendation where these areas shall be aligned on the bridge, but the document gives an example for functional area locating, which is depicted on Figure 6. In the document's subsection 5.1.2 vague constraints for positioning are defined. E.g. the position for "navigating and maneuvering should be laid out if practicable, at the starboard side close to the center-line beside the workstation for manual steering" (IMO 1999).

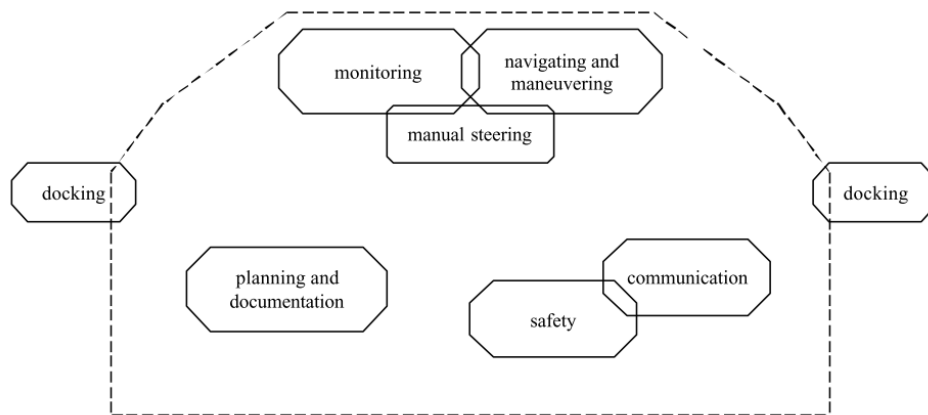

**Figure 6: Example of function areas. Source: (IMO 1999)**

NAV 45/6 lists various requirements for workstation areas. E.g. for navigating and maneuvering, monitoring and for bridge wings NAV 45/6 requires to leave space for at least two operators, but all workstation's equipment shall be close to be operable by one operator. (IMO 1999) These workstation areas shall obey the operators' Field of View.

Between workstations, standards require passageways, which allow operators to directly access the workstations, without detour. Spacing between the workstations, but also deckhead height should not restrict the access. Minimum spacing and heights are defined in millimeter precision. (Germanischer Lloyd 2012)

### **2.2.2 Task-oriented Layout for Integrated Navigational Systems (INS)**

The configuration for INS (IMO 2007) is set to be task-oriented and considers the tasks "route planning", "route monitoring", "collision avoidance", "navigation control data", "status and data display" and "alter management". These tasks require defined functions and data, which are integrated in so-called multi-functional "task stations". "Multi-functional" in this case means that a task station can switch in-between different task modes, thus task stations can also be called *multi-functional consoles* (MFC). The MSC.252(83) standard requires to carry a minimum of three MFCs, one for each of the tasks "route monitoring", "collision avoidance" and "navigation control data". Further, the standard requires additional MFCs to fulfill the

complete set of tasks. (IMO 2007) For layout allocation MSC.252(83) references the circular MSC/Circ.982, which contains the NAV 45/6 (previous section).

### 2.2.3 Displays in Field of View

On workstations, the left-to-right viewing angle is defined to not exceed 190°. Most important or frequently used displays should be located within the operators' *immediate field of view* and the *preferred viewing area* should be reserved exclusively for the most important display.

Figure 7 illustrates the horizontal *Field of View* (FoV), with a Preferred Viewing Area that is described with a 15° cone.

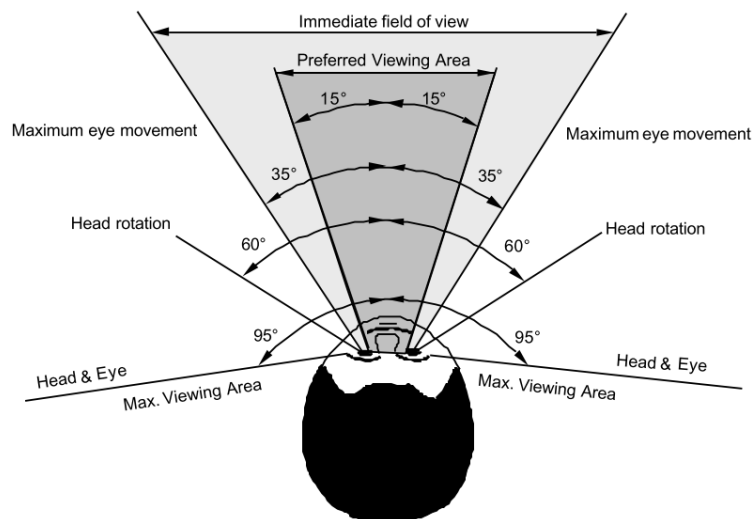

**Figure 7: Horizontal Field of View. Source: (IMO 1999)**

The DNVGL eases these angles by introduction of *priority zones* for indicators. There (DNVGL 2014, p.38) exist two zones: *A - easy readable* within a horizontal sector of 180° and vertical in the area up 60° and down 90° from the operators line of sight, and *B - readable* with a wider horizontal sector of 225°. Hence, easy readability can include head and body movements.

### 2.2.4 Access to Controls

Similar to the regulations described above, regulations for access to control equipment exist. DNVGL's *Rules for Ships* (DNVGL 2014) define reaching areas for operation on consoles. In the standard operators are positioned seated in a working area. From the seated position an *on hand area*, a *within easy reach area*, and a *within reach area* is defined. For maneuvering of offshore vessels control equipment is assigned to these reach areas. The areas are depicted on Figure 8.

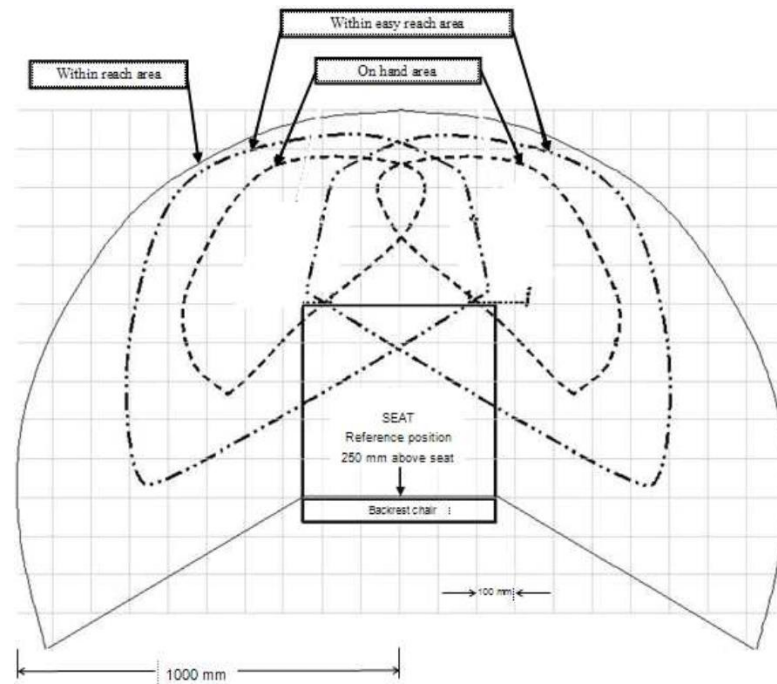

Figure 8: Classification of reaching areas from (DNVGL 2014, p.38)

### 2.2.5 Audible Alarms

On a bridge, audible alarms shall be used to get the crews' attention. According to the ergonomic criteria in (IMO 1999) these sounds shall have a sound pressure, that is at least 75 dB(A) from 1 meter distance measured from the sound's source, and 10 or preferable 20 dB(A) above the ambient noise levels on the bridge, but not exceeding 115 dB(A). Further, frequencies between 200 Hz and 2500 Hz shall be used. In (DNVGL 2014) alarms, which shall be sounded, are defined for each piece of equipment.

### 2.2.6 Working Environment

The limitations to design of the working environment, which encloses consoles and equipment, are defined e.g. in DNVGL's *Rules for Ships* (DNVGL 2014). Therein, limitations are set out for e.g. deckhead height and passageways. Passageways and deckhead height are limited as depicted in Figure 9. It is defined that direct access shall be provided to workstations (indicated with blue dots) via passageways. Distances between consoles as well as between consoles and the bridge room's hull are defined. The deckhead height is considered with (from left to right) height for doors (2000mm), deckhead panels and instruments (2100mm), and clear deckhead height (2250mm). Of course there exist plenty more influential factors in a

bridge's working environment, such as temperature, ventilation, illumination and coloring. These are considered by the rules and need to be obeyed during design.

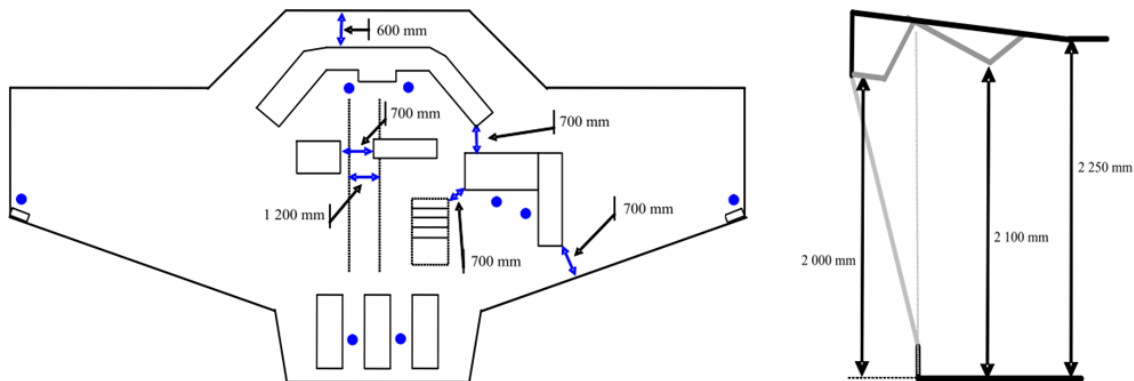

**Figure 9: Passageway limits between workstations and deckhead height from (DNVGL 2014)**

### 2.2.7 Further Standards

Besides the NAV 45/6 for ergonomic criteria, NAV 55/4 for IBS, MSC.252(83) for INS and the Rules for Classification of DNVGL, there exist several other standards, regulations and guidelines, which need to be obeyed during nowadays design. The following standards are integrated into these: e.g. ISO 8468 on ship's bridge layout and associated equipment, IEC 61924 on the modular structure of INS and the withdrawn IEC 61209 for IBS respectively.

## 2.3 Distributed Situation Awareness

The theory of Distributed Situation Awareness (DSA) is another foundation for this thesis, which provides a systemic perspective on Situation Awareness. This is fundamentally distinct to the individualistic approach of Situation Awareness. This chapter first describes the individualistic approach to Situation Awareness of Endsley (chapter 2.3.1), before introducing the theory of DSA of Salmon et al. (chapter 2.3.2).

### 2.3.1 Individual Situation Awareness

Situation Awareness (SA) is the degree to which an agent is aware of a situation, or in even easier words it's the understanding of an agent of what is happening around him (Endsley 1995a; Salmon et al. 2009). In research, definitions and models of SA are discussed controversially and thus need to be treated with reasonable skepticism. A main difference between most definitions of the SA construct is to include or not to include the process of SA construction (Salmon et al. 2009).

The most used definition of SA was given by Mica R. Endsley. She describes SA as a cognitive product, distinct from the process of situation assessment. She defines “Situation Awareness is the perception of elements in the environment within a volume of time and space, the comprehension of their meaning, and the projection of their status in the near future.” (Endsley 1995a).

The central aspects of Endsley’s definition are illustrated with the example of an Officer who would like to overtake another ship in a TSS (Traffic Separation Scheme) as depicted in Figure 10: To build a sufficient SA the Officer has to perceive information about elements in his environment in the first place. This includes for example the status of his own ship, the position, speed and distances of/to other ships nearby and the conditions in the overall environment of the TSS. On the next level of SA, information is comprehended, interpreted and understood. Here the Officer may recognize from his perceptions that there is another fast ship that is already trying to overtake his ship and shall be monitored. From that comprehension and the monitored alteration of the other ship’s position information over time the Officer can forecast the other ship’s future position (projection). With this information he can estimate its speed and decide on overtaking his forerunner or safely waiting for the other overtaking ship.

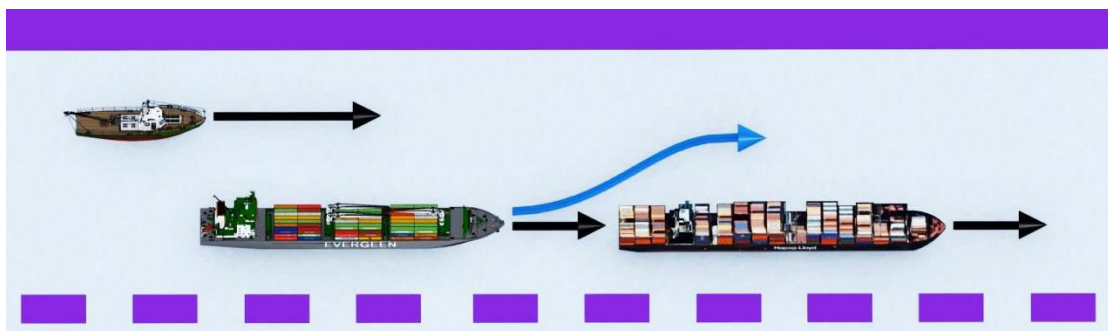

**Figure 10: SA Example - Overtaking in a Traffic Separation Scheme (TSS)**

The remainder of this chapter describes the Three Level Model of Endsley (Endsley 1995a) and the Perceptual Cycle Model of Smith and Hancock (Smith & Hancock 1995).

### 2.3.1.1 The Three Level Model

The Three Level Model (TLM) is based on Endsley’s definition and is the most applied model of SA. Analogue to the definition, the model distinguishes into three hierarchical levels of SA (perception, comprehension, projection), which are understood separately from the process to obtain SA. The TLM is depicted in **Figure 11**. Besides, these levels incorporate individual factors

(e.g. experience, skill, training), task factors (e.g. complexity of a task), and system factors (e.g. interface design). All these factors influence the individual human. An essential part of the model is that SA always depends on the goals which are pursued by the individual human. Depending on the current goal the relevance of certain information elements is set. If an Officer is planning to overtake his forerunner and then getting aware of a him-overtaking ship, he may change his goal from “overtake” to “follow forerunner”. With changing to the “follow forerunner” goal, the information about the him-overtaking ship gets irrelevant.

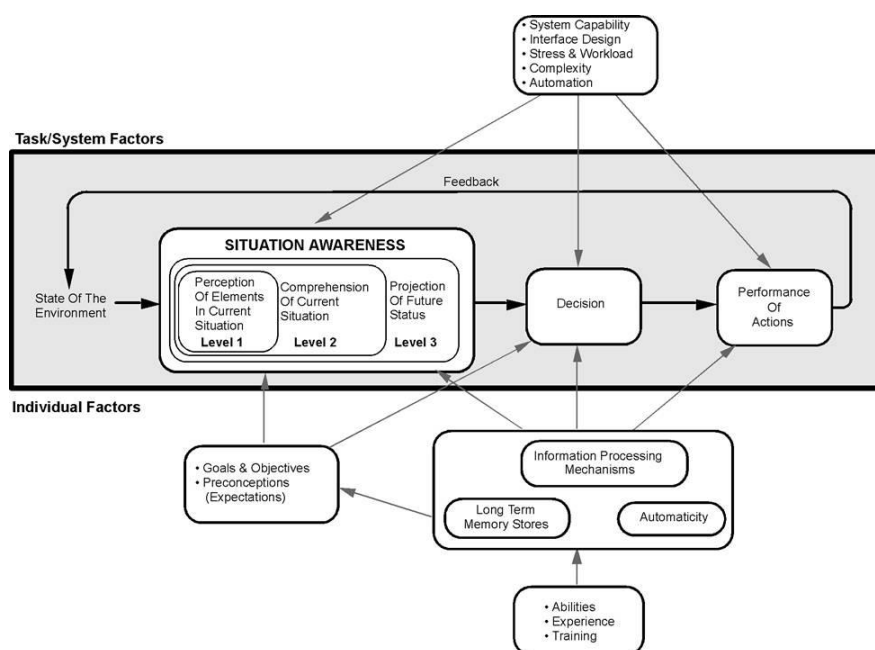

**Figure 11: Endsley's Three Level Model of Situation Awareness in the human decision-making cycle. Source: (Endsley 1995a)**

### 2.3.1.2 The Perceptual Cycle Model

The Perceptual Cycle Model (PCM) from Smith and Hancock (Smith & Hancock 1995) provides a more holistic view on SA than the TLM. The PCM builds up on Neisser’s Perceptual Cycle (Neisser 1976) and considers the process to obtain SA and the product SA. Thereby SA is not seen as a cognitive product of an individual, but arises from interactions of a person with his environment (Salmon et al. 2009). This implies that SA can be captured via observation.

Figure 12 illustrates the PCM. According to the model, the human perception of the environment is controlled by activated schemata (directs), which are a part of the human memory. Sampled information from the environment is modifying the memorized schemata. The modified schemata then again control the perception of the environment. SA is the product which arises from these everlasting interactions with the environment.

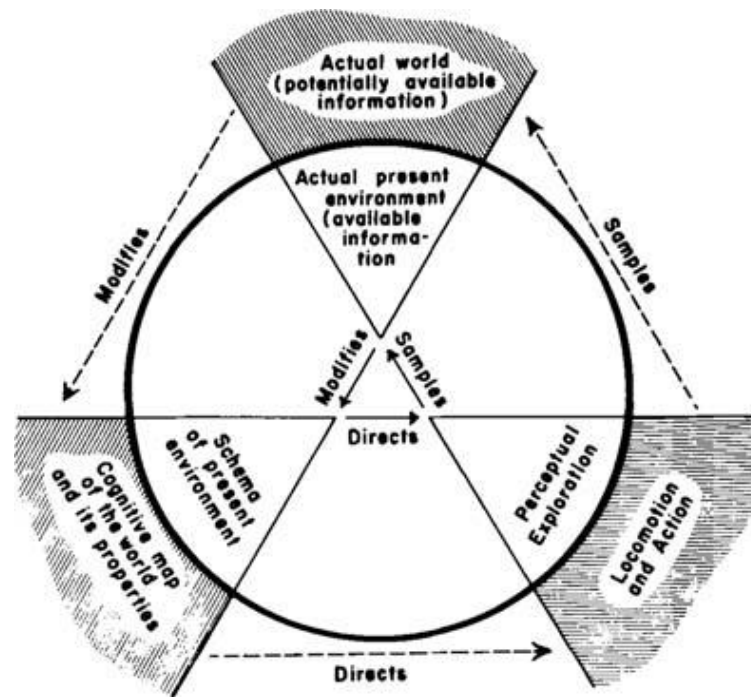

Figure 12: Neisser's Perceptual Cycle (Neisser 1976)

### 2.3.2 Distributed Situation Awareness

Where cooperative Human-Machine Systems are deployed, it is often necessary that distributed agents work together as a team to fulfill a common goal. Therefore, agents use artifacts, such as blackboards or computer monitors, which help fulfilling the task at hand. The bridge of a ship is an instance of such a system. For instance Masters and Officers are cooperating with each other and with the technical bridge systems (e.g. ECDIS and steering control), tertiary parties such as foreign ships via VHF radio and shore-based assistance such as VTS. In such a complex, collaborative scenario the individualistic approaches to SA are insufficient and impractical (Salmon et al. 2009). The main reason is that such scenarios and systems cannot be understood right through separated analysis of sole components. The theory of Distributed Situation Awareness aims to provide a holistic systems' view of SA.

#### 2.3.2.1 A Holistic Systems' Perspective

Distributed Situation Awareness (DSA) is based on the Distributed Cognition Theory (Hutchins 1995) which focusses on the analysis of overall systems. This includes all agents and artifacts. Cognition is thereby seen as a function of the overall system, which exceeds the borders of sole actors and appears as a phenomenon distributed across the whole system (Hutchins 1995; Salmon et al. 2009). Distributed cognition can be analyzed by observing interactions in-

between agents and in-between agents and artifacts (Salmon et al. 2009). DSA follows this approach and defines SA as an attribute of the overall system that exceeds the borders of a sole agent and constitutes from the interactions of agents and artifacts system-wide. To illustrate the perspective of DSA recall the “Overtaking in a TSS” scenario from Figure 10. In this scenario the Officer on the center ship was distracted and did not recognize the him-overtaking smaller ship aft. The Master of the overtaking ship recognizes that the center ship’s Officer is not reducing speed and thus gives him a radio call to ask for his intentions. The Office recognizes the overtaking ship and reduces his speed. By analyzing this scenario for individual SA, the results are that the Officer performed badly and the Master of the overtaking ship performed well. But, from a holistic systems’ perspective the analysis result yields the rationale that the systems SA was good in all states to enable safe and efficient shipping. At this point a legitimate question is, whether it is really necessary that every agent possesses a high individual SA, or whether it is sufficient that the overall system possesses a sufficient SA. Especially in complex collaborative systems, consisting of plenty agents, it seems to be sensible that not every agent can possess high SA in every point in time. A decrease of SA of an agent can be compensated by other agents in a way that the overall system has a high SA.

### **2.3.2.2 Compatible Situation Awareness**

Besides DSA’s perspective on SA as a system’s attribute, but not as a cognitive product, there exists another substantial theoretical difference to other SA approaches. This difference refers to the comparison between multiple agents’ individual SA. Where Endsley’s approach fosters the idea of a shared SA between multiple agents (Endsley & Jones 2001), DSA uses the concept of compatible SA. Since SA is strongly influenced by individual factors (e.g. experience, skill, training) and goals of an agent, it’s unlikely that two agents have an identical SA over an element in the environment (Salmon et al. 2009). Even if they have perceived the same information, their usage differs through alternative purposes. The concept of compatible SA respects this difference and states that the subjectivity of an agent’s SA requires compatibility for collaborative work with other agents.



**Figure 13: Shared Situation Awareness (left) vs. Compatible Situation Awareness (right)**



### **2.3.2.3 Situation Awareness Transactions**

Communication and coordination are critical factors to achieve SA in complex collaborative systems. In such systems relevant information is often distributed and thus needs to be communicated within the system. Within the DSA approach this exchange of SA-relevant information is done with so-called SA Transactions (Salmon et al. 2009). SA-relevant information elements can be exchanged in-between agents, between agents and artifacts and in-between artifacts. Exchanged information elements trigger an update on the SA of the receiving agent or artifact. In the shipping example such an update is the reception of the Master's call to the Officer of the center ship. A SA Transaction can be done via every modality, e.g. directly verbal, also via radio communication (as in the example), visually (e.g. via signs), or facilitate any other means of communication (e.g. sending a message to a display). A SA Transaction is successful on reception of information by the receiving party.

### **2.3.2.4 Distributed Situation Awareness Model**

With the aim to deliver a complete description of DSA Salmon et al. (Salmon et al. 2009) have built the DSA Model for DSA in complex collaborative systems. The model is depicted in Figure 14. Its underlying theories and constructs are schema theory, the Perceptual Cycle Model (PCM), Compatible SA and SA Transactions.

In the model, DSA is understood as an attribute of the overall system, that emerges from interactions (SA Transactions) between the agents and artifacts (Salmon et al. 2009). Every agent and artifact possesses his individual SA as a part of the overall system DSA. The individual SA is thereby not identical, but compatible to each other. SA Transactions are used to communicate SA-relevant information within the system. Analogue to Endsley's model (chapter 2.3.1), individual SA is influenced by individual factors. Within the DSA model these factors additionally include the agents' role in the system and the additionally resulting SA requirements. In contrast to Endsley's model task and system factors are not influencing the individual SA directly, but influence the overall system, hence the system's DSA. Further additions are team factors, such as team attributes and team processes, which influence the system's DSA.

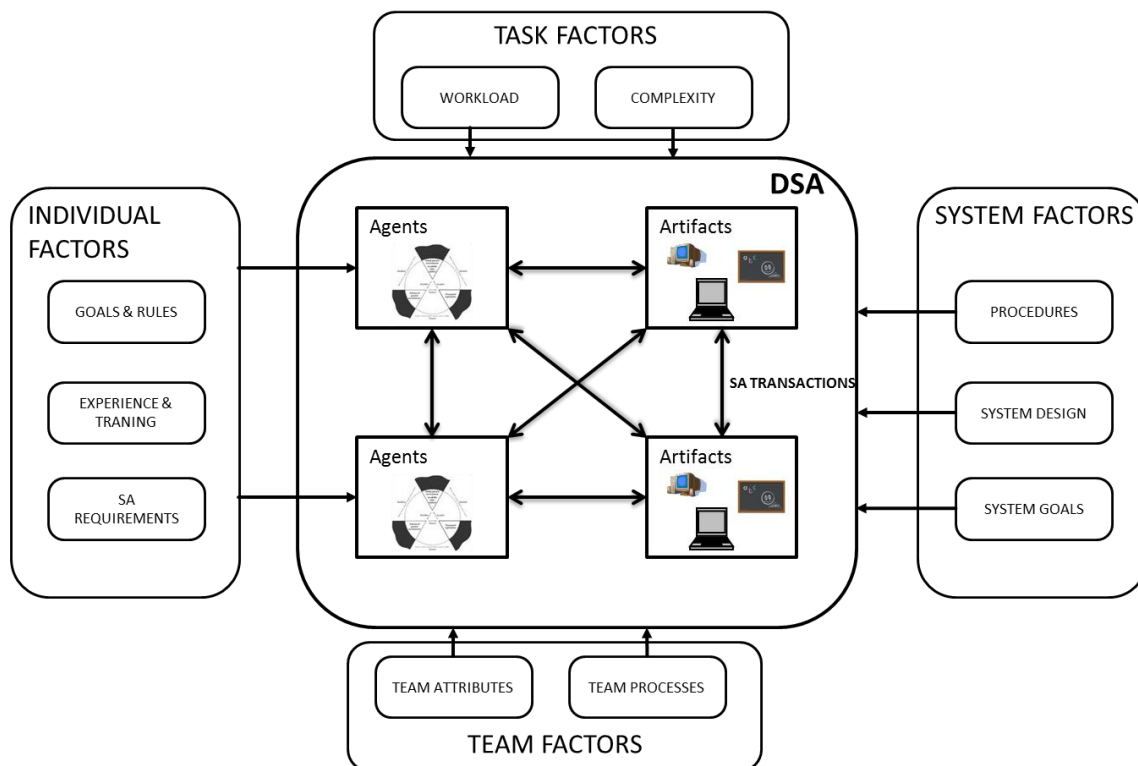

**Figure 14: Model of Distributed Situation Awareness in Complex Collaborative Systems**

*(Salmon et al. 2009, p.184)*

## 2.4 Analyzing Distributed Situation Awareness

Since DSA emerges from interactions, it is possible to directly observe the DSA of a system. A misconception that Endsley came up with in (Endsley 2015) is that DSA has no accompanying methodology that is supporting the design of systems or to undertake the analyses of DSA in the wild. But this assumption is incorrect (Stanton et al. 2014). Up to the current state there exist two methods which can be applied to support the design or analyze existing systems, these are the methods: Event Analysis of Systemic Teamwork (EAST), and Workload, Error, Situational awareness, Time and Teamwork Method (WESTT).

### 2.4.1 Event Analysis of Systemic Teamwork

The Event Analysis of Systemic Teamwork (EAST) (Salmon et al. 2005) is an analysis method that incorporates a network approach to describe DSA. The method comprises a 12-step procedure that yields three network models (Task, Social and Information Network) and their combination. In the past, the method was applied to model DSA (e.g. (Baber et al. 2013)) and

was used to assess DSA in various complex naturalistic settings (e.g. submarine (Stanton 2014), road safety (Walker et al. 2013) and energy (Salmon et al. 2008)).

EAST is applicable to all system levels: micro (i.e., individual human-machine-interaction), meso (i.e., organizations operating highly automated systems) and macro (i.e., multilayered networked system). This means that the troika of networks can be created on any of these levels, as each system level can be a distributed cognition system. Further, the levels can be nested, such that e.g. a micro system is included in a meso system. In Systems Ergonomics Wilson (Wilson 2014) defined six characteristics which are described with the table in Figure 15 about the EAST method. (Stanton 2014)

<b>Characteristic</b>	<b>Property of EAST</b>
Systems focus	Captures the whole socio-technical system in the network analysis and does not favour one system over the other.
Context	Analyses system behaviour at work using observed and recorded data from a context with input from Subject Matter Experts. System boundaries are defined by subject matter of interest and may also emerge from the analysis conducted.
Interactions	The interacting parts of the system are revealed in the three networks and the relationships between the networks, as indicted in Figure 14. Thus both interactions within and between networks can be analysed showing distributed cognition in terms of task-social, task-informational, social-informational and task-social-informational interactions.
Holism	The networks are analyzed as a whole, both quantitatively (using Social Network Analysis (SNA) metrics) and qualitatively (using network archetypes). The networks are also superimposed upon each other to produced combined networks.
Emergence	The emergent properties of the system are revealed through the SNA metrics and the network archetypes.
Embedding	The method itself is embedded in the communications and systems engineering disciplines, so it offers familiarity to organisations wishing to scrutinise their socio-technical systems. It has the benefit of representing the networks in graphical form as well as supporting metrics for detailed analysis.

**Figure 15: Six system characteristics of EAST according to (Wilson 2014) from (Stanton 2014)**

#### **2.4.1.1 The 12-Step Method**

In the **first step** of EAST, scenario(s) are defined that are in focus of the analysis. In the **second step** the analyst conducts Hierarchical Task Analyses (HTA) (Annett 2003) for the focused scenarios. With the HTA, the analyst persists his expectation about how tasks are executed. EAST advises to do this in collaboration with a relevant SME. **Thirdly**, an observation is planned for the defined scenarios. This involves planning observers for different locations and agents.

At his stage it is defined which information will be collected. Recording equipment should be clarified as well. Trail runs of the scenario should be executed, if time permits. The **fourth step** is the most important: the observation. "All activity involved in the scenario under analysis should be recorded along an incident timeline, including a description of the activity, the agents involved, any communications made and the technology involved. Additional notes should be made where required, including the purpose of the activity, any errors made and also any information that the agent involved feels is relevant." (Salmon et al. 2005, p.10ff). In the **fifth step** a Critical Decision Method (CDM) (Horberry & Cooke 2010) is executed with all agents in the scenario. For every incident on the incident time line the agents describes what could go wrong and which interactions the agent would have executed. This is especially useful if an execution path in the scenario was not executed. In **step six** all captures from the scenario and the CDM are transcribed. The transcript includes descriptions of activities, agents involved, any communications means, technology that was used and a time stamp. Again an SME should review the transcript for validity. In the **seventh step** the HTA is updated. Through the observation the analyst should have gained more insight and understanding for the work and can rule out false assumptions from the initial HTA or even detect discrepancies in-between how work should have been done and how work was done. In the **eighth step** a Coordination Demands Analysis (CDA) extracts teamwork tasks from the HTA and rates the tasks with the CDA taxonomy (Burke 2004). In the **ninth step** a Comms Usage Diagram (CUD) (Watts & Monk 1998) is created that represents the communication between the agents and also the technological means for communication (e.g. radio, telephone). In the **tenth step** a Social Network Analysis (SNA) (Driskell & Mullen 2004) is conducted to analyze the relationship between agents involved in the scenario. For EAST the software Agna SNA is used. From an constructed association matrix of agents, a social network diagram is constructed and agent centrality, sociometric status, and network density are calculated (Salmon et al. 2005). In the **eleventh step** an Operation Sequence Diagram (OSD) (Kirwan & Ainsworth 1992) is constructed by the analyst that should contain every operation described in the scenario transcript and the associated HTA. Results of the CDA are annotated to the operations of the OSD as well. Finally, in the **twelfth step** propositional networks are constructed for each step in a scenario identified via the CDM. This is done by identifying information, artifacts and action and creating nodes in the propositional network. Next, the nodes are linked with the following links taxonomy: has, is, causes, knows, requires, prevents.

The classical EAST method incorporates plenty techniques that can be very exhaustive, time consuming and require prior knowledge of the applied techniques. Especially the construction

of an HTA and OSD are said to consume the most time. Further, the results of the CDM depend on the skill of the analyst to ask the right questions and the SME for quality checks. (Salmon et al. 2005)

#### 2.4.1.2 The Network of Networks Approach

A more simplistic EAST method, that encounters the classical method's disadvantages, is proposed by Stanton (Stanton 2014). There the aim is to construct a network of networks as depicted in Figure 16. Simplistic EAST uses Step 1, 3 and 4 of Classical EAST and then builds and analyzes the network of networks. Hence, the method is:

1. Define scenario,
2. Plan observations,
3. Observe the scenario,
4. Create the networks from observations and captures,
5. Combine and analyze the networks.

The aim of this method is to build a network of networks, as depicted in Figure 16.

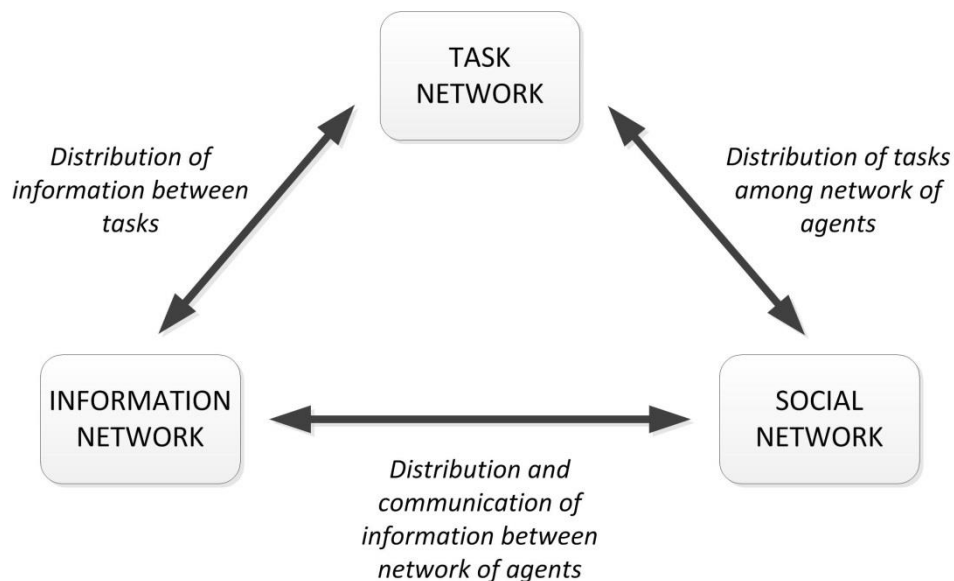
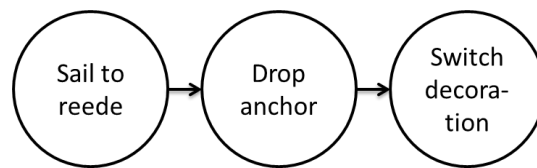

**Figure 16: Network of networks approach. (Stanton 2014)**

The Task, Information and Social Network are described below. These networks can be further combined to show the distribution of information between tasks, the distribution of tasks among the agents and the distribution of communication of information between agents. As every network in network theory, these networks consist of edges and vertices.

## Task Network

In a Task Network of EAST the vertices are used to describe the tasks. The edges are directed and indicate the order of the tasks in a work flow. A Task Network can be conducted from the main activities that need to be accomplished to fulfill the task in the scenario at hand. Therefore, captured data, such as transcripts, can be used to elicit a Task Network. But there are also other ways, e.g. Stanton's sub marine return to periscope depth (RTPD) scenario (Stanton 2014) could have been constructed from Standard Operating Procedures (SOP). Figure 17 shows an abstract Task Network for "anchoring a ship on a reede".

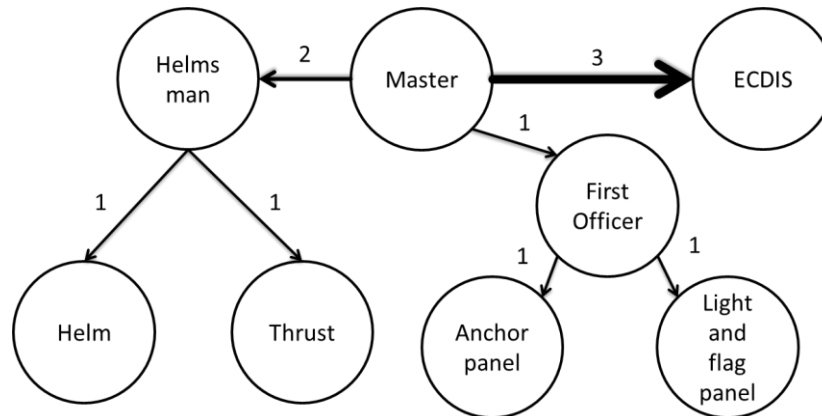

**Figure 17: Exemplary Task Network for anchoring on a reede**

To sail to the nearby reede the Master orders the Helmsman to change the course and reduce the speed. When closer by, the Master checks wind, current and nearby ships on the Electronic Chart Display and Information System (ECDIS) and decides how and at which position to anchor exactly by telling the First Officer. Having reached the position the First Officer uses the anchor winch to drop the anchor. Shortly afterwards, he changes the display of flags and lights to be in accordance with the rules.

## Social Network

The Social Network is created from the observations as well. In the Social Network the vertices represent the agents, here the Master, Helmsman and First Officer, and artifacts, here Helm, Thrust, Anchor panel, Light and flag panel and ECDIS. The edges represent a communication between the agents and artifacts and are directed from sender to receiver. To build up the Social Network depicted in Figure 18, an association matrix is build which is used to count the interactions between agents and artifacts. Then the Social Network can be created on the base of the matrix. The edges' weightings represent the communication count between the agents and artifacts. Thickness of edges is used to display the count visually.

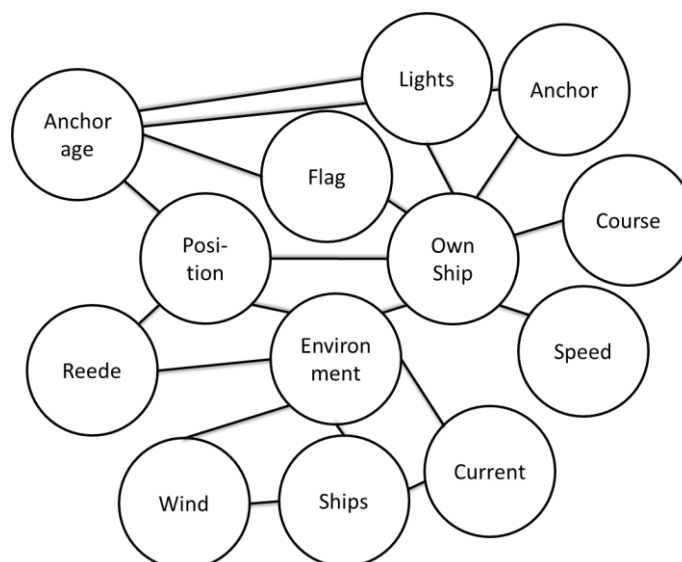

**Figure 18: Exemplary Social Network for anchoring on a reede**

### Information Network

The Information Network is created from transcripts of the observation. The transcripts are used to identify ‘concepts’ and to pair them with their nearest related vertices (i.e. other ‘concepts’ from the same scenario). This results in a network of information concepts. The network holds information of every agent and artifact and thus holds all information that can be part of the system’s DSA during a scenario run.

Figure 19 shows an exemplary Information Network that was constructed for the “anchoring on a reede” scenario. Here, additional information concepts have been derived from the scenario description to illustrate the relations between the concepts.



**Figure 19: Exemplary Information Network for anchoring on a reede**

## **Analysis of the Networks**

Simplistic EAST suggests analyzing all three networks with Social Network Analysis (SNA) (Driskell & Mullen 2004). SNA facilitates graphical and mathematical procedures to describe Social Networks. Typically in an SNA, measures for individual agents and for the whole network are calculated. Thus the measures allow to analyze individuals within the network and to classify the network's structure. The following set of metrics are examples to analyze individual agents (Stanton 2014):

- **Emission** and **reception degree** are the number of links from, and going to, each agent in the network.
- **Eccentricity** is defined by the largest number of hops an agent has to make to get from one side of the network to another.
- **Sociometric status** represents the number of communications received and emitted of an agent, relative to the number of overall network nodes.
- **Centrality** is calculated in order to determine the key agent(s) within the network. Centrality calculations can be made in various ways, e.g. by calculating Bavelas-Leavitt's index (e.g. in (van der Aalst et al. 2004) the index is well described).
- **Closeness** is the inverse of the sum of the shortest distances between each agent and every other agent in the network. It reflects the ability to access information through the nested network of agents.
- **Farness** is the index of centrality for each node in the network, computed as the sum of each agent to all other agents in the network by the shortest path.
- **Betweenness** is defined by the presence of an agent between two other agents, which may be able to exert power through its role as an information broker.

The second set of metrics can be applied to analyze the whole network (Stanton 2014):

- **Density** of a network is defined by the number of social relations that are actually observed and can be represented as some fraction of the total possible. Hence, actual links divided by potential links.
- **Cohesion** is defined as the number of reciprocal links in the network divided by the maximum number of possible links.
- **Diameter** defines the largest geodesic distance within a network. It is another metric of the network's size. I.e., the number of hops to get from one side of the network to the other.

Figure 20 shows an exemplary SNA of the anchoring on a reede scenario from the Social Network in Figure 18. Because the Social Network is not a digraph, meaning there is always only a one-directed connection between the agents, closeness and farness cannot be calculated. Further the figure does not show betweenness, since it is zero for every agent.



Agent Name	Reception	Emission	Eccentricity	Sociometric status	Centrality
Helmsman	1	2	1	0,375	0,2
Master	0	2	0,5	0,25	0,6
ECDIS	1	0	0	0,125	0
Helm	1	0	0	0,125	0
Thrust	1	0	0	0,125	0
First Officer	1	2	1	0,375	0,2
Anchor panel	1	0	0	0,125	0
Light and flag panel	1	0	0	0,125	0

**Figure 20: Exemplary Social Network Analysis for the reede anchoring scenario**

The networks density is 0,214, which is the result of 6 actual links divided by 28 potential total links. Cohesion is 0, since there are no reciprocal links, and diameter of the network is 2.

Of course this is just a small example, but it illustrates that these statistics enable the analyst to find the key agents and to identify the structure of the network (Stanton 2014).

### Combination of Networks

The three networks can be combined arbitrarily with each other in any combination to give additional insight on system's DSA. The combination of Task and Social Networks presents which agent is primarily involved in which task. By combining Task and Information Network, the analyst yields a distribution of information between tasks. Tasks requiring a huge amount of information elements require more effort for the overall DSA. Through the combination of the Information and Social Networks, an insight into the distribution of communication of information elements between the network agents can be gained.

Of course, it is also possible to combine all three networks into one. Figure 21 shows the combination to a Social-Task-Information Network for the anchoring on a reede scenario. With a glimpse at the visualization, it is apparent that the Master is involved in all Tasks and uses almost all information elements. This visualization shows all networks' vertices at once, but edges from the Task Network are missing. This implies that there is no consideration of time intervals, as indicated in the Task Network. In an analysis this may lead to false conclusions. E.g. in this case the information element "Own Ship" is used by three agents and during the task "Switch decoration", but during that task only the First Officer uses the "Own Ship" information element. To encounter this, the analyst can either use the combined networks of two or otherwise simply duplicate information elements, which are used by different agents at varying times, in the Social-Task-Information Network.

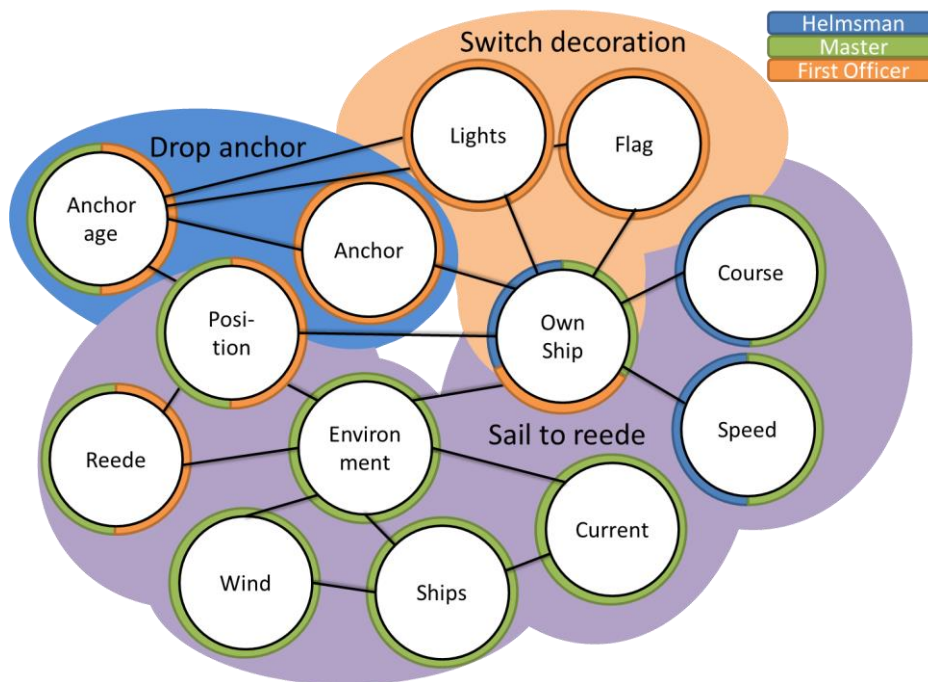

**Figure 21: Combined Social-Task-Information Network**

#### 2.4.2 Workload, Error, Situation Awareness, Timing and Teamwork

**Workload, Error, Situation Awareness, Timing and Teamwork (WESTT)** (Houghton et al. 2008) is a software tool and methodology aiming at integration of Human Factors into System Engineering.

Overall, the WESTT “takes a description of activity [from an observational study], in the form of a table of observations and generates a series of views and analyses to help the analyst consider the Operational Loading (Workload) on agents, the possibility of Error arising from performing activities, the knowledge required to perform activities and maintain Situational Awareness, the Social Network (Team) that the activity creates and the Timing of the activities. These outputs give the tool its name, Workload, Error, Situation awareness, Timing and Teamwork” (Baber et al. 2008).

The methodology is analogue to EAST. In the first step the Context of Use is defined, and an observational study is executed in the second step. Then, a third step, a so-called “WESTT analysis” is conducted. That creates the views to analyze workload, possible errors, SA, the Social Network and timings. Outputs of this analysis are used to construct a Class Diagram which shall be interpreted as requirements for User Interface Design (step four).

### 2.4.2.1 View Creation

The WESTT software creates the views: Therefore the user inputs data from the observation into the software in form of a data table. The data table represents the information flows row-wise. In detail, every row lists the function which consists of multiple performed operation names, which agents performed the operation, agent to agent communication, timestamp, and operation duration data. The software uses the table to create four diagrams that enable for the analyses: Sequence Diagram, Use Case Diagram, Text Analysis and Social Network Analysis.

#### Sequence Diagram

Sequence Diagram is an Interaction Diagram of the Unified Modeling Language (UML) (ISO/IEC 19505-2 2012). In computer science, its intent is to describe how processes operate with each other. Therefore, it depicts objects and classes with their temporal sequential message exchange order. An exemplary output of WESTT (Houghton et al. 2008) for the anchoring on a reede scenario is depicted on Figure 22. There the first interaction between Master and Helmsman is the call to change course *changeCourse()* to the Helmsman. The fourth call, *getWind()*, causes the ECDIS to return the wind information element. Also it is possible to express agents' internal processes, like *decideAnchorage()*, which can be used to express human decision-making.

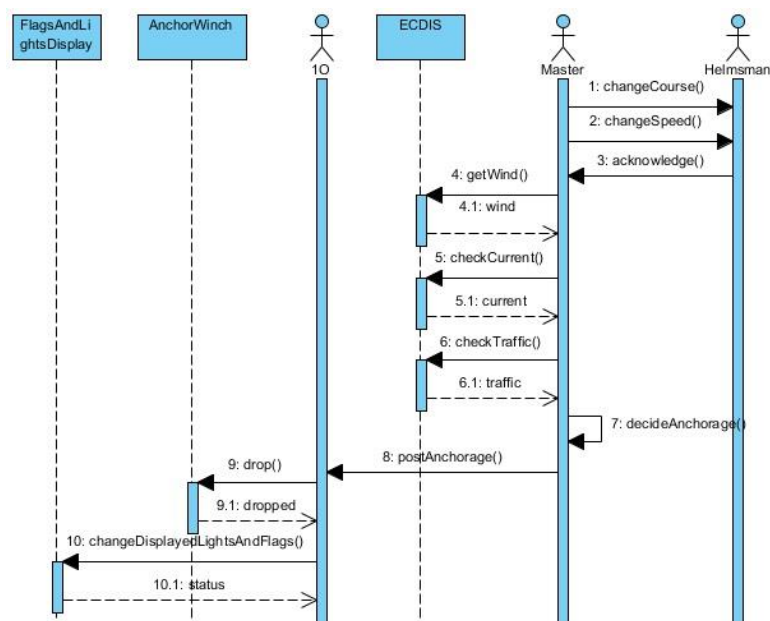

Figure 22: Sequence Diagram for anchoring on a reede

### Use Case Diagram

A Use Case Diagram (ISO/IEC 19505-2 2012) is another kind of UML diagram, that is applied to describe system behaviour as well. But, its focus is on functionalities of software systems, instead of detailed processes. On Figure 23, the “anchoring on a reede” scenario is defined as Use Case. It shows the functions *Drop anchor*, *Switch decoration*, and *Sail to reede*, which are associated to the connected users *Master*, *10*, and *Helmsman*. The association implies that a user requires the associated functionality from the (ship) system.

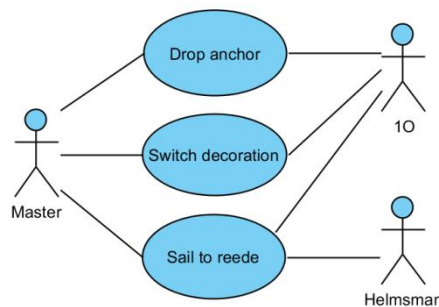

Figure 23: Use Case Diagram for anchoring on a reede

### Text Analysis / Propositional Network Analysis

WESTT supports a basic Text Analysis that creates a Propositional Network. The network’s nodes are names of concepts, similarly to the content of a mind-map (Houghton et al. 2008). To create the network, WESTT parses the operations-column from the data table, and filters them lexically for subjects, predicates and objects. The textual description of the “anchoring on a reede” scenario thus ends up in the Propositional Network depicted on Figure 24. The participating agents, their actions and information are marked-up e.g. with color coding.

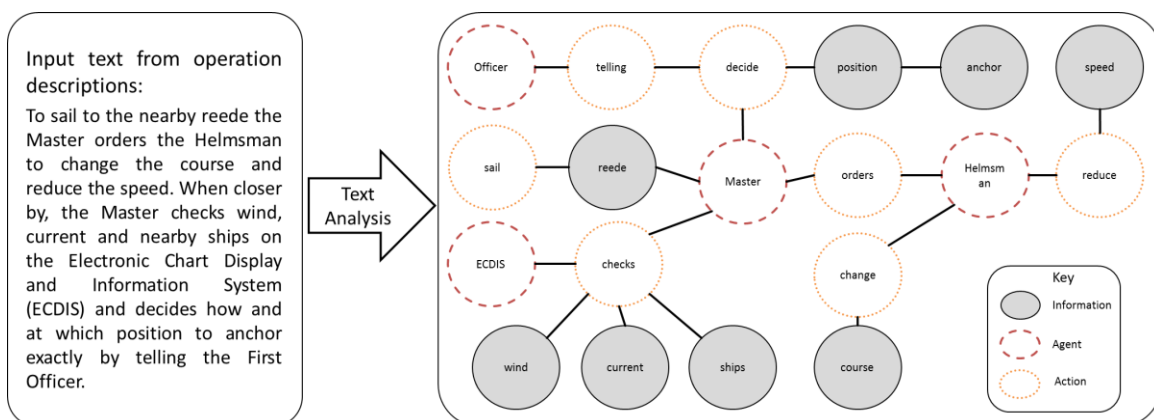

Figure 24: Exemplary Text Analysis by WESTT with resulting Propositional Network

The resulting Propositional Network is then refined manually, so that information elements referring to actions are grouped in a way that actions are always connected to two agents. If

there are not two agents connectable to an action, it may be f.i. that the Propositional Network misses agents, or that the action can be merged with another one. The result of the manual adoption is called a Composite Diagram, which is depicted for the exemplary scenario on Figure 25. There, e.g. the agent *Wheel* was added and the actions *telling* and *decide* were merged. With DSA theory the actions and information elements can be interpreted jointly as SA Transaction.

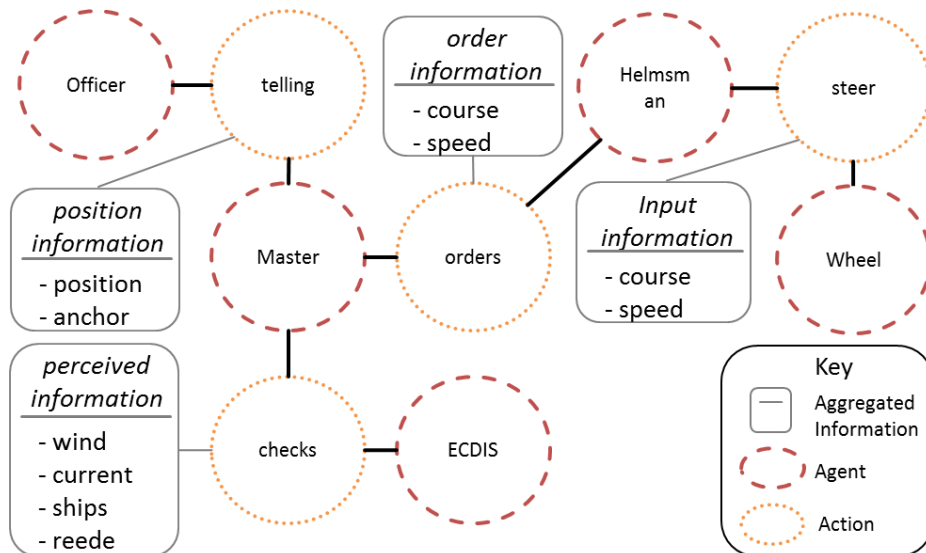

Figure 25: Exemplary Composite Diagram

### Social Network Analysis

The Social Network Analysis (SNA), described with EAST in the previous chapter, can be executed automatically with WESTT from the data table. Therefore, the columns for agent to agent communication are used to identify the nodes of the network.

#### 2.4.2.2 Deriving Class Diagrams

An output on the WESTT methodology is a UML Class Diagram (ISO/IEC 19505-2 2012), that describes the required interface between two agents. A Class Diagram is a static structure diagram, showing a system's classes with attributes, operations/methods and the classes' inter-relationships. With a WESTT-produced Class Diagram solely observed data from the initially chosen scenario are considered. Thus, interactions or work phases, etc., which are not part of the scenario, are not covered in the resulting Class Diagram. The Class Diagram is derived from the WESTT-created views. Aggregated information of the Composite Diagram can be elaborated with Use Case Diagrams (to show how agents share tasks), and with the results of the Social Network Analyses (showing how agents communicate).

Figure 26 depicts a non-exhaustive Class Diagram for a subpart of the exemplary anchoring scenario. The resulting Classes are then further aligned to the agents form requirements for User Interfaces. The (graphical) User Interface Design process is not part of the WESTT method and software, but WESTT-created Sequence Diagrams can help by giving insight into temporal operation execution, during the development.

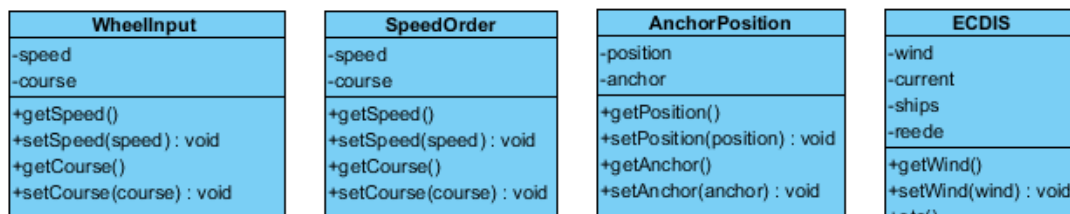

Figure 26: Excerpt of resulting Classes

## 2.5 Objective Coverage Summary

The methods and techniques presented in this chapter are the baseline to this thesis' approach. In this chapter the methods and techniques are rated for their contribution to objective coverage.

**Coverage of Objective 1** – *Integration of crew work organization and bridge information distribution during design time: partially covered.* DSA generally provides an integrated systems perspective of agents. WESTT and EAST can be applied to (re-) design interfaces. But, the DSA perspective lacks spatio-temporal dimensions. DSA can be examined for a point in time, but transactions between multiple time points are missing, meaning changes over time are not explicitly described with the DSA model. Spatiality of agents is missing completely, meaning locations of agents do not exist in the concept.

**Coverage of Objective 2** – *Consideration of sequential task and collaborative teamwork: covered.* EAST and WESTT provide graph-based means to express the order of task execution and collaboration between human agents, such as the sequence diagram or a propositional network diagram. Both methods focus on the creation of new human-machine interfaces with information elicited from field studies.

**Coverage of Objective 3** – *Consideration of dynamic information presentation: partially covered.* In DSA non-present information is equal to non-existent information. In WESTT the presentness of information is outsourced to an undefined User Interface Design process. Thus,

the general idea about dynamics in presentness of information is apparent, but not made concrete.

**Coverage of Objective 4 – Adjustment of crew work organization and bridge information distribution: not covered.** The INS standard considers MFCs that consist of multiple displays which are coupled to specific tasks. These require fixed information. In EAST and WESTT bridge information distribution and crew work organization are hard coupled as well. SA Transactions directly couple agents with a specific information element exchanged.

**Coverage of Objective 5 – Reusability of crew work organization and bridge information distribution: partially covered.** Gained knowledge from the presented methods and techniques can of course be generally reused, but cannot be separately reused. E.g. Social Networks from EAST would need to be recreated manually for new systems analyses.

**Coverage of Objective 6 – Formalization of bridge information distribution and crew work organization: partially covered.** None of the introduced current state methods or techniques provides a formalization of bridge information distribution and crew work organization jointly. In EAST and WESTT propositional networks and UML are used, which generally present a formalized depiction of DSA agents, information and interaction, but this is not a complete formalization, since the spatio-temporal aspect is not considered.

**Coverage of Objective 7 & 8 – Measurement of misfits between information supply and demand & Traceability of misfits: not covered.** There is no kind of detection or measurement of misfits in the related work. DSA covers observable interactions in a reality. This implies that missing information provision and gathering due to insufficiencies of agents is also not covered. The EAST and WESTT measurements are done with SNA analyses that allow analysis for e.g. potentially most relevant information and/or agents. Hence, if misfits between supply and demand do not exist, they cannot be traced with the methods and techniques in related work.

**Coverage of Objective 9 – Comparability of measurements: not covered.** The HCD-process' evaluation (Activity 4, aim d)) incorporates the establishment of baselines or to make comparisons between designs. In the described nowadays bridge system design standards, DSA Theory, and EAST and WESTT methods comparisons between designs are not explicitly considered. Thus, comparability between design alternatives exists only on the HCD process - on management level. The comparability is not covered, since no measurement method of information supply and demand exists.





### 3 Requirements to a Solution

As shown in chapter 2.5 on objectives coverage, this thesis' objectives are not completely covered in the related work. In this chapter requirements are engineered, whose fulfillment shall lead to full coverage of the objectives. In the following the requirements (R1 - R12) are structured in three requirement groups (RG1 - RG3) that are described in detail:

#### 3.1 RG1 – Representation of Spatio-Temporal Information Supply and Demand of Bridge and Crew

Requirements within this group directly correspond to RQ1 (see chapter 1.3), which asks for concepts, methods and techniques that are needed to represent spatio-temporal information supply and demand of bridge and crew. The objective coverage (chapter 2.5) showed deficiencies in the related work that does not allow answering the question. R1 to R3 are requirements that collaborate with the related work towards fulfilling RQ1's objectives.

- R1 – *Set theoretical concept for loose coupling of information supply and demand*  
The integration of crew work organization and bridge information distribution can be described with the concept of SA Transactions in the DSA model (compare chapter 2.3.2). Crew and bridge systems are therefore seen as agents interchanging information elements over SA Transactions. Adjustments to the crew work organization and/or bridge information distribution (compare adjustment classes in chapter 1.1), need to be transferred to the SA Transactions, to reflect a systems' DSA. In DSA theory and methods, there exists no concept that would allow reassembling SA Transactions on/after adjustments. A requirement in this thesis is therefore to create a concept that separates into an agent's supply and demand of information elements, and allows a comparison of a set of demanded to a set of supplied information elements. Based on supply and demand over an information element, SA Transactions between agents shall be instantiable which represents a loose coupling between two agents' supply and demand. This requirement contributes to Objective 1 (Integration of crew work organization and bridge information distribution during design time) and Objective 4 (Adjustment of crew work organization and bridge information distribution) by enabling the adjustment classes to be applied during design time on an integrated model. Further, R1's fulfillment contributes to reusability (Objective 5), since a conceptual separation into supply and demand shall allow separated reuse of

crew work organization and bridge information distribution models conceptually, and to the formalization objective (Objective 6), through fostering mathematic formal set theory. On the other hand this contributes to the assessment objectives measurement, traceability and comparability of supplied and demanded information elements. (Objectives 7 - 9). Through the nestedness to several objectives it's obvious: This requirement is critical to the overall approach.

- R2 – *Integrated and formalized model for spatio-temporality of crew work organization and bridge information distribution*

In EAST and WESTT graph structures in form of UML sequence diagrams and networks are used to express the work of agents. These enable to describe sequential task- and collaborative teamwork (Objective 2). But, a view on spatio-temporal issues emerging in and in-between the bridge information distribution and crew work organization (e.g. Captain can currently not access the course information, because he is too far away from the conning console) (Objective 1) is not considered. A requirement to a solution is to create a Spatial Model that integrates with a temporal model of sequential and collaborative work. The Spatial Model shall enable to describe physical locations of human agents (e.g. Master, OOW, Helmsman) and machine agents (e.g. bridge systems, consoles, equipment) with their information elements. This integrated spatio-temporal model shall allow inspecting DSA at a specific point in time and shall enable to derive the spatial changes of agents and artifacts over a temporal interval. The concept of SA Transactions shall be used to describe the interactions between agents and artifacts in the model. The fulfillment of this requirement is a precondition to RG2, that base on the resulting model. It covers the residual from the related work to fulfill Objective 1, jointly with R1, and integrates Objective 2 to consider sequential task and collaborative teamwork.

- R3 – *Symbolic verification of integrated model completeness*

The integrated model (R2), consisting of the temporal model for crew work organization and the Spatial Model for bridge information distribution, needs to provide a description of every information element that is described with the crew work organization. This means that SA Transaction must be producible from the integrated model which describes all supplied and demanded information from a crew's work process. Otherwise, an execution of crew work will fail. It is required that a solution verifies the existence of these descriptions. The verification is called symbolic, since it shall be executed with symbols from set theory and asserts the

---

existence of information elements used by the crew. Implications are that there is also no notion of space. As a result engineers are enabled to identify missing information elements on the ship bridge.

### 3.2 RG2 – Execution of Crew Work on the Ship Bridge

The integrated model required in RG1 shall be used for analyses described with RG3. With the requirements described in this group, execution of the integrated model is required to cater for dynamic aspects that occur during work. These are movements of agents and changes in presence that can be caused by interferences that influence access to information elements.

- R4 – *Creation of a ship work environment model*

The navigational crews' work environment is the ship bridge, which is described in the integrated model as a Spatial Model (see RG1). Besides bridge systems (machine agents), consisting of consoles and equipment for information supply and demand, human crew members (human agents) are typical physical objects, which work on the bridge. Of course further additional physical objects can exist in the environment, such as barriers or chairs (artifacts) that must be considered as a part of a ship bridge environment description, since they can influence the crew work. Physical objects are represented as three-dimensional arbitrarily complex geometries having a spatial volume. In reality, all these objects are typically enclosed by environment boundaries, such as walls, windows, doors, floors and ceilings. These boundaries of the ship bridge are to be considered as potential restrictive entities to crew work. E.g. a low-hanging ceiling may impede ergonomic access. The ship work environment is required to provide a three dimensional space that allows positioning of machine agents, human agents and artifacts. Further, as stated in the chapter of nowadays ship bridge design (see chapter 2.2), interaction modalities, such as vision, audition and taction, are relevant during design for accessibility evaluation. Thus, they shall be describable for physical objects.

- R5 – *Definition of deterministic crew work execution*

From an experimental perspective, the integrated model is an independent variable to the analyses described with RG3, declaring depended variables. The execution of crew work on the ship bridge thus is a control variable, which needs to be defined. To make the execution of work controllable, unified utility functions for human agent behaviour

for satisfaction of information supply and demand need to be defined, which are deterministic. Spatial movement and postural changes shall be considered, as they are part of the ergonomics assessment in nowadays design (see chapter 2.2).

- **R6 – *Definition of runtime dynamics in information distribution***

Likewise, crew work execution (R4), information distributed on the bridge consoles and equipment may be altered during work execution. Positions of information elements may change, be toggled in presentness, or the interaction modalities between agents may suffer interferences. Interferences can be induced by e.g. covering equipment or lowering or obfuscating acoustic signals. During execution of work these dynamics may occur, and thus they have to be definable for occurrence during runtime.

- **R7 – *Topological runtime verification***

With the introduction of a spatial environment to the integrated model, a new class of problems may arise while crew work is executed: Access to information may result in additional effort through ergonomical insufficiencies of the environment. Passageways between consoles may be too narrow (see chapter 2.2) and arbitrary physical objects may block the crew from reaching positions that allow access. Dynamics that are described with R4 and R5 may introduce such problems during crew work. Analyst adopting a spatio-temporal information supply and demand analysis shall therefore be enabled with this approach to verify the environment for the ergonomic insufficiencies.

- **R8 – *Crew work execution and capturing***

The verified environment shall be used to execute the crew work on the ship bridge. This execution shall incorporate the defined *representative crew work execution* (R5), the *runtime dynamics* (R6) and the *environment* (R4) to execute the SA Transactions defined in the *integrated model* (RG1). During execution of SA Transactions agents' positional and postural changes and further dynamics in the environment shall be captured, for measurements required with RG3.

### **3.3 RG3 – Provisioning of Measurements**

After execution of crew work (RG2), measurements need to be provided to the analyst, which help to assess the executed combination of crew work organization and bridge information

distribution. Therefore, this requirement group requires the development of qualitative and quantitative measures which provide a meaning and expression on the information supply and demand relation to an analyst.

- *R9 – Derivation of qualitative assertions about supply and demand relations*  
Qualitative assertions about information supply and demand relationship during the execution of crew work are required. The assertions shall allow the analyst to directly comprehend, which actions an agent had to take to execute an SA Transaction. Actions are positional changes, postural changes and changes to the presence of information on consoles and equipment. This requirement shall contribute to Objective 6 by requiring formalization for deductions of these assertions from captures of the execution (see RG2). Further, it contributes to Objective 7 in qualitative measurement of misfits between information supply and demand.
- *R10 – Derivation of quantitative assertions about supply and demand relations*  
The qualitative assertions shall be accompanied by quantitative measures, that are weightings to the qualitative assertions. These are ought to support interpretation of efforts coded in a qualitative assertion. Quantitative assertions shall measure the efforts of positional changes, postural changes and changes to the presence of information on consoles and equipment. This requirement contributes to Objective 7 in qualitative measurement of misfits between information supply and demand.
- *R11 – Detection of runtime dynamic interferences*  
Through the introduction of dynamics in RG2, interferences may impede the execution of SA Transactions. E.g. information on equipment could have been physically covered and did not permit an agent to perceive information. Interferences will be reflected by the qualitative and quantitative measures, but an analyst will be interested in problem resolution. Hence, a solution shall detect the causes of interferences and point the analyst towards the interfering problem.
- *R12 – Provision of analysis results*  
A solution to the problem is also required to present qualitative assertions (R9), quantitative assertions (R10), and detected interferences (R11) to an analyst. This shall be a summarized report on these analyses results about an integrated model's execution. It shall be in a unified form to allow for comparison between multiple integrated model results.



## **4 Assessment of Spatio-Temporal Information Supply and Demand Fitness**

In this chapter, the developed approach of this thesis is described in detail. The approach bases on the related work (chapter 2) and is set out to fulfill the necessary requirements (chapter 3). The approach has its context in the human-centered design process (chapter 2.1) and is designated for application during Activity 4 in early design stages as an inspection-based evaluation of a ship bridge design. To underline the explanations of the approach, a microscopic navigational Use Case is introduced in chapter 4.1.

The Use Case is facilitated to illustrate the concept and method proposed in this thesis. The method comprises three high-level steps that are modelling (chapter 4.5), simulation (chapter 4.6) and analysis (chapter 4.7). The method's steps are built upon three basic concepts: the set theoretical concepts of information supply and demand (chapter 4.2), the concept for sensomotoric geometries for transacting information supply and demand (chapter 4.3), and a concept for generalized spatio-temporal reasoning of information supply and demand (chapter 4.4).

This chapter is closed with a conclusion (chapter 4.8) that reviews the fulfillment of the requirements (chapter 3).

### **4.1 Use Case: Course Change in Open Waters**

To enhance comprehension of the approach presented in this thesis, an exemplary Use Case is introduced in this chapter. In the following chapters this Use Case accompanies the problem solution descriptions. The Use Case is a small excerpt from a participatory field observation conducted while sailing from New Castle upon Tyne (United Kingdom) to Riga (Latvia) with a DNVGL classified S-Class bulk carrier between 06.-12.10.2014. Figure 27 shows the bulk carrier's front-row of the bridge during navigation towards the Skagerrak region.

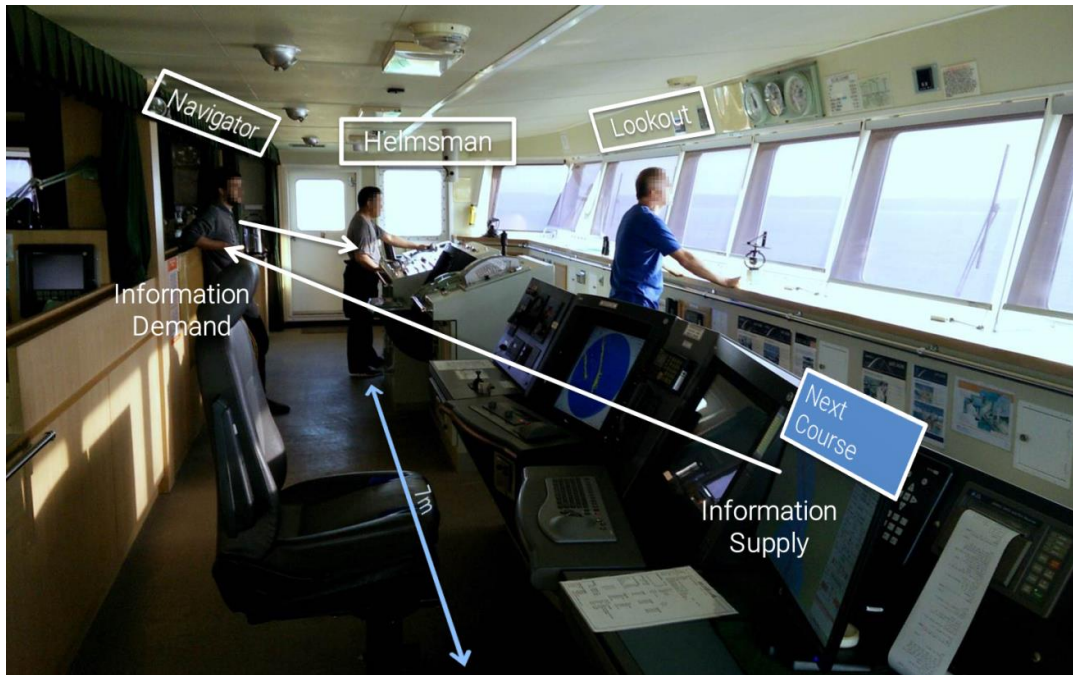

**Figure 27: Course change on a bulk carrier - the Next Course information element from the ECDIS is demanded by the Navigator, who supplies it to the Helmsman, who steers the rudder. Meanwhile, a Lookout is monitoring the sea for potential dangers.**

### **Bridge Equipment**

The ship bridge's front row is equipped on the left console (Figure 27, from back to front) with a manual helm/steering station, a panel for light decoration and alerts for water-protective doors, an X-Band Radar, a panel with onboard communication devices and the machine telegraph. The right (front) console is equipped with several equipment for track and heading control, an S-Band Radar, an ECDIS with INS functions, whose original monitor is defect, a backup Monitor (showing the ECDIS), NAVTEX, and AIS (not shown in the picture). An operator chair is positioned fixed in front of the original ECDIS monitor. In the front above the Lookout's head, a machine RPM indicator, rudder indicator, a clinometer and an echo sounder are positioned. Underneath, a sextant and binoculars can be found next to several posters with Master's standing orders. In the back-row (not in the picture), distress systems, mail systems, fax, weather routing, crew's organization systems are placed on the left part of the console. The back-right part of the console is a chart table with a GPS receiver, echo sounder, a fire alarm panel and shelves with rules, regulations, ship details, and various flags.

### **Crew Work Organization**

In this short excerpt of the long sail, the crew works together for navigating the ship. Due to heavy swell, the autopilot cannot keep track on its own. Thus, a Helmsman is ordered to steer



the ship on the manual helm, being tasked to keep a specific heading. The heading information is ordered by the Navigator and acknowledged by the Helmsman, who alters the rudder accordingly and informs the Navigator on arrival at the desired heading. To order the correct heading to the Helmsman, the Navigator perceives the *Next Course* information at the end of a leg (part of a route) from the ECDIS display. Simultaneously, the Lookout is monitoring the sea for potential dangers, which may affect the ship, f.i. cause a collision.

### **Observed Alterations in Crew Work Organization**

The bridge information distribution on the ship bridge equipment is static and not changed during this Use Case. In contrast, there was an (short) alteration to the crew work organization observed: At the beginning of the heavy swell, the Helmsman was absent and the Navigator was responsible to play the roles of Helmsman and Navigator in parallel. As indicated on Figure 27, this causes the crew member to manually steer and synchronously to perceive the *Next Course* from the ECDIS in around 7 meters distance. During heavy swell, overcoming this distance on volatile grounds, may take time in which the ship is disabled and adrift.

## **4.2 The Set Theoretical Concept of Information Supply and Demand**

An idea, which contributes to the baseline of this thesis' set theoretical concept of information supply and demand is the so-called information gap introduced by Endsley and Jones (Endsley & Jones 2011; Endsley 2000). Their concept describes the information gap as an inconsistency between data produced and information needed. There are various definitions and meanings on what data and what information are and how they differ. The data-information-knowledge-wisdom discussion gives an insight into that field (Fricke 2009; Rowley 2007). There data "has no meaning or value because it is without context and interpretation" (Rowley 2007). In contrast, information has a format, is structured and organized, has a meaning and a value feature (Rowley 2007). Since information has a meaning and value feature, the set theoretical concept uses the term "information supply" instead of "produced data". Furthermore, the term "information demand" is used instead of information need. This also corresponds to the concept of information elements of the DSA approach (chapter 2.3), where externally observable interactions are measured. Further, in DSA information elements describe concepts of information, which is adopted within the set theoretical concept.

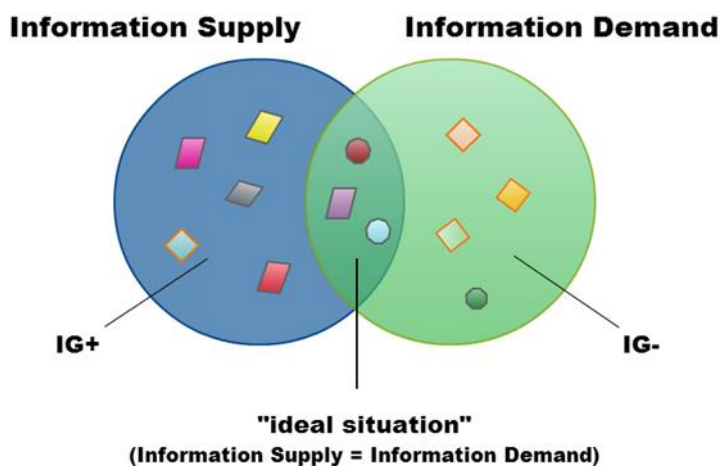

**Figure 28: The information gap model describes the relation between information supply and demand. Information supply and demand are two sets mapping to information elements.  $IG^+$  represents oversupply and  $IG^-$  the undersupply of information elements. In the ideal situation information supply and demand sets are equal.**

During task execution human and machine agents are demanding and supplying information. When two agents or artifacts supply and demand an information element with each other, then an SA Transaction has occurred. The basic concept of supply and demand facilitated in this approach is taken from business studies. In business studies' controlling a set theoretical concept of information supply, demand and requirements exists (Weber & Schäffer 2006). Within that concept information requirements describe all information which are necessary to the management e.g. for making a decision. An information demand is issued to fulfill the management's information requirements. The information demand describes information which is requested from the information supply. In the "ideal situation" the sets of required information, demanded information and supplied information overlap. (Weber & Schäffer 2006)

The set theoretical concept is inspired by Weber & Schäffer's concept and it is transferred to investigate gaps between information supply and demand between human and machine agents. The result is the information gap model depicted in Figure 28. In the model an information gap is defined mathematically by the two complements of the intersection of information supply and demand. This means that an information gap can have two characteristics: (1) supplied information is not demanded or (2) demanded information is not supplied. The former is also part of the previously stated definition of the information gap by Endsley. We call this part information gap plus ( $IG^+$ ), since there is more information available than demanded. The second part is called information gap minus ( $IG^-$ ), because there are less information available than demanded. This information gap definition is a fundamental part of

this set theoretical concept. In the ideal situation, information supply and demand are well-balanced.

### Formalization

To provide a sharp definition of the information gap model is formalized as follows: Information elements are globally defined with subsets for information supply and information demand set of information elements:

- $IE = \{ie_1, ie_2, \dots, ie_n\}$  describes a finite set of all information elements.
- $IS = \{sie_1, sie_2, \dots, sie_n\}$  describes a finite set of Information Supply, that is a subset of  $IE$  ( $IS \subseteq IE$ ), or quantified mapped as  $id: IS \rightarrow IE, x \mapsto x$ .
- $ID = \{die_1, die_2, \dots, die_n\}$  describes a finite set of Information Demand, that is a subset  $IE$  ( $ID \subseteq IE$ ), or quantified mapped as  $id: ID \rightarrow IE, x \mapsto x$ , too.

With set theory we define the following axioms:

- $IG^+ = IS - ID$  describes the information gap plus as information supply without information demand.
- $IG^- = ID - IS$  describes the information gap minus as information demand without information supply.
- $MS = IS \cap ID$  describes the matching situation between supply and demand as the intersection of information supply and demand.

As depicted in Figure 28, an “ideal situation” exists, if  $ID = IS$ , thus  $\forall x(x \in ID \Rightarrow x \in IS) \wedge \forall x(x \in IS \Rightarrow x \in ID)$ . With this set theoretical concept it is possible to deduce SA Transactions:

- $T_{SA} = \{t_{SA_1}, t_{SA_2}, \dots, t_{SA_n}\}$  describes a finite set of SA Transactions, where
- $\tau : T_{SA} \rightarrow \{A \subseteq IS \times ID \mid (x, y) \in A \Rightarrow x = y\}$  describes the mapping function of  $T_{SA}$  to information elements, that exist in  $IS$  and in  $ID$ .
- $\psi_{IS}(t_{SA_i}) := IS \text{ of } t_{SA_i}$  and  $\psi_{ID}(t_{SA_i}) := ID \text{ of } t_{SA_i}$  describe mapping functions for retrieval of  $IS$  and  $ID$  for a SA Transaction  $t_{SA_i} \in T_{SA}$ .

This is a difference to the DSA theoretical approach: In DSA, agents ( $a \in A$ ) are mapped with each other and the transaction is then mapped ( $\alpha$ ) to an information element ( $A = \{a_1, a_2, \dots, a_n\}, \tau : T_{SA} \rightarrow A \times A, \alpha: T_{SA} \rightarrow IE$ ). It is trivial, that the definition of  $T_{SA}$  as mapping between agents forces hard coupling over an information element. This thesis' concept maps

between *IS* and *ID*, and thus allows loose coupling between agents over information elements.

### **4.3 Sensomotoric Geometries for Transacting Information Supply and Demand**

But, how can information supply and demand be coupled in a physical world? With the DSA model this is not answered, since it is purely descriptive; based on observations, and thus does not provide an explanation about how agents physically interface to transact information elements. This raises an issue for assessing the fitness of information supply and demand, since an agent's senses may actually perceive and therefore transact more or less information elements, than those supplied by the agent or artifact being in transaction with in the real world. Issues can be:

- From an agent's position information demand may not be transacted due to impeded sensibility/perceivability (via any modality, e.g. vision system impedes vision of information from a display, auditive signal too quiet for ears/microphone, not being close enough to feel a vibrotactile device) or agent's information supply cannot be transacted over motoric input to other agents (via any modality, e.g. touch inputs are not possible, gestures are too small to be perceived by a gesture recognition system, speech is too quiet to be detected by a microphone).
- A human agent may be in a position that allows transaction with multiple other agents. Meaning, other agents' supplied information may be sensed/perceived, during transaction with only one agent (again via any modality, e.g. visual perception of multiple displays, auditive perception of multiple signals, etc.) or multiple agents demanding for information elements are transacting information elements in course of an agent's intended motoric input to solely one other agent. The latter case corresponds to broadcast/spread modalities, which can be perceived by more than one agent, such as voice or gestures.

To encounter both problems in this approach, the concept of sensomotoric geometries is introduced for agents (and artifacts).

A sensomotoric geometry is an area or volume in space, that represents transactability of information supply to, or information demand from, agents and artifacts, who are colliding with (or are inside of) it in a mutual space. Sensomotoric geometries are a generalized and

abstracted structure, representing humans' and machines' limited ability of sensing information elements in their environment and simultaneously describing their limited stimuli-producing sources/motors (e.g. voice) for these senses.

The concept is used in this thesis' method during simulation to adjust parameters, such as position and posture of agents, to "drive" the agents into a state that allows for transactability of information elements. Figure 29 shows sensomotoric information supply and demand geometries of a human agent (green) and a machine agent (blue) for transacting information elements via vision.

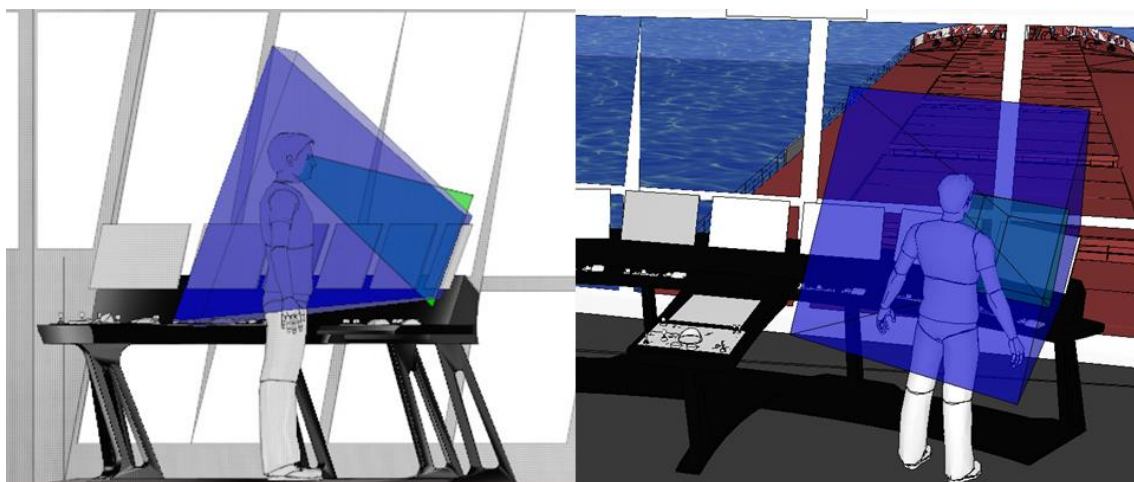

**Figure 29: Sensomotoric Geometries for Transacting Information Supply and Demand between a Human and a Machine Agent over Vision on a Ship Bridge**

Humans' sensomotoric requirements for vision, audition and touch senses are described within nowadays design guidelines (see chapter 2.2). From there, sensomotoric geometries for information demand transactability for vision can be taken: The Field of View description, providing the Preferred Viewing Area as  $15^\circ$  angle, which can be represented as geometry. Any agent, providing stimuli for human vision, can be attributed with viewing geometries as well, which define in whose space their information supply is visible. The range of that geometry describes a threshold for transactability. In auditory sensing, this is similar, since spatial auditive sensibility is primarily driven by the sound sources' properties, such as sound pressure and frequency (Blauert 1997). Directedness and spread of sound at a defined threshold limit for agents' senses is modelled as geometry as well. For touch, sensomotoric geometries can be created for reaching areas (see chapter 2.2.4), which encode thresholds for touching, whereas touchable geometries are describable e.g. as surfaces.

## Model Formalization

The basic sensomotoric geometries for transacting information elements are formalized as follows. For information supply where properties describe the different modalities' geometries:

- $ISS = \{IS_1, IS_2, \dots, IS_n\}$ , describes a finite set of all information supply sets ( $IS$ ),
- $P_{IS_i} = \{p_{IS_{i_1}}, p_{IS_{i_2}}, \dots, p_{IS_{i_n}}\}$ , is a finite set of properties for an information supply set  $IS_i$ .  $p_{IS_{i_n}}$  is an ordered pair that defines a name and value (e.g.  $(name, "Master")$ ).  $\forall IS_i \in ISS \exists P_{IS_i}$ , every agent has a set of properties. The function  $p(IS_i) = P_{IS_i}$ , allows lookup of property sets.
- $\forall IS_i \in ISS \exists p_{IS_{i_1}}, p_{IS_{i_2}}, p_{IS_{i_3}} \in P_{IS_i}: p_{IS_{i_1}} = (visual_{geometry}, G_{IS_{visual}}) \wedge p_{IS_{i_2}} = (auditive_{geometry}, G_{IS_{auditive}}) \wedge p_{IS_{i_3}} = (touch_{geometry}, G_{IS_{touch}})$  every machine agent has a  $visual_{geometry}$ , a  $auditive_{geometry}$  and a  $touch_{geometry}$  as property that is defining as an undirected graph, e.g.  $G_{IS_{visual}} = (V, E)$ .

For information demand where modalities' geometries are properties of the information demand set as well:

- $IDS = \{ID_1, ID_2, \dots, ID_n\}$ , describes a finite set of all information demand sets ( $ID$ ),
- $P_{ID_i} = \{p_{ID_{i_1}}, p_{ID_{i_2}}, \dots, p_{ID_{i_n}}\}$ , is a finite set of properties for an information supply set  $ID_i$ .  $p_{ID_{i_n}}$  is an ordered pair, that defines a name and value (e.g.  $(name, "Master")$ ).  $\forall ID_i \in IDS \exists P_{ID_i}$ , every agent has a set of properties. The function  $p(ID_i) = P_{ID_i}$ , allows lookup of property sets.
- $\forall ID_i \in IDS \exists p_{ID_{i_1}}, p_{ID_{i_2}}, p_{ID_{i_3}} \in P_{ID_i}: p_{ID_{i_1}} = (visual_{geometry}, G_{ID_{visual}}) \wedge p_{ID_{i_2}} = (auditive_{geometry}, G_{ID_{auditive}}) \wedge p_{ID_{i_3}} = (touch_{geometry}, G_{ID_{touch}})$  every machine agent has a  $visual_{geometry}$ , a  $auditive_{geometry}$  and a  $touch_{geometry}$  as property that is defining as an undirected graph, e.g.  $G_{ID_{visual}} = (V, E)$ .

This formalization defines existence of sensomotoric geometries for sets of information supply and demand. Of course, geometries can vary for each information element in reality, e.g. different displays or display modes may provide information elements with varying font sizes. It is then sensible to consider separation of these  $IS$  and/or  $ID$ . For  $IS$ 's and  $ID$ 's a generalized mapping function predicate is defined that allows retrieval of a modality's geometry:

$geometry_{mod}(IS_i) = y$ , where  $(x, y) = p_{IS_{i_n}} \in P_{IS_i} \wedge x = mod$  and  $geometry_{mod}(ID_i) = y$ , where  $(x, y) = p_{ID_{i_n}} \in P_{ID_i} \wedge x = mod$ , where  $mod$  is the modality (e.g. visual, auditive, touch) and  $p_{IS_{i_n}}$  and  $p_{ID_{i_n}}$  are the sensomotoric geometries for the  $IS$  or  $ID$  respectively and  $n \in \{1, 2, \dots, m\}$ .

For calculating collisions of sensomotoric geometry with an agent, it is necessary that agents have a point or geometry in space that is used to collide with. For this concept geometry retrieval predicates are defined that map from information supply and demand sets to its agent's collision geometry in space:

$$\begin{aligned} bodygeometry(IS_j) = y, \text{ where } (geometry, y) = p_{A_{in}} \\ \in P_{A_i} \wedge (information_{states}, (E, R, \Gamma)) = p_{A_{in}} \in P_{A_i} \wedge IS_j \subseteq E \end{aligned}$$

$$\begin{aligned} bodygeometry(ID_j) = y, \text{ where } (geometry, y) = p_{A_{in}} \\ \in P_{A_i} \wedge (information_{states}, (E, R, \Gamma)) = p_{A_{in}} \in P_{A_i} \wedge ID_j \subseteq E \end{aligned}$$

There *Agents* is the finite set of all agents, and  $p_{A_i}$  is a property of an agent, that is an ordered pair, that defines a name and value (e.g.  $(information_{supply}, IS)$ ;  $\forall A_i \in Agents : P_{A_n} \in A_n$ , where  $P_{A_n}$  is a finite set of properties of an agent. A detailed description of *Agents* is given in chapter 4.5.1.

### Collision Formalization

So, the calculation of geometry collision is possible with the spatial predicates of the Nine-Intersection Model (9IM) (Egenhofer 1989; Egenhofer & Herring 1990; Egenhofer & Franzosa 1991). 9IM describes topological relationships between two geometries. It allows to analyze and describe relationships between two points, lines, regions and bodies (3D) (Borrmann et al. 2006). This is done by describing intersections of the *interior*, *boundary* and *exterior* of two objects/geometries in an  $3 \times 3$ -intersection matrix (Egenhofer 1989; Egenhofer & Herring 1990; Egenhofer & Franzosa 1991). The 9IM for Euclidean space  $R$  is defined with the objects  $A$  and  $B$  and notations:

$$R_{9IM}(A, B) = \begin{pmatrix} A^\circ \cap B^\circ & A^\circ \cap \partial B & A^\circ \cap B^- \\ \partial A \cap B^\circ & \partial A \cap \partial B & \partial A \cap B^- \\ A^- \cap B^\circ & A^- \cap \partial B & A^- \cap B^- \end{pmatrix}$$

- The *boundary* of an object  $\lambda$ , noted  $\partial\lambda$ , is defined:
  - As  $\lambda$  is a zero-dimensioned finite set of isolated points, then the boundary is empty.
  - If  $\lambda$  is a one-dimensioned set of points, then the boundary is the set of its end-points.

- If  $\lambda$  is a two-dimensional set of points, then the boundary is defined by bordering lines of the region.
- Then the *interior* of an object  $\lambda$ , noted  $\lambda^\circ$ , is defined as  $\lambda - \partial\lambda$ .
- The *closure* of an object  $\lambda$ , noted  $\bar{\lambda}$ , is defined as  $\lambda \cup \partial\lambda$ .
- The *exterior* of an object  $\lambda$ , noted  $\lambda^-$ , is defined as  $R^n - \bar{\lambda}$ , where  $R^n$  is the n-dimensional Euclidean space.
- An object  $\lambda$  is called *closed*, when  $\lambda = \bar{\lambda}$ .

In 9IM intersections result in an empty set ( $\emptyset$ ) or a non-empty set ( $\neg\emptyset$ ) of points. These symbols are used together with a wildcard (\*) to describe spatial predicates with masks. The spatial predicates necessary for this approach are the *touches* and *contains* predicate, which are defined with their sets of masks in the following:

$$touches(A, B) = \left\{ \begin{bmatrix} F & T & * \\ * & * & * \\ * & * & * \end{bmatrix}, \begin{bmatrix} F & * & * \\ T & * & * \\ * & * & * \end{bmatrix}, \begin{bmatrix} F & * & * \\ * & T & * \\ * & * & * \end{bmatrix} \right\}$$

$$contains(A, B) = \left\{ \begin{bmatrix} T & * & * \\ * & * & * \\ F & F & * \end{bmatrix}, \begin{bmatrix} T & * & F \\ * & * & F \\ * & * & * \end{bmatrix} \right\}$$

The *collides* predicate is defined as follows:

$$collides(A, B) = touches(A, B) \vee contains(A, B)$$

The predicate is used to finally formalize transactability for a common modality with sensomotoric geometries:

$$\begin{aligned} &transactability_{mod}(IS, ID) \\ &= collides \left( \begin{matrix} geometry_{mod}(IS), \\ bodygeometry(ID) \end{matrix} \right) \wedge collides \left( \begin{matrix} geometry_{mod}(ID), \\ bodygeometry(IS) \end{matrix} \right) \end{aligned}$$

## 4.4 Generalized Spatio-Temporal Reasoning Model for Information Supply and Demand

The third advance provided with this thesis is a *spatio-temporal reasoning model*, which enables to derive qualitative assertions over supply and demand of information elements. The reasoning model is a variant of the Life and Motion Configuration (LMC) calculus (Hallot & Billen 2008b). Where the originating LMC calculus deals with the concepts of existence and presence of physical objects, this thesis' variant deals with the concepts of *existence* and *transactability* of information elements in space and time. As a spatio-temporal calculus, this thesis' LMC calculus aims for spatio-temporal analysis and reasoning to process data



efficiently, to enable processing of a vast amount of data. Therefore the LMC variant describes information elements in time and space, and describes spatio-temporal relationships between multiple information elements.

In the following, first spatio-temporal states considering the concepts of *existence* and *transactability* are introduced. Second, the formalization of LMCs from Spatio-Temporal Histories of (Muller 2002) is shown.

#### 4.4.1 Spatio-Temporal States

A LMC is defined as a temporally ordered set of spatio-temporal states. A spatio-temporal state describes the relation of two points at one point in time. Thus a LMC set's spatio-temporal states allow encoding the spatial change of each point as a line object.

Here, the states describe the relationships *existence* and *transactability* of supply ( $A$ ) and demand ( $B$ ) of an information element. The *existing relationship* has the underlying concept, that there is a period of time, where a supply or demand of an information element has not yet existed, and one period, where the supply or demand does not exist anymore. The underlying belief is that a supply or demand that stopped to exist does not revive. With the existence relationship there are four possible states at a given time:  $A$  and  $B$  do not exist  $\{\neg A \wedge \neg B\}$ , only  $A$  or  $B$  exist  $\{\exists A \wedge \neg B\}$ ,  $\{\neg A \wedge \exists B\}$ , and  $A$  and  $B$  exist  $\{\exists A \wedge \exists B\}$ .

When a demand or supply for an information element is existent, then this demand/supply can be *transactable* or not. This is a difference to sensomotoric geometries' transactability predicate which corresponds to both supply and demand jointly. Here, the *transactable* predicate is unary and can be assigned separately to supply or demand. The *transactable relationship* has the underlying concept that an information element's supply can be ready for transaction, independently from the readiness for transaction of a demand of an information element. Both independent cases can be expressed with the formulae for transactable information element supply

$$\text{collides} \left( \begin{matrix} \text{geometry}_{mod}(IS), \\ \text{bodygeometry}(ID) \end{matrix} \right) \wedge \neg \text{collides} \left( \begin{matrix} \text{geometry}_{mod}(ID), \\ \text{bodygeometry}(IS) \end{matrix} \right)$$

and formulae for transactable information element demand

$$\neg \text{collides} \left( \begin{matrix} \text{geometry}_{mod}(IS), \\ \text{bodygeometry}(ID) \end{matrix} \right) \wedge \text{collides} \left( \begin{matrix} \text{geometry}_{mod}(ID), \\ \text{bodygeometry}(IS) \end{matrix} \right).$$

This separating perspective on transactability allows to formally expressing that a human agent's information demand or supply was not transactable, due to a) non-

alignment/disorientation of sensomotoric geometries or b) insufficiencies in transactional memory. Where a) considers physical occurrence of agents, b) considers lacks in reliance that “people have on other people (Wegner 1986) and machines (Sparrow et al. 2011) to remember for them” (Stanton et al. 2014) according to the theory of “transactional memory” (Wegner 1986). Of course, machine agents’ demand or supply transactable relationship can be expressed analogously. E.g. a display’s font size is too small (a)) or the display mode needs to be switched to transact information elements (b)).

To express *transactability* of an information element supply or demand the LMC notation for visibility is ‘overwritten’ and called the *transactability-operator* notated with brackets ((, )). Again four states may occur with/without *transactability*:  $A$  and  $B$  are both not *transactable*  $\{(A) \wedge (B)\}$ , one of them is not *transactable*  $\{(A) \wedge B\}, \{A \wedge (B)\}$ , or both are *transactable*  $\{A \wedge B\}$ . Clearly, the *transactability* concept is depending on the *existence* of an information element instance/object, hence an information element cannot be *transactable* when it does not exist. With the concept of *existence* only temporality is considered. With *transactability* the spatiality is considered, which is different to Hallot and Billen’s presence concept that does not cater for spatiality. When supply and demand of information elements are transactable (hence are also existent), their fitness states can be described. Since LMCs consider points, it is possible to describe the fitness relationship as *equal* or *disjoint*: Thus  $A$  and  $B$  are either equal  $\{e\}$ , or disjoint  $\{d\}$ . The combination of the existence, transactability and the fitness of two information elements (see chapter 4.3) is shown with the decision tree in Figure 30. The notations of the states are depicted in blue frames and from a jointly exhaustive and pairwise disjoint set (JEPD set).

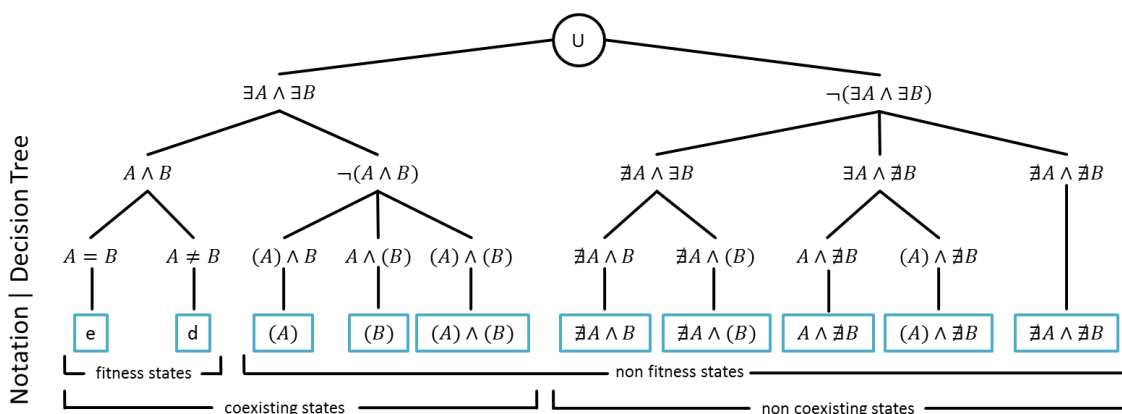

**Figure 30: Decision tree and notation of spatio-temporal states for Life and Motion Configurations for existence and transactability adopted from (Hallot & Billen 2008a)**

### 4.4.2 Formalization of Life and Motion Configurations

The two-point description of spatio-temporal states is referencing one point in time. By putting them into a temporally ordered set of spatio-temporal states, the LMC is assimilated, which encodes the spatial change of multiple points as a line object. The process to setup LMCs is the following and depicted on Figure 31:

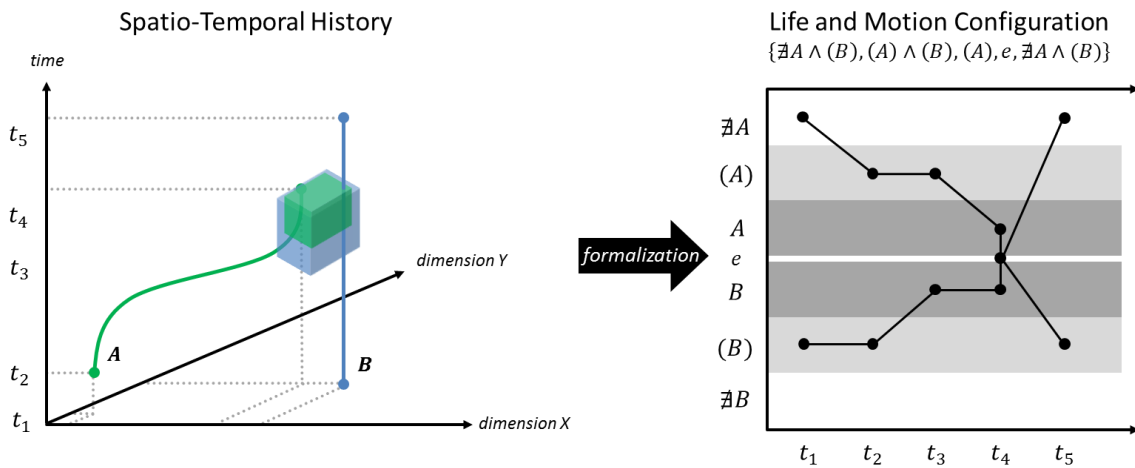

**Figure 31: Formalization of a Spatio-Temporal History into the Life and Motion Configuration variant. Cubes indicate sensomotoric geometries ready for transaction of information element A (green) and B (blue) in a 3D temporal space. The LMC representation shows the evolution of spatio-temporal states over time. In  $t_4$  information elements are transactable.**

First, the spatio-temporal states are elicited from *spatio-temporal histories*, which can be expressed in a *2D temporal space* (Hallot & Billen 2008c). The approach of *spatio-temporal histories* is postulated by Muller (Muller 2002), who envisions spatio-temporal histories of objects as primitive entities. His theory introduces temporal and topological relations for the entities and classes of spatial changes. This allows analyzing spatio-temporal histories of shapes. Therefore, the Region Connection Calculus (RCC (Egenhofer & Mark 1995)) was extended with a binary primitive of temporal connection denoted  $\bowtie$ , that connects two objects or regions in the temporal dimension, e.g. blueship  $\bowtie$  redship denotes that the two ships are existent at the same point in time. Further,  $<$  is used as a primitive that denotes, that  $x$  exists before  $y$  ( $x < y$ , analogue to Allen’s *before* operand (Allen 1983)). To link these temporal primitive Muller’s theory introduces that any spatio-temporal connection must imply a temporal connection: Then for every relation  $C$  in RCC the following shall be true:  $C(x, y) \rightarrow x \bowtie y$ . To reflect changes of relations over time the theory introduces temporal parts, which are denoted as temporal slice  $TS$ . Any (primitive) entity can have a  $TS$ . “A temporal slice  $x$  is a part of an entity  $y$  such that any part of  $y$  that is temporally included in  $x$  is a part of

$x (TS(x, y) \triangleq P(x, y) \wedge ((P(z, y) \wedge z \subseteq_t x) \rightarrow P(z, x)))$ , where  $P(x, y)$  defines that  $x$  is a part of  $y$ , and  $x \subseteq_t y$  defines the temporal inclusion of  $x$  in the interval of  $y$ ” (Muller 2002).

Secondly, LMCs formalize the spatio-temporal histories for points in time, which can be visually represented on a *2D degenerated temporal space*. That degenerated temporal space’s axes represent time and transactability. The transactability axis is degenerated to the representation of seven positions to express existence, transactability, and equality between two polylines, analogue to Hallot’s thesis (Hallot 2012, p.172).

To elicit a spatio-temporal states from spatio-temporal histories, temporal slices are considered in which information element’s geometries (body and sensomotoric geometries) can be described with 9IM’s predicates *equals*, *disjoint*, *touches*, *contains*, *covers*, *intersects*, *within*, and *coveredBy* (see chapter 4.3 on sensomotoric geometries). Transactability can be assigned with the functions described in chapter 4.2 and chapter 4.3.

Within the following three chapters the three step method, consisting of modelling, simulation and analysis, is described.

## **4.5 Modelling - Creating an Integrated Model for Process Execution**

The first step, to assess the spatio-temporal information supply and demand fitness, is to create an Integrated Model that describes the collaborative process execution in a work environment. Figure 32 depicts the modelling part of the method, which is applied to create such an Integrated Model. The modelling method is split into two sub-processes. During *Integrated Model Elicitation* (1), an initial Integrated Model is set up, in which collaborative processes are not linked to the Spatial Model. During *Model Execution Planning & Verification* (2), the models are linked over SA Transactions and the overall model is then verified.

In the following, both sub-processes are defined in detail with underlying concepts, inputs to the processes and outputs of the processes.

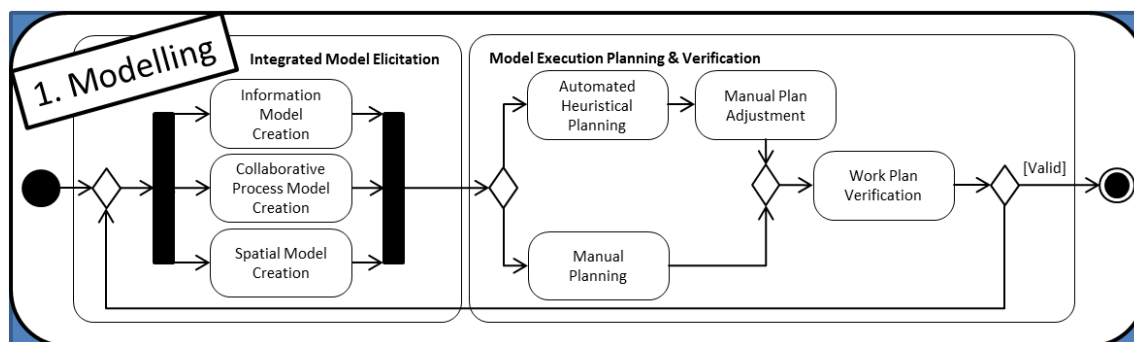

**Figure 32: Step 1 - Modelling - Creating an Integrated Model for Process Execution**

#### 4.5.1 Integrated Model Elicitation

The elicitation of an Integrated Model is the initial step of this method. The sub-chapters describe the inputs to this step, the process of setting up partial models to the Integrated Model and the outputs of this step.

##### 4.5.1.1 Input

The method is embedded into the human-centered design process (see chapter 2.1) under its Activity 4 as an inspection-based evaluation approach for *Designing the Interaction* and *Designing the User Interface*. Therefore results of previous Activities are taken as input to the method: The context of use is required to describe users, their roles, tasks and the environment(s) of the desired system. For creation of such a description the full canon of process elicitation methods can be facilitated. Exemplary methods for process elicitation are described with the EAST and WESTT methods, but document research, observation, interviews, workshops, surveys or simulator studies (Balzert et al. 2011; Denker et al. 2015) may provide contents for the context of use description as well. A sufficiency for model elicitation with this method is reached, if information elements, in sense of DSA, can be derived for the user's tasks. A description, such as the crew work organization description in chapter 4.1 may be sufficient.

Further, the system being designed during *Designing the User Interface* is required as input to the method. The system descriptions could consist of technical drawings and layouts of the work environment, equipment such as displays and control panels, which are categorized as artifacts in DSA, shall be provided with the technical descriptions containing their positioning, their information elements, and information on accessibility. A bridge layout of the use case's ship is shown in Figure 33. Accessibility of an equipment is considered as a human's ability to

supply or demand information via a specified modality. Equipment may be a “multifunctional”, meaning that its states can change/can be changed. The multifunctionalities w.r.t. changes in accessibility to information elements need to be described as well.

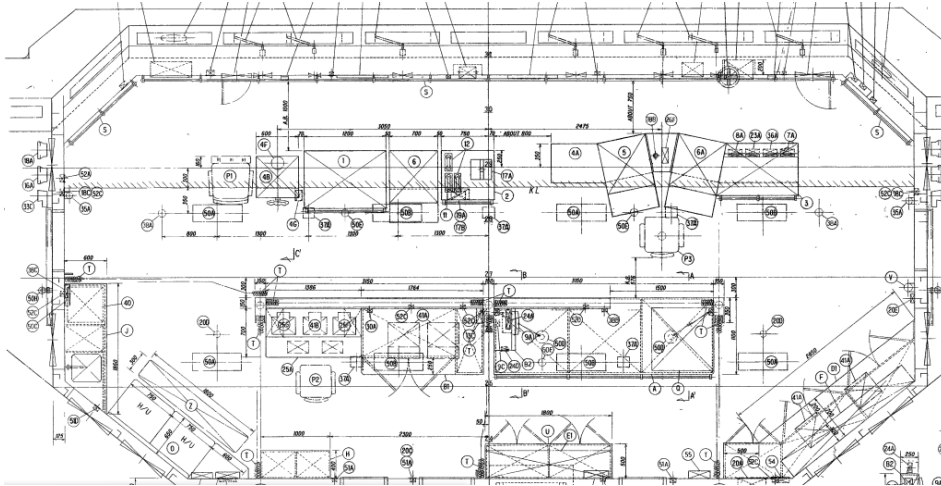

**Figure 33: Technical drawing of Use Case ship's bridge layout**

*Designing the Interaction* can be done abstractly with this thesis' method, or may be defined in other design activities. *Designing the Interaction* is treated with the *Model Execution Planning & Verification* in chapter 4.5.2.

#### **4.5.1.2 Process**

Based on the inputs, an Integrated Model is set up, which consists of an Information Model (1), a Collaborative Process Model (2) and a Spatial Model (3). Figure 34 symbolizes the Integrated Model as a triangle consisting of connected models 1-3, in a nautical scenario. The *Information Model* consists of information elements. The connection between *Information Model* and *Collaborative Process Model* entities is called the *Human Information Distribution*, which is the abstract term for the maritime crew work organization. The connection between *Information Model* and *Spatial Model* entities is called *Machine Information Distribution*, which is the maritime *Bridge Information Distribution*. The connection between *Spatial Model* and *Collaborative Process Model* entities forms the *Resource Management*, which is the generalized surrogate for *Bridge Resource Management*. For illustrational purposes maritime model instances are depicted in Figure 34.

In the remainder of this sub-chapter, the models are formally described, which allows to deduce how the models are set up in detail.

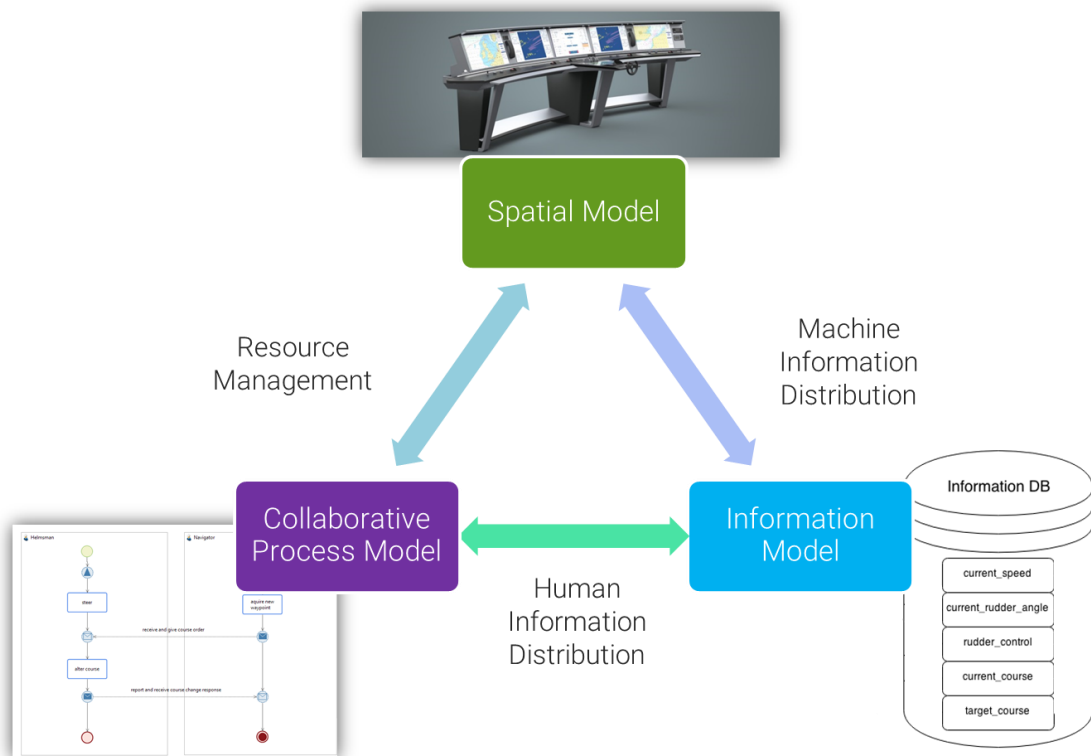

**Figure 34: The Integrated Model Triangle consists of an Information Model, a Collaborative Process Model and a Spatial Model. Here, instances of these models are depicted for a nautical scenario.**

#### 4.5.1.2.1 Information Model Creation

Information Elements are entities that describe information conceptually in DSA. Formally the Information Model is a simple finite set of information elements:

- $IE = \{ie_1, ie_2, \dots, ie_n\}$  describes a finite set of information elements, similarly to the overall set theoretical concept of this approach (see chapter 4.2).

Based on the context of use described with the Integrated Model elicitation input (chapter 4.5.2.1) the  $IE$  set is created. Therefore, all information concepts are gathered from the context of use description that is exchanged between the agents and artifacts of a system. E.g. in the observation described with the use case (chapter 4.1), it is stated that the Helmsman is tasked to steer the ship. As in DSA analyses methods, text analyses may be applied to the context of use descriptions, to gather information elements as in EAST and WESTT. Afterwards, it is sensible to conduct a subject matter expert (SME) to verify, that the information elements meet the correct level of detail.

## Use Case

In the quoted example, an information element “steer” would be probably insufficient, since the task of steering requires the helmsman f.i. to supply rudder control and to demand the current rudder angle and heading. A resulting Information Model would then be defined as  $IE = \{rudder_{control}, rudder_{angle}, heading, next\_course\}$ .

### 4.5.1.2.2 Collaborative Process Model Creation

As shown with the related work, EAST and WESTT apply graph structures in form of UML sequence diagrams and (propositional) networks to express the temporal order of work execution. In this approach these structures are described formally. The formalization is integrated with a formal description of a Spatial Model. The aim is here to provide a clear definition of the Integrated Model’s aspects.

UML models, such as Sequence Diagrams, can be formalized as multi-graphs (Kagdi et al. 2005). According to Kagdi et al., a model  $M$  can be described as a directed multi-graph  $M = (E, R, \Gamma)$  that consists of

- $E = \{e_1, e_2, \dots, e_n\}$ , a finite set of elements,
- $R = \{r_1, r_2, \dots, r_m\}$ , a finite set of relationships, and
- $\Gamma: R \rightarrow E \times E$ , a function that maps the relationships in  $R$  directed between elements in  $E$ .

Properties can be attributed to the elements, and relations analogous, here definitions of elements’ properties is shown:

- $P_{e_i} = \{p_{e_{i1}}, p_{e_{i2}}, \dots, p_{e_{in}}\}$ , is a finite set of properties for an element  $e_i$ .
- $p_{e_{in}}$  is an ordered pair, that defines a name and value (e.g.  $(name, "steer")$ ).
- $\forall e_n \in E : P_{e_n} \in e_n$ , every element has a set of properties.

To allow for description of multiple agents, the multi-graph model is simply divided into subsets for agents, thus a submodel  $M_{A_i} \subseteq M$  is defined by as  $M_{A_i} = (E_{A_i}, R_{A_i}, \Gamma_{A_i})$  as elements, relations and mappings for a defined agent  $A_i$ . The sum of all agent-based sub models ( $\bigcup_{i=0}^n M_{A_i} = M$ ) constructs the whole multi-graph  $M$ . On this and Kagdi et al.’s model bases, the following disjoint subsets to the sets of elements ( $E$ ) and relations ( $R$ ) are introduced to describe both task and team work (as conceptually separated in (Salas et al. 2008)):



- $E_{A_i Task} \subseteq E_{A_i}$ , is the subset of task elements of an agent that describe atomic task work. E.g. execution of the task *steering*.
- $E_{A_i Team} \subseteq E_{A_i}$ , is the subset of team work elements that are describing atomic team work of an agent. E.g. sending a vocal message *report next course*.
- $R_{A_i Sequential} \subseteq R_{A_i}$ , defines the subset of relationships, that exist between elements of  $E_{A_i}$  only ( $\Gamma_{A_i}: R_{A_i Sequential} \rightarrow E_{A_i} \times E_{A_i}$ ). These directed relationships describe the temporal execution order between all elements of an agent in  $E_{A_i}$ .
- $R_{A_i Synchronous} \subseteq R_{A_i}$ , defines a subset of relationships, that exist between team work elements of an agent  $A_i$  and  $A_j$ :  $\Gamma_{A_i}: R_{A_i Synchronous} \rightarrow E_{A_i Team} \times E_{A_j Team}$ . This subset's elements can be seen as synchronization points in time, since both agents are interacting with each other.

### Human Information Distribution

The successive step is to integrate the temporalized multi-graph for collaborative processes with the information supply and demand formalization from chapter 4.2 and the Information Model. This is done by giving every element in the Collaborative Process Model two properties. One property for information supply as well as one property for information demand:

- $\forall e_i \in E \exists p_{e_{in}} \in P_{e_i}: p_{e_{in}} = (information_{supply}, IS)$ , asserts that every element in  $E$  has a property with the name *information<sub>supply</sub>* that has an information supply set as value (*IS*).
- $\forall e_i \in E \exists p_{e_{in}} \in P_{e_i}: p_{e_{in}} = (information_{demand}, ID)$ , asserts that every element in  $E$  has a property with the name *information<sub>demand</sub>* that has an information demand set as value (*ID*).
- $p(e_i) = P_{e_i}$ , defines the function that allows retrieval of the property set of  $e_i$ .

### Use Case

From the use case descriptions, which are part of the context of use, users, their roles and tasks are deductible. Hence, the Collaborative Process Model can be created. The model consists of the models for agents  $M = \{Navigator, Helmsman, Lookout\}$ .

For the Navigator the elements are  $E_{Navigator_{Task}} = \{read\_course\}$ ,  $E_{Navigator_{Team}} = \{command\_course\_change\}$ , and sequential relations are defined  $R_{Navigator_{Sequential}} = \{(read\_course, command\_course\_change)\}$ .

For the Helmsman the elements are  $E_{Helmsman_{Team}} = \{receive\_course\_command\}$ ,  $E_{Helmsman_{Task}} = \{steer\}$ , and sequential relations are defined  $R_{Helmsman_{Sequential}} = \{(receive\_course\_command, steer)\}$ .

Commanding and receiving the course change is defined as  $R_{Navigator_{Synchronous}} = \{(command\_course\_change, receive\_course\_command)\}$ . The Lookout is neglected here.

For the Navigators task element *read\_course* a property set  $P_{read\_course}$  is created, that is defined:  $P_{read\_course} = \{(information_{supply}, \emptyset), (information_{demand}, \{next\_course\})\}$ . Similar property sets are created setting up the supplied and demanded information elements, for other elements:  $P_{command\_course\_change} = \{(information_{supply}, \{next\_course\}), (information_{demand}, \emptyset)\}$ ,  $P_{receive\_course\_command} = \{(information_{supply}, \{next\_course\}), (information_{demand}, \emptyset)\}$ , and  $P_{steer} = \{(information_{supply}, \{rudder_{control}\}), (information_{demand}, \{rudder_{angle}, heading\})\}$ .

#### 4.5.1.2.3 Spatial Model

For spatial modelling distribution of information in a space, the space must be defined. This is done on the basis of the designed system's description. As defined with modelling inputs, layouts and technical descriptions about information elements are sufficient. There exist various kinds of spaces in different disciplines, such as mathematics, physics, geography, psychology and even philosophy. In this approach, the mathematical space model of Euclid is applied to model the physical space of a working environment. Euclidean space is often called *real coordinate space* and is written  $R^n$ . It is called "real", since its points in space are described with real numbers. The space  $R^n$  is  $n$ -dimensional, thus  $R^2$  describes a two-dimensional (planar), and  $R^3$  a three-dimensional space.  $R^n$  is a set of all  $n$ -tuples of real numbers ( $W = \{w_1, w_2, \dots, w_n\}, W \in R^n$ ). A Cartesian coordinate system can be used to specify points in an  $R^n$ , if the working environment is not highly influenced by the curvature of its surroundings (e.g. earth). In the following a set theoretical model is build up, that allows for distribution of information on agents in a Euclidean space:

- $S^n \subset R^n$ , a space subset ( $S$ ), that is part of the  $n$ -dimensional Euclidean space set,
- $Agents = \{A_1, A_2, \dots, A_n\}$ , describes a finite set of agents,

- $Agents_H \subseteq Agents$ ,  $Agents_M \subseteq Agents$ , describe the subsets of human and machine agents in the sense of DSA Theory, but in the sense of physical representations. Therefore,
- $P_{A_i} = \{p_{A_{i1}}, p_{A_{i2}}, \dots, p_{A_{in}}\}$ , is a finite set of properties for an agent  $A_i$ .  $p_{A_{in}}$  is an ordered pair, that defines a name and value (e.g.  $(name, "Master")$ ).  $\forall A_n \in Agents : P_{A_n} \in A_n$ , every agent has a set of properties. Again, the function  $p(A_i) = P_{A_i}$ , allows lookup of property sets.
- $\forall A \in Agents_M \exists p_{A_{in}} \in P_{A_i} : p_{A_{in}} = (information_{states}, IStates)$ , every machine agent has a property  $information_{states}$ , that defines another multi-graph  $IStates = (E_{states}, R_{states}, \Gamma_{states})$ . There,  $E_{states} = \{e_{state_1}, e_{state_2}, \dots, e_{state_n}\}$  is a finite set of so-called information states.  $R_{states} = \{r_{state_1}, r_{state_2}, \dots, r_{state_n}\}$  is a finite set of relations between elements of  $E_{states}$  and represent fixed transitions between information states. These relations are mapped via the function  $\Gamma_{states} : R_{states} \rightarrow E_{states} \times E_{states}$ .
  - $P_{e_{state_i}} = \{p_{e_{state_1}}, p_{e_{state_2}}, \dots, p_{e_{state_n}}\}$ , is a finite set of properties for an information state  $e_{state_n}$ .  $p_{e_{state_n}}$  is an ordered pair, that defines a name and value (e.g.  $(name, "menu")$ ).  $\forall e_{state_n} \in E_{states} : P_{e_{state_i}} \in e_{state_n}$ , every information state has a set of properties. Again, the function  $p(e_{state_i}) = P_{e_{state_i}}$ , allows lookup of property sets. These are properties for information supply and demand:
    - $\forall e_{state_n} \in E_{states} \exists p_{e_{state_n}} \in P_{e_{state_i}} : p_{e_{state_n}} = (information_{supply}, IS)$ , asserts that every information state has a property with the name  $information_{supply}$ , that has an information supply set as value ( $IS$ , see chapter 4.2).
    - $\forall e_{state_n} \in E_{states} \exists p_{e_{state_n}} \in P_{e_{state_i}} : p_{e_{state_n}} = (information_{demand}, ID)$ , asserts that every information state has a property with the name  $information_{demand}$ , that has an information demand set as value ( $ID$ , see chapter 4.2).
- $\forall A \in Agents_M \exists p_{A_{in}} \in P_{A_i} : p_{A_{in}} = (current_{state}, e_{state_1} \in E_{states})$ , is a property that defines a current information state. Meaning which information supply and demand is currently presented by a machine agent.

- $\forall A \in Agents_H \exists p_{A_{in}} \in P_{A_i}: p_{A_{in}} = (taskmodel, M_{A_i})$ , it is ascertained that every human agent has a task model that describes the tasks to be executed.
- $\forall A \in Agents \exists p_{A_{in}} \in P_{A_i}: p_{A_{in}} = (position, x \in S^n)$ , every agent has a property that describes the agent's position as point in the space  $S^n$ .
- $\forall A \in Agents \exists p_{A_{in}} \in P_{A_i}: p_{A_{in}} = (geometry, G)$ , every agent has a property, that describes the agent's physical geometry as an undirected graph ( $G = (V, E)$ ), that consists of a set of vertices ( $V$ ) and edges ( $E$ ). Again, vertices are in  $S^n$ .

### Use Case

The human agents and the machine agents are defined. In this use case only Navigator, Lookout, ECDIS and Helm is considered:  $Agents_H = \{A_{Navigator}, A_{Helmsman}\}$ ,  $Agents_M = \{A_{ECDIS}, A_{Helm}\}$ . The information states of the machine agents are defined. Since both ECDIS and Helm have only one state, they are analogously defined and thus only the definition of ECDIS is shown in the following:

$$P_{A_{ECDIS}} = \left\{ \left( information_{states}, (\{e_{ECDIS_{Screen}}\}, \emptyset, \Gamma) \right), (current_{state}, e_{ECDIS_{Screen}}), \right. \\ \left. (position, (1,1,1)), (geometry, G_{ECDIS}) \right\}, \quad \text{where} \quad P_{e_{ECDIS_{Screen}}} = \left\{ (information_{supply}, \{next_{course}\}), (information_{demand}, \emptyset) \right\}$$

and geometries definition is trivial and thus neglected to keep descriptive simplicity.

What are the information states for a machine agent, that is the collaborative process sub-model for a human agent. The property set of the Navigator agent has the collaborative process sub-model of the Navigator as *taskmodel*. This model allows switching the tasks to be executed by the Navigator agent, e.g. by setting (*taskmodel*, *Helmsman*).

$$P_{A_{Navigator}} = \left\{ (taskmodel, Navigator), (position, (8,1,1)), (geometry, G_{Navigator}) \right\}$$

#### 4.5.1.3 Output

By having processed the input, an Integrated Model was created. It consists of the Information Model, the Collaborative Process Model and the Spatial Model. The Collaborative Process Model already includes how work is organized in-between the human agents. But, the *Resource Management* is not covering the interaction between human and machine agents, yet. The Integrated Model  $IM = (IE, M, A)$  represents the output that is handed over to the next modelling sub-process.

## 4.5.2 Model Execution Planning & Verification

On the basis of the Integrated Model as output from the previous step, it is planned how the work of the human agents will be executed on the Spatial Model. This is done by creating SA Transactions. The sum of all SA Transactions joint with the temporal order of work execution in the Collaborative Process model constitutes the work execution plan. The plan is verified for non-existence of Information Gaps after planning.

### 4.5.2.1 Input

The Integrated Model  $IM = (IE, M, A)$  is an input to this step and is required to be defined accordingly: The Information Model  $IE$  needs to contain every information element, that is referenced over the properties of *information<sub>supply</sub>* and *information<sub>demand</sub>* in the Collaborative Process Model  $M$  and the Spatial Model  $A$ . Further, each of the human agents in  $A$  ( $Agents_M$ ) are required to have a *taskmodel*, that exists in  $M$ , and a *position* property assigned. The properties *position* need to be defined for machine agents ( $Agents_M$ ) as well as their *current<sub>state</sub>* and the *information<sub>states</sub>*. For execution planning it is explicitly not necessary to have the agent's geometry set up.

### 4.5.2.2 Process

This approach fosters two ways to plan execution of work in the work space: Manual Planning and Automated Heuristical Planning. The automated method requires to review the work plan and to carry out adjustments to the work plan, if needed.

In general, the objective of this process is to create SA Transactions ( $T_{SA} = \{t_{SA_1}, t_{SA_2}, \dots, t_{SA_n}\}$ , see chapter 4.2), that represent the fulfillment of the information supply and information demand, which is described with the properties of human agents' *taskmodell* elements ( $E$ ). The fulfillment of this humans' supply and demand is modelled through SA Transactions, which reference information supply and demand of machine agents ( $Agents_M$ ) and human agents ( $Agents_H$ ).

### Temporal Ordering of SA Transactions

The temporal order of execution of SA Transactions can be partwise inferred from the sequential ordering of elements ( $E$ ) in the Collaborative Process Model. There, synchronous execution of team tasks between multiple agents is made explicit through the subset of team work elements ( $E_{A_i Team} \subseteq E_{A_i}$ ), that are connected over synchronous relationships

$(R_{A_i \text{Synchronous}} \subseteq R_{A_i})$  and imply a temporal parallelized execution. This is different from task work elements ( $E_{A_i \text{Task}} \subseteq E_{A_i}$ ): Imagine a Collaborative Process Model with two agents, each having three task elements and no collaboration ( $R_{A_i \text{Synchronous}} = \emptyset$ ). There it's unclear how the task elements temporally correspond to each other and thus the execution order of the tasks is unspecified: The first agent may execute all tasks before the other, vice versa or task execution may be mixed arbitrarily temporal. For evaluating a design, it is necessary to know about the temporal order, since human agents may impede each other during work on/with the same machine agent. A temporal order property is introduced to encounter this problem.

The conceptual SA Transaction definition is therefore extended, as follows:

- $P_{t_{SA_i}} = \{p_{t_{SA_{i_1}}}, p_{t_{SA_{i_2}}}, \dots, p_{t_{SA_{i_n}}}\}$ , is a finite set of properties of an SA Transaction  $t_{SA_i}$ .
- $p_{t_{SA_{i_n}}}$  is an ordered pair, that defines a name and value (e.g.  $(interval, "1")$ ).
- $\forall t_{SA_i} \in T_{SA} : P_{t_{SA_i}} \in t_{SA_i}$ , every SA Transaction has a set of properties.
- $\forall t_{SA_i} \in T_{SA} \exists p_{t_{SA_{i_n}}} \in P_{t_{SA_i}} : p_{t_{SA_{i_n}}} = (interval, n \in \mathbb{N})$ , asserts that every SA Transaction in  $T_{SA}$  has a property with the name *interval*, that is a natural number indicating the position in a temporal ascending execution order.

SA Transactions having the same *interval* are ought to be executed in parallel. During planning the execution order position are assigned to SA Transactions. Both planning methods, automated and manual planning, are explained in the following sub-chapters.

#### **4.5.2.2.1 Manual Planning**

In manual planning an SA Transaction  $t_{SA_i}$  is created on the planner's choice. This choice is about which information supply is fulfilled with which information demand and vice versa: For every of the human agents' *taskmodell* elements ( $E$ ), the sets *IS* and *ID* corresponding to the properties for *information<sub>supply</sub>* and *information<sub>demand</sub>* are inspected.

First, team tasks are transferred into SA Transactions. This is done by resolving two connected team elements in  $E_{A_i \text{Team}}$  over the corresponding synchronous relation in  $R_{A_i \text{Synchronous}}$ . Let these team elements be  $e_{T_1}$  and  $e_{T_2}$  and  $t_{SA_1}$  and  $t_{SA_2}$  be SA Transactions, then  $\tau(t_{SA_1}) = \{(x, y) \in IS \times ID \mid x \in e_{T_1 \text{IS}}, y \in e_{T_2 \text{ID}}, x = y\}$  and  $\tau(t_{SA_2}) = \{(x, y) \in IS \times ID \mid x \in e_{T_2 \text{IS}}, y \in e_{T_1 \text{ID}}, x = y\}$  where  $e_{\varphi \text{IS}} := q$ , where  $(information_{supply}, q) \in P_{e_{\varphi}}$  and  $e_{\varphi \text{ID}} := q$ , where  $(information_{demand}, q) \in P_{e_{\varphi}}$ . Of course the SA Transaction function can result in

an empty set, if there is no match between information supply and demand. Thus, a vocal informing by one agent may be modelled with one SA Transaction, whereas in contrast a dialog, with request and response, being (abstractly) modelled with one synchronous relation would result in two SA Transactions.

Second, SA Transactions are created from task work elements ( $E_{AiTask}$ ) of every human agent. For a task's information demand set  $ID$  an information supply set needs to be found in the information states' ( $IStates$ ) of an machine agent in  $Agents_M$ . Analogously, an information demand set needs to be found in the information states of an machine agent for a task's information supply set  $IS$ . Let  $e_1$  be a task work element in  $E_{AiTask}$  and  $e_{state1}$  be an information state in  $IStates$  of an machine agent,  $t_{SA_1}$  and  $t_{SA_2}$  be SA Transactions, then  $\tau(t_{SA_1}) = \{(x, y) \in IS \times ID \mid x \in e_{1IS}, y \in e_{state1ID}, x = y\}$  and  $\tau(t_{SA_2}) = \{(x, y) \in IS \times ID \mid x \in e_{state1IS}, y \in e_{1ID}, x = y\}$ . Again  $\tau$  may yield an empty set.

Third, temporal *interval* properties are defined for every SA Transaction. If there exist two SA Transactions, that correspond to the same  $R_{AiSynchronous}$ , then both *interval* numbers need to be equal. While assigning interval numbers to the SA Transactions, the sequential order of team and task elements given with  $R_{AiSequential}$  needs to be kept, meaning that the *interval* number of SA Transactions from/to a sequence's source may not be higher than the *interval* number of SA Transactions from/to a sequence's target. Albeit interval numbers of sequentially-connected task elements may have identical interval numbers. The interval is defined:

- $t_{SAinterval} := \text{interval number of } t_{SA}$ .

How fitting information states can be found in manual planning depends: If the context of use provides descriptions on the Resource Management, then this thesis' approach allows incorporating these Resource Management descriptions. If the Resource Management still needs to be persisted during designing, then this approach allows testing different Resource Management configurations via adaption of SA Transactions (e.g. by altering an information demand to be fulfilled with an information state of a different agent). In any case it is sensible to conduct human factors experts and subject matter experts for validation of the work plan completed by construction of the SA Transactions.

#### 4.5.2.2.2 Automated Heuristical Planning

In automated heuristical planning algorithms are used to create SA Transactions. Team tasks can be transferred into SA Transactions as described with manual planning. Temporal ordering of SA Transactions over *interval* numbers is done analogous to manual planning. The difference between manual and automated planning is in the creation of SA Transactions for task work:

Heuristics are used to computationally determine matching information supply and demand of between human agents (task work elements) and machine agents (information states). They are applied for automated planning that facilitate any combinations of the properties of human and machine agents in *Agents*. Under the assumption, that a task's *IS* and *ID* shall be fulfilled with minimal  $IG^+$  and  $IG^-$ , it is possible to describe the general aim of a planning heuristic as mathematical optimization problem:

$$\begin{aligned} & \text{maximize } \sum_{t_{SA} \in T_{SA}} |\psi_{IS}(t_{SA}) \cap \psi_{ID}(t_{SA})|, & \text{minimize } \sum_{t_{SA} \in T_{SA}} |\psi_{IS}(t_{SA}) - \psi_{ID}(t_{SA})|, \\ & \text{minimize } \sum_{t_{SA} \in T_{SA}} |\psi_{ID}(t_{SA}) - \psi_{IS}(t_{SA})|, & \text{minimize } |T_{SA}| \end{aligned}$$

This means, an optimal solution to the problem is found, when the sum of the cardinality of all information supply and demand matching situations *MS*, that exist between human task element and machine agent's information state, is maximized, and the cardinality of the SA Transaction set,  $IG^+$  and  $IG^-$  is minimized.

A heuristic striving towards an optimal solution may specialize the general optimization problem for defined element properties. E.g. for function-oriented layouts of workstations, as described in chapter 2.2, work execution of agents may be planned centrally, meaning from a defined workplace. Therefore, the heuristic could e.g. facilitate the *position* property of a human agent as its workplace and then chose the closest workstation, which is fulfilling a task element's supply and demand to create SA Transactions. The closeness can be added to the optimization e.g. as minimization of the Euclidean distance between workplace and workstation positions.

#### 4.5.2.2.3 Manual Plan Adjustment

Likewise manual planning, in automated planning the automatically generated work plan should be validated. If the context of use contains designed interactions, which should have been automatically created by heuristics, then they can be compared to the created SA



Transactions. Elsewise, a planner may carry out an ocular inspection of the SA Transaction, to identify differences to an intended work execution plan. Therefore, it is again sensible to consult human factors experts and subject matter experts. If the verification of inspection results requires a change of the work plan, then SA Transactions can be adjusted. Then, the SA Transaction  $t_{SA_1}$  requiring adjustment is selected from  $T_{SA}$  and redefined, where either *IS* or *ID* is adjusted, and the opposite is not adjusted.

#### 4.5.2.2.4 Work Plan Verification

After automatic or manual planning, the Resource Management is created in form of collaborative processes and SA Transactions. Both planning methods incorporate human planners, who may have induced errors to the plan, such as missing SA Transactions. Hence, the work plan is verified in this step. There exists four aspects of verification, that are elaborated in the following.

#### Consistency to Collaborative Process Model

First of all, consistency of the Integrated Model to the human tasks' information supply and demand is verified. Here consistency means formally that there exists at least one SA Transaction for every *IS* and *ID* of the elements  $E$  in  $M$ , where *IS* and *ID* is not empty. These SA Transactions either map to other elements in  $E$  or to a machine agent's information state supply or demand set in  $E_{states}$ . The following assertions must be true, to have SA Transactions that are consistent to the Collaborative Process Model:

- $\forall e \in E_{AiTeam} \forall x \in e_{IS}, y \in e_{ID} \exists t_{SA_1}, t_{SA_2} \in T_{SA}: x \in \psi_{IS}(t_{SA_1}), y \in \psi_{ID}(t_{SA_2})$
- $\nexists e \in E_{AiTeam} \exists f \in E_{states}, t_{SA_i} \in T_{SA}: (\omega_{IS}(t_{SA_i}) = f, \omega_{ID}(t_{SA_i}) = e) \vee (\omega_{IS}(t_{SA_i}) = e, \omega_{ID}(t_{SA_i}) = f)$
- $\forall e \in E_{AiTask} \forall x \in e_{IS}, y \in e_{ID} \exists t_{SA_1}, t_{SA_2} \in T_{SA}: x \in \psi_{IS}(t_{SA_1}), y \in \psi_{ID}(t_{SA_2})$
- $\nexists e \in E_{AiTask} \exists f \in E, t_{SA_i} \in T_{SA}: (\omega_{IS}(t_{SA_i}) = f, \omega_{ID}(t_{SA_i}) = e) \vee (\omega_{IS}(t_{SA_i}) = e, \omega_{ID}(t_{SA_i}) = f)$
- $\omega_{IS}(t_{SA}) := Agent\ of\ t_{SA}'s\ IS, \omega_{ID}(t_{SA}) := Agent\ of\ t_{SA}'s\ ID$

#### Interval Verification

Besides consistency to the Collaborative Process Model, it is verified that the *interval* order of SA Transactions is analogue to the Collaborative Process Model. Meaning that SA Transactions from/to a sequence's source may not be higher than the *interval* number of SA Transactions

from/to a sequence's target. This is expressed in the following terms that are fostering non-existence of a violating  $t_{SA_1}$ .

- $\nexists t_{SA_1} \in T_{SA}, \exists t_{SA_2} \in T_{SA}, e_1, e_2, e_3, e_4 \in E, r_{A_{iS_1}}, r_{A_{iS_2}} \in R_{A_{iSequential}} : (r_{A_{iS_1}} = (e_1, e_2) \wedge r_{A_{iS_2}} = (e_3, e_4)) \wedge (((\omega_{IS}(t_{SA_1}) = e_{1IS}, \omega_{ID}(t_{SA_1}) = e_{3ID}) \vee (\omega_{IS}(t_{SA_1}) = e_{3IS}, \omega_{ID}(t_{SA_1}) = e_{1ID})) \wedge ((\omega_{IS}(t_{SA_2}) = e_{2IS}, \omega_{ID}(t_{SA_2}) = e_{4ID}) \vee (\omega_{IS}(t_{SA_2}) = e_{4IS}, \omega_{ID}(t_{SA_2}) = e_{2ID}))) \wedge (t_{SA_1interval} > t_{SA_2interval}))$
- $\nexists t_{SA_1} \in T_{SA}, \exists t_{SA_2} \in T_{SA}, e_1, e_2 \in E, es_1, es_2 \in E_{states}, \exists r_{A_{iS_1}} \in R_{A_{iSequential}} : (r_{A_{iS_1}} = (e_1, e_2) \wedge (((\omega_{IS}(t_{SA_1}) = e_{1IS}, \omega_{ID}(t_{SA_1}) = es_{1ID}) \vee (\omega_{IS}(t_{SA_1}) = es_{1IS}, \omega_{ID}(t_{SA_1}) = e_{1ID})) \wedge (((\omega_{IS}(t_{SA_2}) = e_{2IS}, \omega_{ID}(t_{SA_2}) = es_{2ID}) \vee (\omega_{IS}(t_{SA_2}) = es_{2IS}, \omega_{ID}(t_{SA_2}) = e_{2ID}))) \wedge (t_{SA_1interval} > t_{SA_2interval}))$

### Conflicts between Human Agents

Further, problems may occur during work of two or more human agents executing SA Transactions with the same machine agent at the same time (*interval*): SA Transactions may point to different information states of a machine agent. This causes a conflict, since both human agents may impede the other's agent work. During work plan verification it is ensured, whether those conflicts exist in the Integrated Model. Existence of such a conflict is not given, if:

- $\nexists t_{SA_1}, t_{SA_2} \in T_{SA}, \exists e_{a1} \in E_{A1}, e_{a2} \in E_{A2}, e_{state1}, e_{state2} \in Agent_{Minformationstates} : (t_{SA_1interval} = t_{SA_2interval}) \wedge (((\omega_{IS}(t_{SA_1}) = e_{a1IS}, \omega_{ID}(t_{SA_1}) = e_{state1ID}) \vee (\omega_{IS}(t_{SA_1}) = e_{state1IS}, \omega_{ID}(t_{SA_1}) = e_{a1ID})) \wedge ((\omega_{IS}(t_{SA_2}) = e_{a2IS}, \omega_{ID}(t_{SA_2}) = e_{state2ID}) \vee ((\omega_{IS}(t_{SA_2}) = e_{state2IS}, \omega_{ID}(t_{SA_2}) = e_{a2ID}))))$
- $Agent_{Minformationstates} := IStates\ of\ Agent_M$

### Satisfiability of Human Agents' Information Supply and Demand

The final step in work plan verification is to assure that the information supply and information demand, modelled as property of every human agent's *taskmodel* element, is satisfiable over all SA Transactions created during planning. Therefore, initially four sets are built from the Integrated Model:

- $HA_{IS}$  is the union of all human agents' information supply sets, that exist in *information<sub>supply</sub>* properties of  $E_{A_{iTeam}}$  elements.

- $HA_{ID}$  is the union of all human agents' information demand sets, that exist in  $information_{demand}$  properties of  $E_{AiTeam}$  elements.
- $HM_{IS}$  is the union of all human agents' information supply sets, that exist in  $information_{supply}$  properties of  $E_{AiTask}$  elements.
- $HM_{ID}$  is the union of all human agents' information demand sets, that exist in  $information_{demand}$  properties of  $E_{AiTask}$  elements.
- $MA_{ID}$  is the union of all information demands of all  $information_{states}$  of  $Agents_M$ ,
- $MA_{IS}$  is the union of all information supplies of all  $information_{states}$  of  $Agents_M$ .

Under the precondition that all other validation assertions have been verified successfully, the human agents' information supply and demand is satisfied, if  $(HA_{IS} = HA_{ID}) \wedge (HM_{IS} - MA_{ID} = \emptyset) \wedge (HM_{ID} - MA_{IS} = \emptyset)$ .

In case of failure in verification, the Integrated Model and SA Transaction set provide a joint structure that allows backtracking deficiencies over SA Transactions to the Integrated Model. Adjustments that cancel out the deficiencies can then be carried out on SA Transactions and/or the Integrated Model to create a valid Integrated Model-SA Transaction conjunction.

#### 4.5.2.3 Output

After Model Execution Planning & Verification the Integrated Model  $IM = (IE, M, A)$  is complemented with a set of SA Transactions  $T_{SA}$ . These SA Transactions constitute both interactions in-between human and human, and human and machine. They were created manually or automated with heuristics and validated afterwards. SA Transactions provide a distinguishable temporal order of collaborative task and team work that is annotated as a natural number in the *interval* property. Further, the  $IM$  and  $T_{SA}$  sets have been verified jointly for consistency, correctness of temporal order, conflicts between agents, and satisfiability of humans' information supply and demand. Both outputs ( $IM$  and  $T_{SA}$ ) are handed over to the next step of this method: Simulation.

## 4.6 Simulation - Process Execution in Work Spaces

The second step in assessing the spatio-temporal information supply and demand fitness is to simulate the execution of the Resource Management, which is defined through the Integrated Model and SA Transactions.

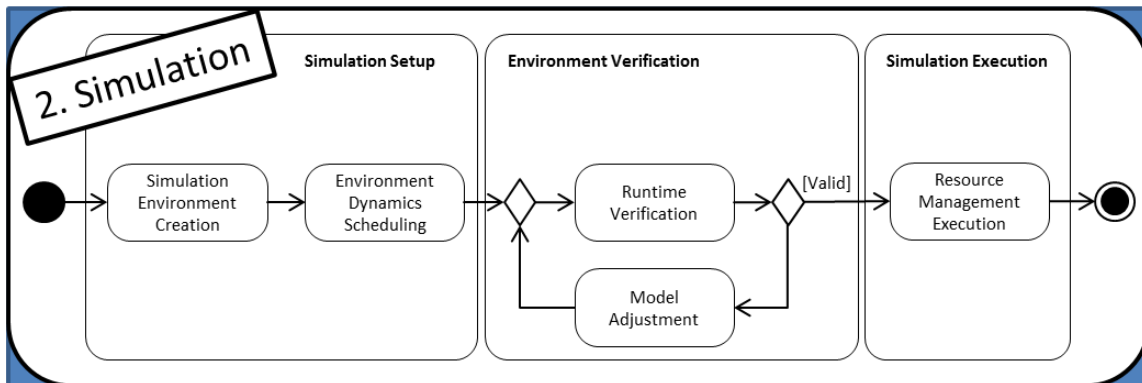

**Figure 35: Step 2 - Simulation - Process Execution in Work Spaces**

According to Shannon simulation “is the process of designing a model of a real system and conducting experiments with this model for the purpose either of understanding the behavior of the system or of evaluating various strategies [...] for the operation of the system.” (Shannon 1975). In this approach, the principal design of the model has been achieved with the modelling method described in step 1 (see chapter 4.5). In this simulation step, the modelling focusses on creation of an environment considering Integrated Model’s agents as a constituting part and overall dynamical aspects that may exist in the environment (chapter 4.6.1 Simulation Setup). The Resource Management is then used to evaluate the spatial environment: The environment is verified for non-violation of work environment limitations (chapter 4.6.2). The Resource Management is then executed on/in the verified environment (chapter 4.6.3). Outputs are provided for analysis, fostering understanding (of the Resource Management) in Shannon’s sense, as described within the next chapter (chapter 4.7 - Analysis).

In the following, the simulation approach, with its three sub-processes is defined in detail with underlying concepts, inputs to the processes and outputs of the processes.

#### 4.6.1 Simulation Setup

The setup of the simulation is the initial step of this simulation method. The sub-chapters describe the inputs to this step, the process of setting up the work environment for simulation with the Integrated Model and the outputs of this step, which are used in Environment Verification (chapter 4.6.2).

#### 4.6.1.1 Input

To set up a simulation in this approach, the Integrated Model and SA Transactions (=Resource Management) are used. Further, inputs are geometrical descriptions of the work environment, human and machine agents' "body" geometries, and descriptions of their sensomotoric geometries.

The work environment input should be provided as a description of an n-dimensional space that has a defined hull, described as a geometrical form. That hull could for example symbolize/consist of walls, doors and windows, and is relevant for this method's environment evaluation. The environment contains the agents and artifacts (as in DSA). Artifacts can be f.i. chairs, tables and lights. For them positions and geometries need to be provided, if they shall be subject to assessment.

Agents' positions have already been defined during modelling, hence their "body" geometries and sensomotoric geometries need to be provided as inputs to the simulation setup.

As described with the modelling inputs (chapter 4.5.1.1), the context of use provides technical drawings and layouts of machine agents and artifacts, such as displays and control panels. These drawings can provide arbitrarily complex body geometries of artifacts, from simple planes to concave or convex geometries.

#### 4.6.1.2 Process

Setting up the simulation is done by facilitating the input (chapter 4.6.2.1) to create the simulation environment (chapter 4.6.1.2.1) and scheduling dynamic changes in that environment (chapter 4.6.1.2.2).

##### 4.6.1.2.1 Simulation Environment Creation

During the creation of the simulation environment, (early) User Interface design ideas from HCD-Process Activity 3 are used to enrich the Spatial Model and create a scene graph. These ideas consider the overall geometrical design of the working environment, body geometries, and sensomotoric geometries, which are regarded in the following and depicted for the accompanying use case in Figure 36. The scene graph, is a graph with a tree structure that contains the environment's hull as a node, references the agents of the *IM* as nodes, contains the artifacts' bodies as nodes and the sensomotoric geometries as their child-nodes.



**Figure 36: Visualization of the Use Case's Simulation Environment with its hull (1), human and machine agent body geometries (2), sensomotoric geometries (3) and artifacts (4)**

### Environment's Hull

The hull forms the boundary of the simulation environment. It constraints the freedom of movement of human agents and thus is relevant for verification of the working environment (see chapter 2.2) in the next process-step (chapter 4.6.1.2.2), e.g. to evaluate pathways' width. The hull can be defined in arbitrary ways with physical objects, such as walls, doors, windows, floors, ceilings, ceiling-substructures, and landings. On Figure 36, the walls, windows and a floor of the environment are visible. Similar to an agent's geometry, the environment is specified as an undirected graph ( $G = (V, E)$ ), that consists of a set of vertices ( $V$ ) and edges ( $E$ ). Again, vertices are in  $S^n$ .

### Body Geometries

Geometrical bodies of agents are added to their *IM's geometry* parameter and bodies of artifacts are added with their desired position to the scene graph. These are f.i. consoles, tables, or chairs (Figure 36 - 4). Machine agent's body geometries are extracted from the context of use, technical drawings, or may be created within this step.

For human agents anthropometric bodies are specified, since body sizes influence positioning of sensomotoric geometries. Human anthropometrics vary and thus it can be sensible to fit the human agent body between the lower, upper or average body percentile (Tilley & Associates 2002) of the future users.

### Sensomotoric Geometries

The geometries for every considered modality are added to the scene graph as well. Human agent's sensomotoric geometries are positioned at their corresponding sense position of the body geometry. E.g. the sensomotoric geometry for vision is aligned to the body's eyes (Figure 36 – 3). As described with the concept (chapter 4.3 and 2.2), the form can be taken from

relevant standards and literature. Similar, machine agents' sensomotoric geometries can be derived from technical specification, or, if not existing, be calculated or elicited during an experiment with target users. E.g. for calculation of good vision of information elements, expressed by a vision geometry, the Rayleigh Criterion (Rayleigh 1879) for diffraction-limited vision in conjunction with the inverse-square law may deliver an acceptable approximation. Further, sensomotoric geometries are linked to the properties of all information demand sets (*IDS*) and information supply sets (*ISS*).

#### 4.6.1.2.2 Environment Dynamics Scheduling

During runtime of the simulation the Resource Management will be executed with the created simulation environment. But, there may be external triggers that affect the working environment and are not covered by the Resource Management, yet. Exemplary scenarios are: a sensory system switching information states of a machine agent, alteration of an artifacts position, illumination reduction (change of sensomotoric geometries). In this method, triggers and their effects are defined in a schedule. Thus, the schedule holds pre-planned dynamics that are executed during runtime of the simulation.

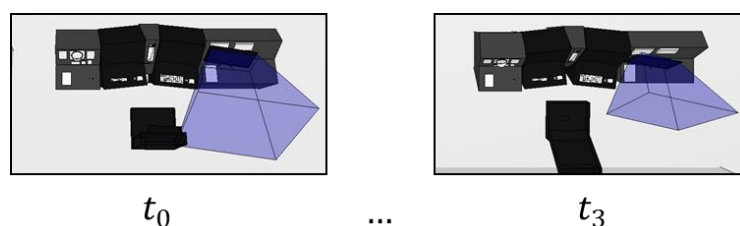

**Figure 37: Visualization of two scene graphs scheduled at  $t_0$  and  $t_3$ : Changes were applied to the chair's body geometry and display's sensomotoric geometry**

The simplistic application of the schedule is shown with Figure 37: At a pre-defined interval ( $t_3$ ), an alternative scene graph is set, that contains alterations to be applied during simulation. Here, the radar operator chair's body geometry has been changed - the chair is set to 'relax-mode' - and the sensomotoric geometry of the ECDIS display was shrunk. The schedule  $EDS = \{se_1, se_2, \dots, se_n\}$  is formalized as a finite set of schedule entries ( $se_n$ ). Every  $se_n$  is an ordered pair, that defines a *interval* number and scene graph as value (e.g.  $(0, "sg1")$ ).

Of course it is possible to integrate more sophisticated triggers at this step. E.g. an agent entering a defined area could be used as a trigger to fire an information state change of a machine agent. Therefore, dedicated observer techniques are required *in operando*. With this method's schedule (*EDS*) the area-entrance trigger would be implemented by adding a

schedule entry with an adjusted scene graph at the *interval* of an SA Transaction, that forces the agent to enter the defined area.

#### **4.6.1.3 Output**

Defined output of this process is the schedule (*EDS*) that is referencing the set up scene graphs for all intervals existing amongst the SA Transactions.

### **4.6.2 Environment Verification**

Based on the scene graphs, the working environment is verified for compliance to requirements on physical spaces, which are defined in standards, guidelines and regulations. During verification occupancy grids are created, that are facilitated for human agent's path finding in Resource Management Execution (chapter 4.6.3).

For ship bridge design the space requirements are described in chapter 2.2. They consider physical spaces between machine agents and the environment's hull as pathways for operators. In this sub-chapter a method for semi-automated verification for compliance to these requirements is described. Further, a successful verification anticipates human agents' information access issues that may occur during Resource Management Execution (chapter 4.6.3).

#### **4.6.2.1 Input**

The method facilitates all scene graphs set up, as described in the previous chapter 4.6.1. Further, requirements from standards, regulations and guidelines, defined in the context of use, are taken as inputs to these sub-processes.

#### **4.6.2.2 Process**

The environment verification has two sub-processes. These are firstly execution of the Runtime Verification (chapter 4.6.2.2.1) and secondly identifying whether a Model Adjustment (chapter 4.6.2.2.2) is required to achieve compliance to the context of use.

##### **4.6.2.2.1 Runtime Verification**

During work operations, human agents require spaces between machine agents, artifacts and the environment's hull. These spaces are often defined with minimum horizontal and vertical distances, aiming for enabling ergonomic operation. For ship bridge design these requirements



---

are described in chapter 2.2. They consider physical spaces between machine agents and the environment's hull as pathways for operators. In this sub-chapter a method for semi-automated verification for compliance to these requirements is described.

The general idea of the method is to use multiple virtual test specimens to create occupancy grids of the work environment. Occupancy grids are well-known in the area of robot interaction (Moravec & Elfes 1985). There an occupancy grid "is a multidimensional random field that maintains stochastic estimates of the occupancy state of the cells in a spatial lattice. To construct a sensor-derived map of the robot's world, the cell state estimates are obtained by interpreting the incoming range readings using probabilistic sensor models." (Elfes 1989). In this method, the test specimens are set to every cell of a fine-grain spatial lattice over each scene graph. The occupancy state of a cell (in the lattice) is set *occupied*, if the test specimen collides with machine agents, artifacts or the environment's hull. Created occupancy grids are used to extract occupied areas, which are compounds of occupied cells. Subsequently, the actual amount of occupied areas (for a scene graph) is compared against a target amount. If both amounts differ, the design violates requirements (actual amount < target amount) or the designer has to identify whether requirements are violated (actual amount > target amount).

### **Test Specimen**

For successful application of this method, a specimen needs to be defined. That test specimen is used to generate a requirement-fulfilling occupancy grid. It has the geometrical form of a cylinder, a diameter that is equal to the minimum horizontal space, and a height that is equal to the minimum vertical space. For ship bridge design, there exist multiple space requirements. E.g. a test specimen with a diameter of 600mm and height of 2000mm could be derived from chapter 2.2. From occupancy grid generated with the test specimen a designer can directly see at a glimpse and compare with the scene graph whether pathways have the correct spacing and deck height.

### **Inter- and Intra-Scene Graph Verification**

If there are multiple requirements existing on horizontal and vertical spacing, as in ship bridge design, the verification is getting more complex: Further test specimens are required, which allow verifying the compliance to these requirements. To encounter this complexity, in this method lattice masks are created which define what kind of test specimen is used for a scene graph. For each mask the according test specimen is be applied. The process of using masks for varying test specimen is called Inter-Scene Graph Verification. Its result is an occupancy grid created with the different test specimen.

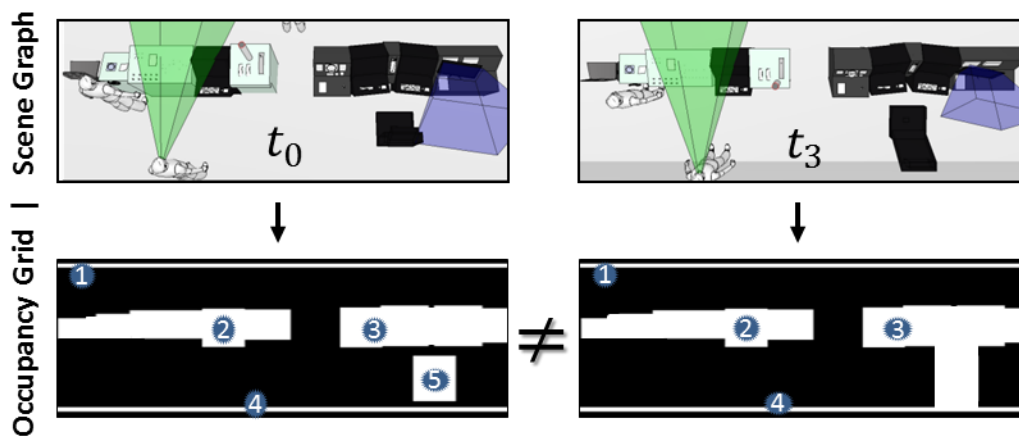

**Figure 38: Intra-Scene comparison of occupied areas: In  $t_3$  a required pathway to the ECDIS is obstructed – the amount of occupied areas is not equal ( $5 \neq 4$ )**

Once the (compound) occupancy grid was created and compared for compliance by the designer. This and the specimen-masks can be used for an automated Intra-Scene Graph Verification of other scene graphs, defined in the schedule. For fast testing, again the actual and target amount of occupied areas can be used to identify incompliant designs, which may emerge during execution of the Resource Management. An example of Intra-Scene Graph Verification is shown on Figure 38 - in  $t_3$  the radar operator's chair violates the requirement for spacing between the right console and a rear wall.

#### 4.6.2.2.2 Model Adjustment

After runtime verification, the work environment is either verified to fulfill defined requirements, or it is not. In the latter case, the model needs to be adjusted. Therefore, not verified parts are tracked back visually to the scene graph. Within the scene graph nodes can be adjusted to achieve compliance. For example, positions and geometrical bodies of agents, artifacts and the hull can be altered. It is to be noted, that changes in one scene graph may need to be carried forward to other scene graphs. After adjustment of the scene graph the process of runtime verification is executed again, till model adjustment is not required anymore.

#### 4.6.2.3 Output

The output of these two sub-processes are *verified scene graphs*, which are compliant to the work environment's spacing requirements, and *occupancy grids*, which are used for pathfinding during Resource Management Execution in the next chapter.

---

### 4.6.3 Simulation Execution

Finally, the Resource Management is executed on the verified work environments within the set up schedule. Within this chapter, the general algorithmic procedure of resource execution is described. The execution is used to elicit human agents' cost for execution of SA Transactions. During analysis, in chapter 4.7, the results of execution are e.g. used to create Life and Motion Configurations for each SA Transaction, and to detect interferences during Resource Management Execution.

#### 4.6.3.1 Input

For execution the Integrated Model with SA Transactions and the verified scene graphs are required as inputs. It is relevant that both verification methods, in modelling (chapter 4.5.2) and simulation (chapter 4.6.2), were successful to execute the Resource Management. Otherwise, an analysis (as described in the following chapter) could lead to false interpretations, since interference detection is focusing on insufficiencies in transactability of sensomotoric geometries. Of course, insufficiencies through an unsuccessfully verified integrated model (logically) or scene graph (physically) would contribute to insufficiencies in transactability as well.

#### 4.6.3.2 Process

Both inputs are taken into a process described as general execution of the Resource Management.

##### 4.6.3.2.1 General Resource Management Execution

The execution of the Resource Management is performed algorithmically. The general execution algorithm is depicted in Figure 39. The algorithm foresees that the set of SA Transactions is sorted by ascending interval numbers, as described in chapter 4.5.2.2. Environment dynamics are scheduled, if a scene graph is defined for a given SA Transaction' interval. The algorithm separates human and machine agents into *active* and *passive* agents. The separation portrays that for each SA Transaction there is precisely one agent, which is the acting/starting part in transaction execution and gets efforts accounted for his actions. This does not mean that passive agents have no efforts, but that the trigger for the passive agent's efforts is clearly defined to be the active agent's actions. An example is a (passive) human agent who is auditive receiving information supply and thus having efforts on reception of the

incoming information. For transacting information elements, the active agent is set to use the modality of the passive agent, which is providing the active agent with the supply or demand for an information element. If transactability for that modality is not given, the active agent plans and traverses its way into the closest sensomotoric geometry for that modality of the passive agent's information supply or demand. Therefore, collisions between the sensomotoric geometry and the active agent's body geometry are calculated.

```
1. function executeResourceManagement()
2.   executionDataSet.init()
3.   transactions = [∀t ∈ TSA]
4.   sortTemporal(transactions)
5.   for each t in transactions
6.     envScheduler.schedule(t)
7.     activeAgent = t.getActiveAgent()
8.     passiveAgent = t.getPassiveAgent()
9.     modality = passiveAgent.getModality(t)
10.    if !transactability(t,modality) then
11.      path = activeAgent.findPath(grid, passiveAgent.getSensomotoricGeometry(modality))
12.      traversalEffort = activeAgent.traverse(path)
13.      posturalEffort = activeAgent.orientModalityTo(passiveAgent, modality)
14.    end
15.    matchingSituation = match(t, activeAgent, passiveAgent)
16.    transactionEffort = activeAgent.transact(t, passiveAgent)
17.    effortSet = [t, traversalEffort, posturalEffort, transactionEffort, matchingSituation]
18.    lmc = formalize(t);
19.    executionDataSet.add([lmc,effortSet])
20.  end
21.  return executionDataSet
22. end
```

**Figure 39: Algorithm for Resource Management Execution in Pseudocode**

Having traversed, the active agent applies postural changes by reorienting its modality-corresponding sensomotoric geometry to the passive agent. This is achieving a collision of the sensomotoric geometry with the passive agent's body, and establishes transactability over sensomotoric geometries. Next, the matching situation is calculated; defining which information elements are elements of  $IG^+$ ,  $IG^-$  and MS. The geometries and body geometry of the active agent are used to detect other agents in the environment that are supplying or demanding information elements. E.g. other displays could provide information elements via the vision modality of the active agent. The transaction and its effort calculation for information elements in MS are executed afterwards. Transaction calls triggers on passive agent's effort calculation that is not further elaborated here. Under transaction efforts costs for active agent's work at the passive agent are accounted, f.i. costs for switching from one Information State to another. Efforts for traversal, postural change and transaction are added to an execution data set, which is used for LMC formalization, as described in the analysis chapter 4.7.

### 4.6.3.3 Output

The output of the process is an execution data set with accounted costs for human agent efforts and a reference on the corresponding causing SA Transaction. These outputs are forwarded to the analysis phase.

## 4.7 Analysis - Measure Provisioning & Assessment

The third and last step in assessing the spatio-temporal information supply and demand fitness is to (computationally) analyze the data produced during the simulation run and for the user to assess the analysis. Therefore, this chapter is split into Computational Analytics (chapter 4.7.1) and Assessment (chapter 4.7.2). The Computational Analysis can be executed fully automatic during execution of an SA Transaction while simulating. The Assessment provides steps that may ease interpretation by the analyst.

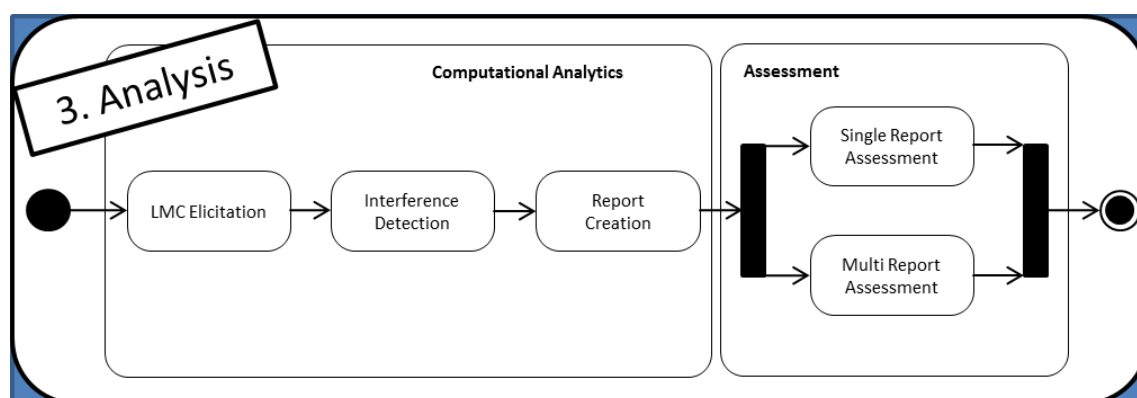

**Figure 40: Step 3 - Analysis - Measure Provisioning & Assessment**

Since DSA emerges from interactions (SA Transactions) between the agents and artifacts, the analysis focuses on measurable interaction. For individual SA Pritchett and Hansman (Pritchett & Hansman 2000) propose to measure operator's knowledge, verbalization or performance. In DSA, operator's memory is neglected, allowing only measurement relating to information provided by verbalization and performance, whose source are both modelled as SA Transactions in the IM as task and team elements of the CPM. On this basis the relations between information supply and demand can be described (qualitative) with the calculus and costs gathered during simulation run are measured (quantitative).

Following, the procedure of analysis, whose overview is depicted on Figure 40, is described.

### **4.7.1 Computational Analytics**

The computational analytics aims to provide comprehensive statistical data about a simulation run to the analyst. These data are presented in a report, which is used during assessment by the analyst (next sub-chapter) and shall enable understanding in Shannon's sense.

#### **4.7.1.1 Input**

Inputs to the Computational Analytics process are all elements of the *executionDataSet*, which was created during the general Resource Management Execution. Within each *effortSet* an SA Transaction is given. SA Transactions are used to resolve agents and artifacts from the IM, which is the second input to this process.

#### **4.7.1.2 Process**

During elicitation of LMCs, LMCs are formalized (chapter 4.7.1.2.1) on the basis of the *executionDataSet* and the IM (chapter 4.5 and 4.6). LMCs are then used for interference detection (chapter 4.7.1.2.2). Both, LMCs and detected interferences are used to create a statistical report about the simulation execution.

##### **4.7.1.2.1 Elicitation of Life and Motion Configurations**

During the algorithmic execution of the Resource Management, Life and Motion Configurations are elicited for every information element that is supplied or demanded by the active agent and is referenced by the given SA Transaction. The temporal interval of an SA Transaction is divided into multiple time slots during formalization into a Life and Motion Configuration. Every spatio-temporal state corresponds to a time slot and allows interpreting the given transactability or which actions are required to achieve transactability. In the following, general rules for formalization into LMC are described:

- If transactability is not given postural and/or traversal efforts would need to be applied to achieve transactability. States of supplied information elements with  $\exists IS$  and states of demanded information elements with  $\exists ID$ , and  $\exists IS \wedge \exists ID$  are the 6 trivially impossible states, since an information element cannot simultaneously exist and not exist.
- If transactability between supply and demand is given, transaction effort is accounted and the spatio-temporal fitness state is acquired:  $e$  for equality of the information elements, and  $d$  if they are disjoint.

- If there are further unintended SA Transactions, between the active agent and other agents, than the passive one, then this circumstance is accounted into MS and transaction effort calculation. E.g. there may be two displays in front of an operator, which allow transactability to the active agent via the sensomotoric vision geometry. Unintended SA Transaction's IE elements are formalized as separate LMC. It's to be obeyed that no double-formalization should be carried out.

There exist overall 14 possible states for expressing the transactability in states. 10 of these describe the non-transactability in 5 states expressing the supply and 5 states expressing the demand of an active agent's information element. All states are depicted in the table on Figure 41.

<i>Spatio-Temporal State</i>	<i>Human IE Supply</i>	<i>Human IE Demand</i>
$e$	$MS$	$MS$
$d$	$IG^+$	$IG^-$
$(IS)$	Position change required	State change required
$(ID)$	State change required	Position change required
$(IS) \wedge (ID)$	State & position change required	State & position change required
$\exists IS \wedge ID$	-	$IG^-$
$\exists IS \wedge (ID)$	-	Position change required
$IS \wedge \exists ID$	$IG^+$	-
$(IS) \wedge \exists ID$	Position change required	-
$\exists IS \wedge \exists ID$	-	-

**Figure 41: Table of spatio-temporal states with interpretation in set theory and required actions for Human-Machine Interaction. There exist 14 possible and 6 impossible states.**

In the use case, the LMC for the information element  $next_{course}$  in the Navigator's  $read_{course}$  would be  $LMC(ID_{next_{course}}) = \{(ID_{next_{course}}), e_{next_{course}}\}$ . The LMCs allow interpreting that the Navigator had to apply traversal and/or postural efforts to fulfill his  $next_{course}$  information demand. Cost figures calculated during general Resource Management Execution can be conducted to determine between traversal and postural efforts.

#### 4.7.1.2.2 Interference Detection

The elicited LMCs are used to detect interferences in RM execution. These are directly readable from LMCs, since previously executed verification methods did prevent logical problems (Work Plan Verification - chapter 4.5.2.2.4) and physical problems (Environment Verification - chapter 4.6.2), thus solely problems of sensomotoric geometries are left. The

inferences for transactability do exist in the RM, if there is an LMC about an information element,

- 1) which is supplied or demanded by a human agent,
- 2) which was specified in a SA Transaction, and
- 3) does never have  $e$  as final spatio-temporal state.

If such information element exists, interference is detected. Detected interference's LMC can be used to determine its originating SA Transaction, which enables to examine the work environment at the SA Transaction's *interval*. On resolution of the interference, the simulation execution may be executed again to gain an interference-free result. Up next: Creating a report for the assessment of the simulation run.

#### 4.7.1.2.3 Report Creation

Aim of report creation is to provide a statistical overview of the human agents' cost and interferences to the analyst. Therefore, it is suggested to create two kinds of reports: one report shall give an overview of the cost and interferences on a Collaborative Process Model's level (high level), and another report shall present the cost and interferences on the SA Transaction level (low level). Reason is that this hierarchical structure allows an analyst to compare both different RM configurations with each other on a set of indicators, and to investigate simulated fine-grain execution costs and interferences to backtrack their causes. To give a fast overview, statistical charts can be used to visually express relative order of magnitude between different SA Transactions' cost and aggregated process cost.

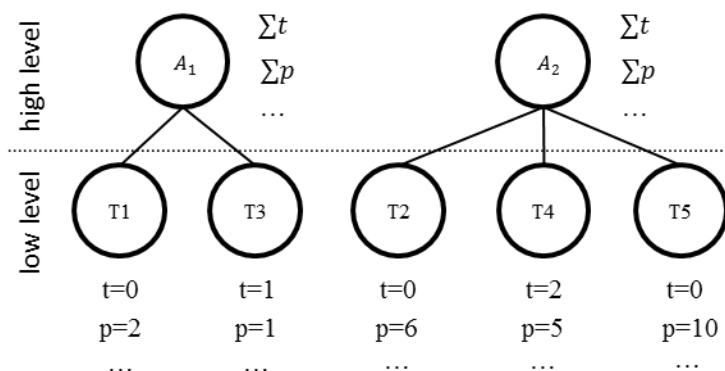

**Figure 42: Separation of reporting into high and low level cost aggregation for two agents**

As depicted on Figure 42, the high level aggregates all SA Transactions (T1-5) of each human agent, such that distribution of cost between agents is separable. Cost such as traversing cost ( $t$ ) and postural change costs ( $p$ ) are aggregated for each agent, by summation of absolute



values. On the high level, indicators about the low level can be displayed. Examples are the amount of SA Transactions, the amount of information elements transacted or a relative share on task and team work, and amounts of interferences. On the low level, direct access to raw simulation result data is given. For each SA Transaction efforts are displayable on a normalized bar chart. Interferences are annotated to their corresponding SA Transaction. On the low level insight into the LMC may enable the analyst to also execute a thought experiment about the simulation run, instead of inspecting the run e.g. in a simulation's visualization.

#### **4.7.1.3 Output**

Report sheets for the high level aggregation and low level presentation of the simulation run results are provided to the method's user.

#### **4.7.2 Assessment**

Finally, the last process step of the method needs to be executed by the user: Assessment. In Assessment, interferences need to be handled to give advice for optimization. This is a highly subjective task, which requires the analyst to judge on the simulated RM, based on statistical data within the scope of the analysis. There are two major kinds of assessments considered here - single assessment of one simulation run (chapter 4.7.2.2.1) and comparative assessment between multiple simulation runs (chapter 4.7.2.2.2), which are described in this step's process.

In both cases, the scope of a scenario, in which the RM is executed, is relevant for judging the goodness of the simulated system. In a safety relevant scenario, which is modelled with a RM, high execution cost may be judged negatively, since safety retentive actions require fast reaction and thus less execution cost. However, cost for transaction may not only have a negative impact, but can also have a positive impact in certain situations. E.g. in scenarios where human agents tend to get fatigued, compulsory movements may prevent from falling asleep. There may be plenty of room for judgments and different interpretations. To gain meaningful assessment results, the scope of each Collaborative Process can be persisted in the context of use. Thus, method users have a clear definition of considerable factors in assessment.

#### **4.7.2.1 Input**

Inputs to the assessment are the reports created during the Computational Analytics step. The scope of the assessment has been set and is gatherable form the context of use.

#### **4.7.2.2 Process**

The assessment process separates into single Report Assessment (chapter 4.7.2.2.1) and Multi Report Assessment (chapter 4.7.2.2.2).

##### **4.7.2.2.1 Single Report Assessment**

The aim of the Single Report Assessment is to find deficiencies in a RM. These deficiencies are then used to identify potentials to optimize the Spatial Model (SM) and/or the Collaborative Process Model (CPM). Under involvement of the process' scope the goodness of cost is judged. Depending on the scope, the definition of "optimal" varies. For safety relevant cases, which may require lowest costs, there exist a couple of indications that provide conspicuous candidates for optimization potential. These are:

- SA Transactions referencing multiple other agents for one task
- SA Transactions transacting a low amount (1-3) of task-required information elements
- Repetitive patterns of SA Transactions to multiple agents with high cost for traversal
- Repetitive patterns of SA Transactions to multiple agents with high cost for postural changes

Further deviations from average cost can be perceived visually from the report by the analyst. High deviations from average may indicate for optimization potential.

##### **4.7.2.2.2 Multi Report Assessment**

An alternative to Single Report Assessment is to compare multiple reports of different RM in the assessment. Therefore, either the underlying CPM or the underlying SM of considered executed RMs needs to be equal. Meaning, either the spatial layout or the process builds a fixed baseline in a comparative assessment. Figure 43 symbolically depicts the Multi Report Assessment. There, two different Spatial Models have been used with an equal set of Collaborative Process Models. Thus, the aggregated results of the high level report are comparable. Therefore again, the scope of the assessment has to be considered, to determine whether one alternative excels the other. CPM-wise aggregated cost of individual human

agents can be compared. Of course, low level reports can be considered, to identify more detailed SA Transaction-based differences.

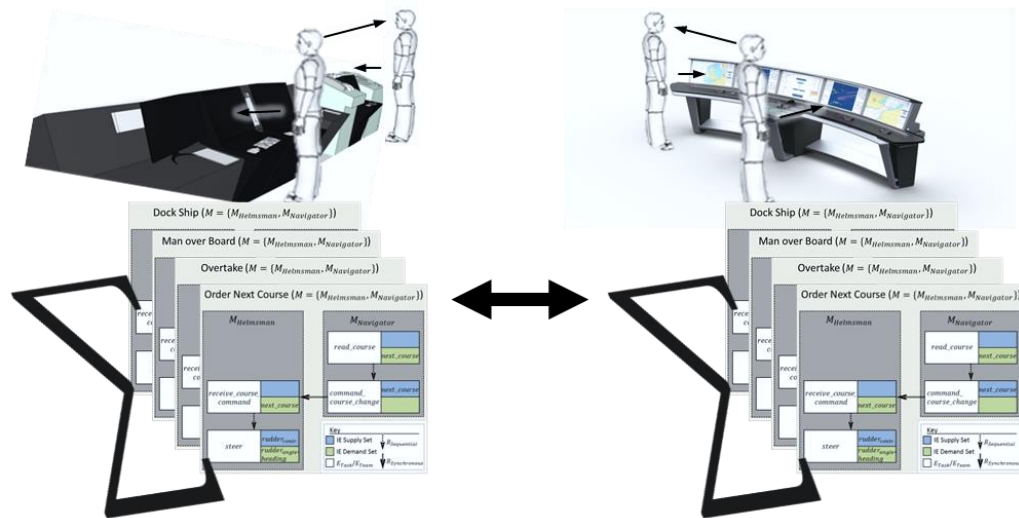

**Figure 43: Multiple Collaborative Process Models are used for comparative assessment of two Spatial Models**

#### 4.7.2.3 Output

As finalization, the results of both assessment processes are documented. Therefore, identified optimization potentials can help to drive a reiteration of the method with improved models. Results of the Multi Report Assessment can be especially helpful to keep track of weighted alternative RM.

## 4.8 Conclusion

With the aim to fulfill the objectives, requirements have been setup in chapter 3, which should be fulfilled with the concepts and method described in this chapter. In the following for each requirement group (RG1-3) fulfillment is described.

- RG1 focusses on the representation of information supply and demand of bridge and crew. For representation, there were deficiencies in the related work, which would be encountered by fulfilling R1-3. The set theoretical concept that allows loose coupling of information supply and demand is introduced (R1). The concept integrates SA Transactions of DSA theory, which match information elements of sets of information supply and information demand, whereas the sets are in possession of human or machine agents. After the Integrated Model's definition, the method provides

descriptions on how information elements can be coupled (chapter 4.5.2.2 on manual and automated planning of model execution). Agents, as well as information supply and demand sets, their CPMs, and the SM are part of an Integrated Model (IM) for spatio-temporality or crew work organization and bridge information distribution (R2). The IM and the set theoretical concept are described with mathematical formulae, providing precise semantics. On the basis of this description, the approach enables for symbolic verification of the IM (R3), which is supported within the method (chapter 4.5.2.2.4 on Work Plan Verification) and considering also temporal aspects.

- RG2 comprises requirements on the execution of crew work on the ship bridge. On the conceptual level, sensomotoric geometries are introduced defining transactability in a (work) space. The simulation step of the method describes particulars on setting up a work environment model (R4) as an extension to an IM, considering the sensomotoric geometries of agents for different modalities. Besides the temporal progress of human work, which is expressed in a CPM, the work environment may be dynamic during runtime (R6). The method allows to integrate runtime dynamics of the information distribution and of the overall work environment through scheduling of alternative scene graphs. The model needs to be verified for absence of ergonomic insufficiencies, occurring also through the environment dynamics (R7). Inter- and intra-scene graph verification approaches with test specimen are described to fulfill the requirement. To analyze the execution of an IM, the crew work execution is required to be deterministic (R5). Within the method, a generalized algorithm for Resource Management Execution is described (chapter 4.6.3 on simulation execution). Interfaces to cost functions are defined for traversal, postural change and transaction, which need to be minted deterministically in an implementation. While executing, the method foresees to integrate the simulation step with the analysis step, to capture the results of the simulation execution in an execution data set (R8).
- RG3 requirements aim towards provisioning of measurements to the method's user. Qualitative assertions about the supply and demand relations (R9) can be expressed with the Generalized Spatio-Temporal Reasoning Model for Information Supply and Demand (chapter 4.4) over LMCs. On the basis of the calculus, runtime dynamic interferences (R11) can be detected. Further, these allow to reason about the transactability of human and machine agents. Further quantitative assertions about supply and demand relations (R10) are expressed in reports, provided through the method's processes on Computational Analytics (chapter 4.7.1). The method's user

receives qualitative and quantitative assertions about the RM execution as a high-level and low-level report as described in chapter 4.7.2 on assessment (fulfilling R12).

All requirements are fulfilled. This has been shown with the application with the accompanying simple use case for changing the course in open waters (chapter 4.1). Within the evaluation (chapter 6), the implemented prototype ShiATSu (chapter 5) is applied to test the three hypothesis, which provide a more exhaustive application of the 3-step method and its concepts, with focus on the analysis phases' outputs.



## 5 Implementation of the ShiATSu Prototype

Within previous chapters of this thesis, the related work (chapter 2) was presented and used to derive requirements for a solution (chapter 3). On this basis a solution was presented, that fulfills the requirements (chapter 4). The solution consists of three State of the Art-extending concepts that are integrated into an accompanying method. To provide a holistic solution, the preceding descriptions of model's calculations and algorithms were implemented into a software prototype - the Distributed Situation Awareness Tool Suite - ShiATSu. The prototype is ought to support the applicability and execution of the presented method. The description of implementation, in this chapter, is therefore reflecting the method's three-step canon. Further, the implementation is used to verify feasibility of the conceptual solution and is employed in applications for succeeding evaluations in chapter 6. In this chapter ShiATSu's software architecture is shown (chapter 5.1) and details on implementation are given (chapter 5.2).

### 5.1 Architecture Design

ShiATSu is a Rich Client Platform (RCP) for modelling, simulation and analysis of Distributed Situation Awareness with this thesis' method. ShiATSu assembles four tree and diagram editors, a 3D model visualizer for modelling and simulation setup as well as several (verification-) tools that accompany the method for Assessment of Spatio-Temporal Information Supply and Demand Fitness. The prototype includes implementations of all algorithms for planning, execution and verification of a Resource Management, as presented within previous chapters. The Resource Management Execution provides LMCs and statistics about execution cost that are helpful during analysis. The diagram in Figure 44 gives an overview of the primary components of ShiATSu and their interrelations. The *LayoutEditor* is a central component, which uses and interfaces with all of the other seven ShiATSu-components.

The implementation reuses two components, which were developed for the eMIR<sup>3</sup> and HAGGIS platforms of OFFIS - Institute for Information Technology and the University of Oldenburg. These components are the Environment Modeller (*EMod*) and the Maritime Operation Planning Tool (*Mophisto*). The architectures of both components were reconstructed over reverse engineering. Besides these two, all other components were

---

<sup>3</sup> <http://www.emaritime.de/>, visited 20.01.2016

developed over the course of the thesis. Admittedly, the components StatechartEditor, Mophisto and EMod may be replaceable by classical state chart editors, collaborative process modellers such as BPMN editors and editors for 3D scene graphs, respectively. Whereas additions to these components, described in this chapter, would need to be implemented into replacing modellers/editors as well.

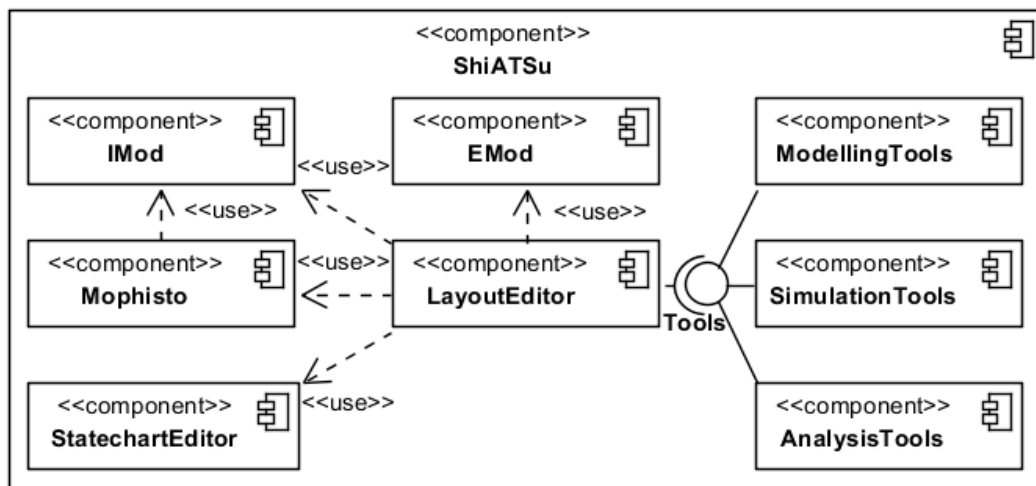

Figure 44: Component Diagram of ShiATSu

### 5.1.1 LayoutEditor

The LayoutEditor is a visual diagram editor that provides an editable schematic 2D top view perspective of a working environment, and its Resource Management, to the user. The *LayoutEditor* enables to import 3D environment models from EMod, to enrich the models of machine agents with IEs from IMod or with IE-enriched Statecharts (from *StatechartEditor* component), and to assign submodels of Collaborative Process Models from Mophisto to human agents. The *Tools* interface provides access to the LayoutEditor's and associated models, and thus works as an API for modeling, simulation and analysis tools, as depicted in Figure 44.

Figure 45 shows a class diagram of the LayoutEditor. The class *LayoutEditorSpace* reflects the diagram editor's background, and a palette and property view for creating, editing and deleting compound children and referenced objects. The *LayoutEditorSpace* is an *ElementWithName* and an *IToolsProvider*. *ElementWithName* is inherited by multiple Classes to enable referencing in-between all components. The *IToolsProvider* forces the LayoutEditor to implement an extension point, which allows to plug-in ShiATSu's ModellingTools, SimulationTools and AnalysisTools. *LayoutEditorSpace* references an *Environment* that is defined with EMod and a Collaborative Process Model that is defined with Mophisto. On the 98



diagram background of the *LayoutEditor* children of the *EditorSpacePart* subclass *WorkSpace* are drawn. *EditorSpacePart* is an abstract class, which allows for extension of the software towards analyses of the exterior of a work space. Children of a *WorkSpace* are *WorkSpaceParts* such as *HumanAgent*, *MachineAgent* and *Artifact*.

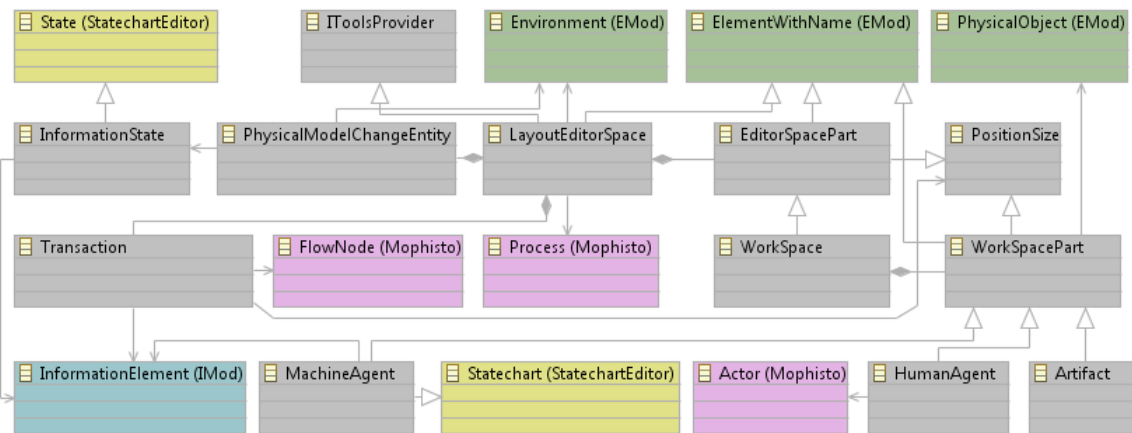
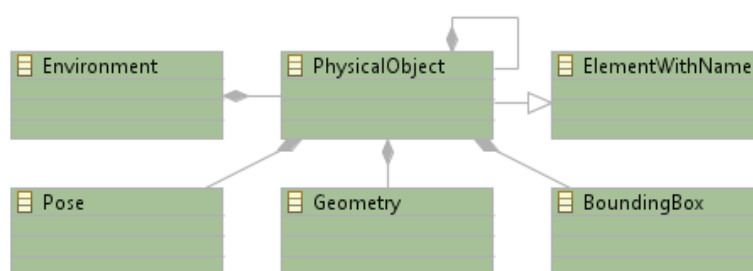

**Figure 45: Class Diagram of the LayoutEditor and interconnections to ShiATSu components**

All three are visual representing human agents, machine agents and artifacts respectively and they form a logical abstraction layer for combination of agents and artifacts from the Spatial Model with agents from the Collaborative Process Model (see chapter 4.5). *HumanAgent* instances are referencing instances of *Actor* which are corresponding to submodels of  $M_i$ . *MachineAgent* instances are referencing *InformationElements* of *IMod* and are *Statecharts* that can have multiple *InformationStates*. *InformationState* corresponds to the *IState* construct, described with this thesis' modelling method. *InformationState* references *InformationElement* as well, such that during modelling users can choose, whether they set up a simple one-state machine agent - directly referencing *InformationElement* instances, or a multifunctional machine agent with multiple *InformationStates*. Also part of the *LayoutEditorSpace* children are instances of the *Transaction* class, which represents an SA Transaction. *Transaction* references multiple *InformationElements* and two instances of *PositionSize* (as source and target). *PositionSize* defines the location (x,y) and seizing (width, height) of *EditorSpacePart*'s and *WorkSpacePart*'s icons for the 2D top view of the *LayoutEditor*. Since *WorkSpacePart* is referencing *EMod*'s *PhysicalObject* and inherits *PositionSize*, instances of *Transaction* may reference to *WorkSpacePart* instances, which have no *PhysicalObject* referenced. This is especially useful in early testing of positions without concrete bodies. *PhysicalModelChangeEntity*'s instances are defining the simulation schedule. This includes a list of applicable changes in the environment at one defined point in time, according to Environment Dynamics Scheduling (chapter 4.6.1.2.2).

### 5.1.2 EMod

The Environment Modeller EMod is a tree editor which enables to create and manipulate environment models via a GUI. EMod is part of the HAGGIS simulation platform that is developed within context of the e-Maritime integrated reference platform (eMIR) for e-Navigation.<sup>4</sup> EMod provides an interface to the HAGGIS data model. The HAGGIS data model incorporates standards for digital geographic information and geomatics that is covered by the technical standard committee ISO TC 211. For ShiATSu only a small subset of via-EMod provided data model is required, which is depicted on Figure 46.



**Figure 46: Class Diagram of a HAGGIS data model subset provided via EMod**

Instances of *Environment* represent a physical environment, which is a collection of *PhysicalObject* instances. A *PhysicalObject* can contain multiple other *PhysicalObject* instances. It has a *Name* (through inheritance of *ElementWithName*), *Pose*, *Geometry* and *BoundingBox*. The *Pose* is used to define an n-dimensional position in the *Environment* and corresponds to the *position* property of the Spatial Model (chapter 4.5.1.2.3). The *Geometry* corresponds to the *geometry* property of the Spatial Model and holds the graph structure to describe the geometry in local space (always relative to the pose). The *BoundingBox* represents an abstraction of the geometry's outer hull as a box shape. It is employed as a helper to accelerate collision detection.

### 5.1.3 IMod

The Information Modeller IMod is a visual diagram editor that provides a GUI to all information elements. *IMod* enables users to create, edit and delete information elements. Further, other components of ShiATSu are able to use/reference the stored information elements, meaning interlinking with *LayoutEditor* and *Mophisto*. Major classes of IMod are depicted in Figure 47. Instances of *InformationElement* represent the information elements. *InformationElement* inherits from EMod's *ElementWithName* class, thus providing a name attribute as String.

<sup>4</sup> <http://emaritime.de/>, visited 20.01.2016

Instances of *InformationElement* are 'stored' in an instance of the *InformationModel* class. Analogue to the *LayoutEditor's LayoutEditorSpace* class, the *InformationModel* class reflects the IMod's background, and a palette and property view for creating, editing and deleting compound children and referenced objects. The *Category* class is used as a visual structural element, to provide the possibility to categorize *InformationElement* objects.

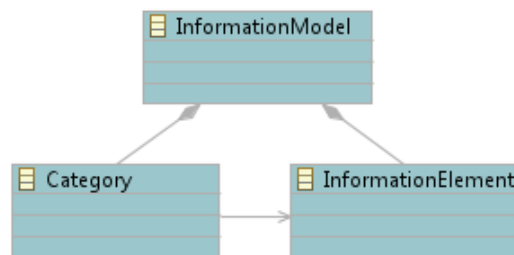

**Figure 47: Class Diagram of IMod's data model**

#### 5.1.4 Mophisto

The Maritime Operation Planning Tool Mophisto is visual collaborative process modelling application. It is part of the HAGGIS simulation platform and was initially developed as research prototype for modelling of Safe Offshore Operations (SOOP - an EFRE Project) (Sobiech et al. 2012; Pinkowski 2015). The Mophisto data model architecture is depicted in Figure 48. In its major parts, the Collaborative Process Model from this thesis can be represented with the Mophisto data structure. The class *Process* corresponds to the overall Collaborative Process Model  $M$  and the *Actor* class to the submodels  $M_i$ . *FlowObject* represents the elements of the set  $E$  and *ConnectionObject* represents an element in  $R$ . The subclass *Task* reflects the elements in  $E_{Task}$ . Mophisto is providing an abstract class *Event* that has multiple purposes for modelling offshore operations, e.g. sending of signals or communication between agents. In ShiATSu the *Event* class is used to represent generally team tasks corresponding to the elements in  $E_{Team}$ .  $E_{Team}$ 's elements are connected via  $R_{Synchronous}$ 's elements, which are corresponding to instances of class *MessageFlow* in Mophisto.  $R_{Sequential}$ 's elements are represented by class *SequenceFlow*. For ShiATSu, Mophisto's data model required an architectural extension to allow the annotation of information elements within task and teamwork elements. Therefore, relations to *InformationElement* (from IMod) forming Information Supply and Information Demand Sets (see chapter 4.2) were integrated into Mophisto's software architecture.

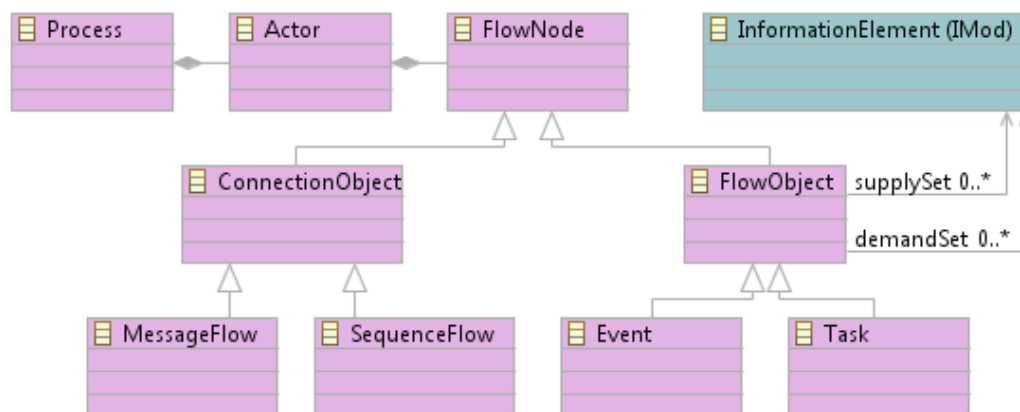

Figure 48: Class Diagram of relevant Mophisto classes with relation to IMod

### 5.1.5 StatechartEditor

The *StatechartEditor* is a visual diagram editor for simple Statecharts. Its purpose is to enable modelling of the states and state changes that are part of a machine agent, as elaborated with the *IStates* concept in the method. The design ajars the StateML, but abstracts from modelling runtime behaviour. A data model overview is given with Figure 49. The class *Statechart* reflects the diagram editor’s background, and a palette and property view for creating, editing and deleting compound children and referenced objects. It can contain multiple instances of class *State*. *State* is inherited by *InformationState* of *IMod* and is extended with references to class *InformationElement* in the *LayoutEditor* component. *States* hold their *Transitions*, which in turn define directedness from source *State* to target *State*.

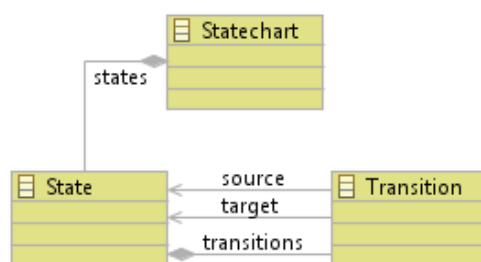

Figure 49: Class Diagram of StatechartEditor's data model

### 5.1.6 ModellingTools

The *ModellingTools* component assembles means that support the execution of the modelling method of this thesis. They are plugged-in the *LayoutEditor* in a way that they can be executed with having control over the Integrated Model via the *ITools* interface (inversion of control). There exist two main kinds of *ITool* implementations: the subclasses *WorkPlanner* and *WorkPlanVerifier*. *WorkPlanner* provides an occupancy grid, access to the Integrated Model

and an abstract method for execution of planning. Implementations specify how planning will be executed. The architecture foresees two exemplary planners, the *ContinuousPlanner* and the *WorkPlaceCentricPlanner*. Both *WorkPlanner* subclasses follow the optimization criteria for automated heuristical planning, as described in chapter 4.5.2.2.2.

The *WorkPlaceCentricPlanner* follows the idea of fixed work places for crew members as a central position for work (see chapter 2.21.1). Contrary, the *ContinuousPlanner* follows the idea that human agents always use information elements that are the closest to their spatial position. Created SA Transactions from planners are serialized after planning. The *WorkPlanVerifier* is a class that has methods to create dialogs for provisioning verification feedback to the GUI and a method that executes associated verification classes. The four verification classes are *ConsistencyVerification*, *IntervalVerification*, *HumanConflictVerification* and *HumanSatisfiabilityVerification*. These four classes implement the verification methods describe in chapter 4.5.2.2.4 on Work Plan Verification.

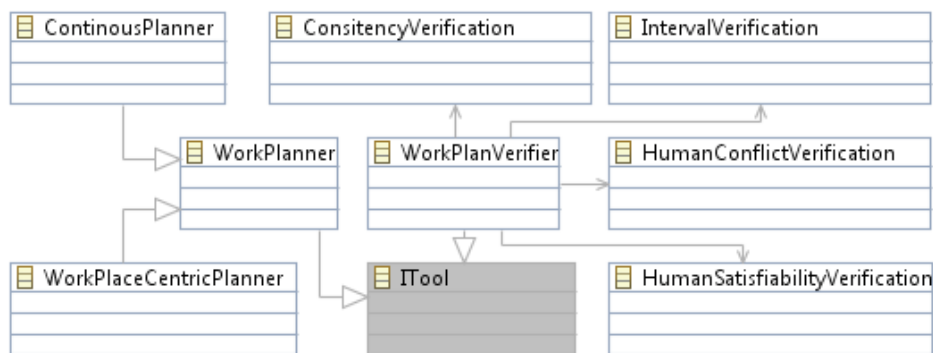

**Figure 50: Class Diagram of ModellingTools**

### 5.1.7 SimulationTools

The SimulationTools component assembles means to prepare the IM for execution and to execute the Resource Management on the IM. Figure 51 shows classes of the SimulationTools component. Again, the entry point for interaction with the LayoutEditor-provided data, like the IM, is the *ITools* interface, whose instances will receive the context data. The *SceneGraphVerifier* class implements the tool for Runtime Verification, as described in chapter 4.6.2 - Environment Verification. Therefore, it uses *PhysicalModelChangeEntity* instances from the IM, a *3DEngine* and an *OccupancyGrid*. It creates a test specimens and the work environment with the 3DEngine and generates the occupancy grids, which are exported to a user-defined destination. The *RMExecutor* implements the general Resource Management Execution algorithm. For traversal, a navigation graph (class *NavGraph*) is created from an

occupancy grid. The grid is created with a specimen of the human agents. The *Orientation* and *Traversal* classes implement the minimalistic and deterministic behaviour of the human agents for traversal and orientation towards information elements. Both alter an instance of the IM during runtime. The resulting *ExecutionDataSet* is used for analysis.

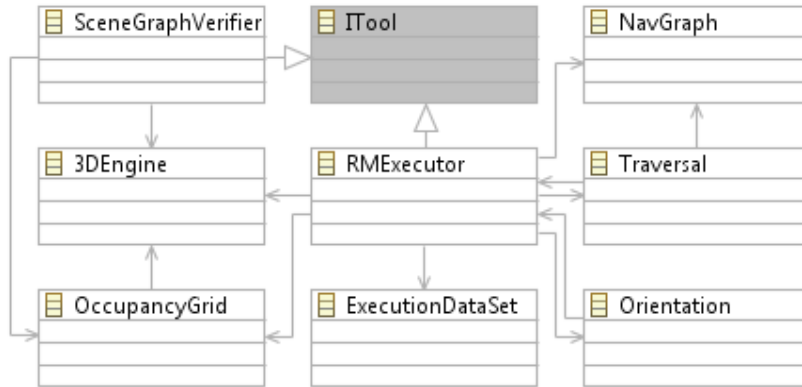

Figure 51: Class Diagram of SimulationTools

### 5.1.8 AnalysisTools

The AnalysisTools component assembles means to analyze the *IM* and the produced *ExecutioDataSets*, which were created during simulation, to enable the analysis step of this thesis' method. The *LMCAnalysis* class is triggered by the SimulationTools to create an *LMC* for each information element of a given SA Transaction. The LMCs are serialized and can be used by the Interference Detection (class *Interference*). *Interference* incorporates methods to parse LMCs and detect interferences according to the description in chapter 4.7.1 on Computational Analytics. The class *ReportCreator* is automatically called after a simulation run. Its methods allow creating a detailed and an aggregated view on execution statistics according to the description in chapter 4.7.2 on Assessment. The *3DViewer* is a tool for visualizing the work environment with all agents at a specified point in simulation time. Walked paths of human agents and their sensomotoric geometries are drawn into *3DViewer*'s canvas. A class diagram of the AnalysisTools is shown on Figure 52.

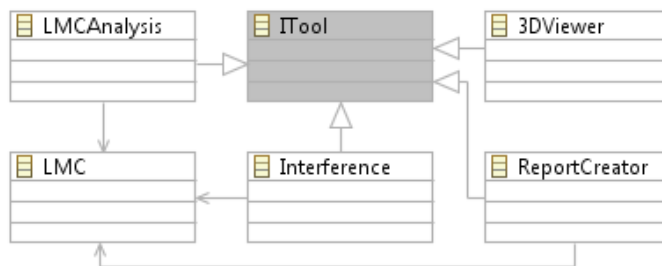
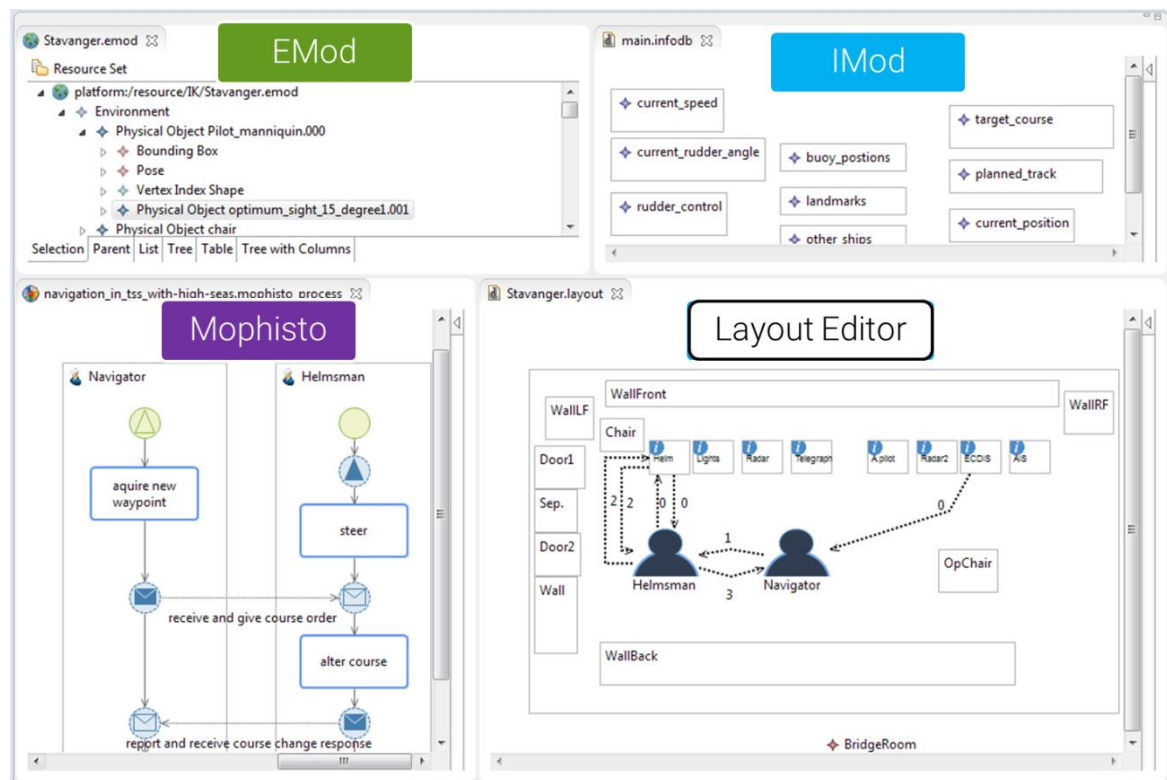

Figure 52: Class Diagram of AnalysisTools

## 5.2 Implementation

The prototypical implementation of ShiATSu is based on the architectural description in chapter 5.1 and will be set out, with this chapter. Therefore details on main functionalities of the software components are given.



**Figure 53: ShiATSu integrates EMod, IMod and Mophisto with means of the LayoutEditor. The LayoutEditor's content of the represents EMod 3D models in 2D top view, these models can be human agents, machine agents, artifacts or hull. Machine agents reference multiple information elements from IMod. Human agents reference an actor in a Mophisto Collaborative Process Model. Tasks, such as 'steer', are referencing information elements as supply or demand as well.**

The software prototype is implemented model-driven with the Eclipse Modeling Framework (EMF) and its Graphical Modeling Framework (GMF). EMF allows platform-independent description of software architectures and automated model code generation into the Java programming language over a so-called Generator Model (genmodel). The code generation results in functioning Java class bodies including setters, getters as well as user-defined

method heads. (Steinberg et al. 2008) This way of code generation is enhanced by EuGENia<sup>5</sup>, which is extending the genmodel's code generation annotations for visual components of GMF. In this way, it is possible to automatically generate rudimentary diagram editors within minutes. A rudimentary diagram editor can be enhanced programmatically and over EMF's plug-in functionality via extension points (an abstraction of OSGi - a dynamic module system for Java).

### **5.2.1 LayoutEditor's Implementation**

The LayoutEditor's GUI is depicted at the bottom right of Figure 53. There, machine agents are portrayed in a square with a blue information symbol. Human agents are portrayed with a human silhouette. Kinds of hull elements and artifacts are symbolized as blank squares. Dotted arcs in-between human and machine agents symbolize SA Transactions and are marked with a number, which stands for the corresponding temporal *interval*. All elements on the LayoutEditor are creatable via a pallet on the right (hidden on figure). The LayoutEditor implements an import wizard, which allows creating an initial layout from an EMod file. Changes in the LayoutEditor's diagram can be synchronized back to the EMod model via a context menu. Further, the context menu displays tools, which implement the *ITool* interface. The property view of the LayoutEditor (not visible on figure) allows linking multiple Mophisto diagrams and IMod information models to the layout file. With a click on a diagram object the property view allows to edit the object, which is a standard functionality of EMF editors. There, human agents' actors are linked to the Mophisto process. Machine agents' information elements are addable via the property view as well. State charts of Information States can be created within the StatechartEditor (compare chapter 4.5.1). If state charts are used to express machine agent's functionality, then an initial state (start of simulation) and a current state (changed during simulation) are settable in the LayoutEditor as well.

### **5.2.2 EMod, IMod, Mophisto and StatechartEditor Implementation**

The EMod, IMod, Mophisto and StatechartEditor were implemented model-driven. Therefore, the architectural component diagrams were transformed into EuGENia-processable source code and enriched with annotations that define the building blocks of the particular editor. Figure 54 shows the complete definition of IMod. @gmf and @namespace tags are commands to EuGENia which define the automated source code generation. Properties can be defined in

---

<sup>5</sup> The website <http://www.eclipse.org/epsilon/doc/eugenia/> gives an overview and application example of EuGENia; visited 20.01.2016.



following parentheses. E.g. it's defined for elements of the class *InformationElement* to have a label, which has the content of the attribute *name*, which is inherited from *ElementWithName*. On the upper left part of Figure 53, consequent result of this IMod definition in EuGENia is shown. Information elements are displayed as rectangle. In the source code of Mophisto, the EuGENia figure attribute was linked to a Scalable Vector Graphic (SVG), which is automatically aligned on the resulting editor's surface. The architectural extensions of information supply and information demand sets were implemented into Mophisto by adding reference definitions to Mophisto's EuGENia source in the *FlowObject* class (e.g. `ref InformationElement[*] informationSupplySet;`).

```

1. #include "platform:/resource/EMod/EMod.yml"
2. Model IMod {
3.   @namespace ( prefix := "IMod", uri := "http://www.offis.de/haggis/IMod" )
4.   package imod {
5.
6.     @gmf.diagram(onefile := "true", diagram.extension := "infodb" )
7.     class InformationDB extends ElementWithName {
8.       val Category[*] categories;
9.       val InformationElement[*] informationElements;
10.    }
11.
12.    @gmf.node(label := "name", label.placement := "internal", figure := "rectangle")
13.    class Category extends ElementWithName {
14.      ref InformationElement[*] informationElements;
15.    }
16.
17.    @gmf.node(label := "name", label.placement := "internal", figure := "rectangle")
18.    class InformationElement extends ElementWithName {
19.    }
20.  }
21. }

```

**Figure 54: EuGENia model-driven definition of IMod**

### 5.2.3 ModellingTools Implementation

The ModellingTools provide elements to the LayoutEditor's context menu. On right-click on the LayoutEditor context menu elements of the *WorkPlanners* and *WorkPlanVerifiers* are selectable by the user. The two implemented planners use the Integrated Model over the *ITool* interface. Figure 55 shows the difference between the two planners in a simple example: Information elements demanded and supplied by the OOW are existent on Displays 1, 4 and 5. Whereas the workplace-centric planner forces the human agent to supply information elements to Display 1, the continuous planner results in an SA Transaction with Display 5.

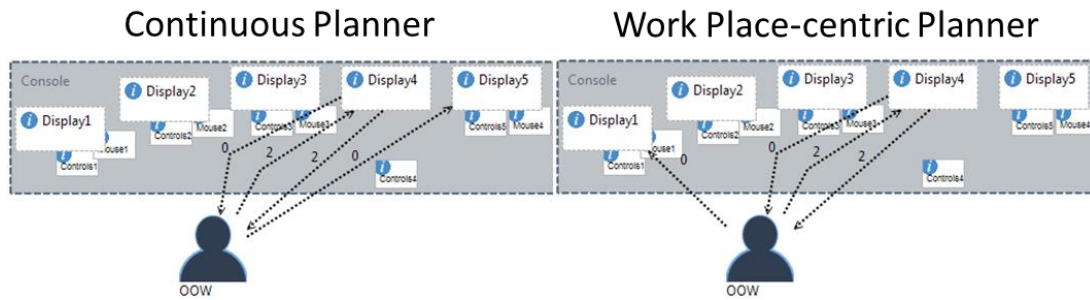

**Figure 55: Difference between two implemented Work Planners**

The *WorkPlanVerifier* is available via the context menu as well. Its four associated verification class instances are called to evaluate the selected Integrated Model. Their callback is an object with references to multiple *ElementWithName*, which allows backtracking and can be used to create a textual description which is pointing the user to problems in the model encountered during verification. Callbacks' textual descriptions are compound displayed on a dialog, when all verification processes did finish. An exemplary resulting dialog is shown in Figure 56. There, two textual descriptions are outputs of the *ConsistencyVerification* and the *HumanSatisfiabilityVerification*.

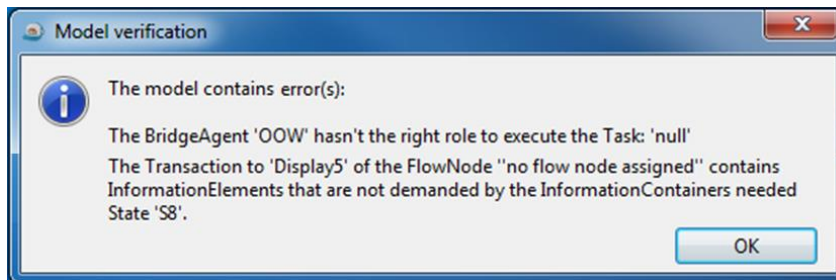
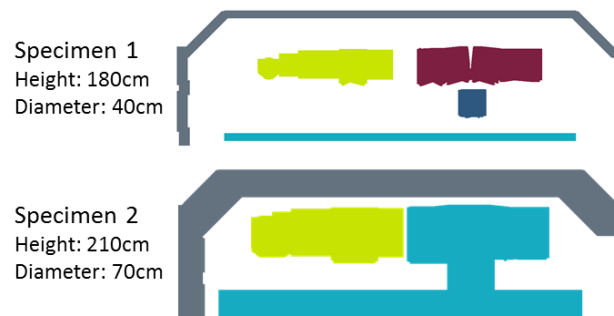

**Figure 56: Pop-up dialog displaying results of the WorkPlanVerifier**

### 5.2.4 SimulationTools Implementation

The two key-parts in the *SimulationTools* component are the *SceneGraphVerifier* and the *RMExecutor*, which can both be executed from the *LayoutEditor*'s context menu. The *SceneGraphVerifier* therefore accesses the layout model and creates 3D instances out of every single *WorkSpacePart* - more precisely every *WorkSpacePart*'s associated *PhysicalObject*. Within the ShiATSu prototype, implemented geometries of test specimen are hardcoded. There exist two test specimens, one with 180cm height and 40cm in diameter, and another defined with 210cm height and 70cm diameter. Figure 57 depicts the outputs of an Intra-Scene Graph Verification executed with the *SceneGraphVerifier* with the two specimens: It's a figure on which for each occupied area a different color is used to enable detection differences

quickly. In a comparison of both pictures, a user could detect a problem caused by the operator's chair, which blocks a passage way between RADAR and a wall.



**Figure 57: Intra-Scene Graph Verification with two alternative test specimens**

The *RMExecutor* is driving the execution of SA Transactions. Its methods implement the generalized algorithm explained with Figure 39. Again, the execution can be triggered from the *LayoutEditor*'s GUI. In the implementation an *OccupancyGrid* is generated from the IM initially. To calculate the traversal effort, the shortest path is used, that is required to transact the information elements. The shortest path is calculated on the base of a *NavGraph*. The *NavGraph* is an 8-neighbourhood graph, created out of the *OccupancyGrid*. The shortest path is then calculated on the *NavGraph* via the A\*-algorithm (Hart et al. 1968).

The cost for postural change is rudimentarily implemented, as a reorientation of sensomotoric geometries towards an information supply or information demand. This is neglecting changes like banding or kneeling. The reorientation of sensomotoric geometries is implemented with the *lookAt()*-method of Java 3D, which is typically used for virtual-camera reorientation towards a defined target. In the implementation the sensomotoric geometries of the active agent are considered as 'camera', which re-erects towards the SA Transaction's opposite agent.

The matching situation calculation is implemented with simple Java *ArrayLists*, which provides functions to add, remove and retain *InformationElements* to mimic mathematical operations, such as *union* and *intersection*.

As a simplified measure for cost of transaction efforts, ShiATSu counts the amounts of SA Transactions and the amount of *IState* changes that are required to get from one state to another state. Such a state change is triggered by a SA Transaction.

### 5.2.5 AnalysisTools Implementation

The ShiATSu implementation of the AnalysisTools provides two kinds of artifacts to the user - the reports, generated by the *ReportCreator* and the *3DViewer*. Excerpts of the *ReportCreator* output is shown on Figure 58, where high level and low level reports are shown. In the actual implementation, on the high level report for every human agent walking distance and head rotation are summed up, as are values for traversal effort and postural change effort. Additionally, superfluous information elements are shown. On the low level, for every SA Transaction groups of measures are shown. E.g. for *start\_system* the agent had to walk 2.05 meters and rotate his head about 58° degree, there was no IG<sup>+</sup> or IG<sup>-</sup> and the Tversky ratio model similarity (RMS) hence is 1 (Denker et al. 2014; Tversky 1977). While hovering over an SA Transaction representation, LMCs are shown to the user. Detected inferences would be highlighted. The reports are marked up in HTML5, which is created by the *ReportCreator*. For visualization of the charts a JavaScript library called highcharts<sup>6</sup> was employed.

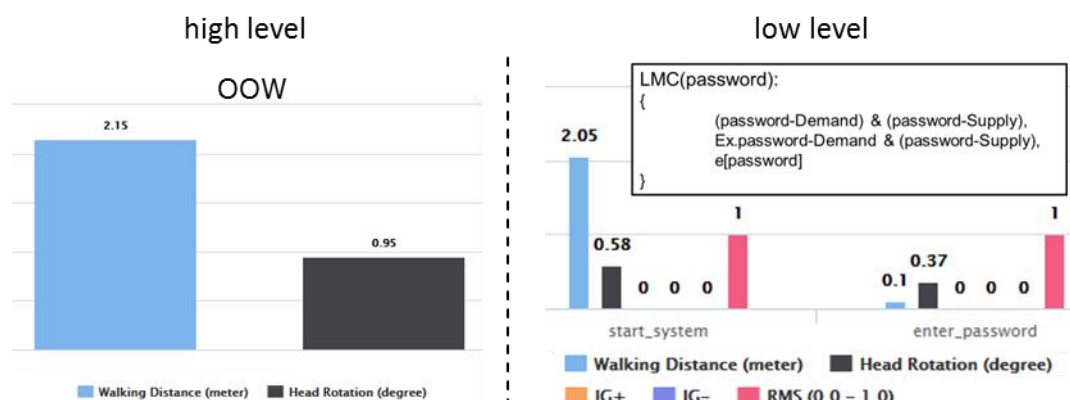
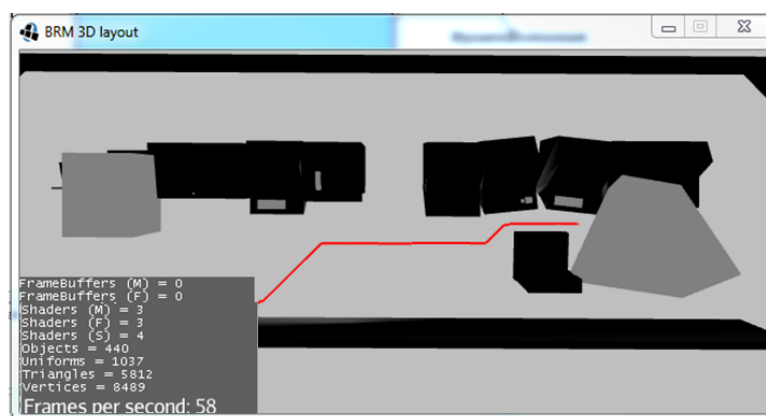

**Figure 58: Output of ReportCreator - high level and low level report**

For visual inspection during runtime of a simulation, the AnalysisTools contains a prototypical *3DViewer*. This is a program, which facilitates an IM's file (LayoutEditor-file) and an interval number. Based on these two inputs, the *3DViewer* can hook into the simulation during runtime and visualize the current work environment. On Figure 59 the layout from Figure 53 is visualized with the *3DViewer*. The program is capable of displaying any given physical object. The viewer's camera can be moved and reoriented with mouse and keyboard. Traversed paths of a human agent can be displayed as a red line, which depicts the center of an agent's body. Display of sensomotoric geometries and paths can be toggled on/off. On the bottom left computational metrics with information of the loaded IM are displayed. This is a standard

<sup>6</sup> <http://highcharts.com/>, visited 20.01.2016  
110

feature, which comes with the JMonkeyEngine<sup>7</sup> that was extended and used to implement the 3DViewer.



**Figure 59: 3DViewer showing the traversed path (red) of the Navigator (compare Figure 53) towards the ECDIS (right, with sensomotoric geometry)**

### 5.3 Conclusion

ShiATSu supports all phases of the presented method. The IM can be fully modelled, simulated and analyzed with the support of the presented implementation. For modelling, ShiATSu provides diagram editors to define a layout that represents the IM and is linked to Mophisto models (CPMs), Information Models (IEs), linkable to EMod and state chart models (SMs). For planning of work execution, two planners have been implemented. The verification of the work plan can be done automatically with ShiATSu's ModellingTools. During setup of the model the LayoutEditor allows to integrate 3D environments and to schedule their dynamics. The SimulationTools allow verifying the dynamic environment with an implementation of the test specimen approach and of course to simulate the execution of the work plan. Cost functions for quantitative measurement of the execution have been implemented with the A\*-algorithm to calculate the shortest path, a 3D reorientation of the sensomotoric geometries and counting the amount of SA Transactions and required state chart's transitions (*IState*). Within the analysis step ShiATSu supports the elicitation of LMCs and the creation of reports. Both outputs are presented with the output of HTML reports.

<sup>7</sup> <http://jmonkeyengine.org/>, visited 15.01.2016



## 6 Evaluation

In previous two chapters, a solution and a prototypical implementation was presented, which ought to support the method as an answer to the overall research question “How to assess ship bridges for crew’s information supply and demand in navigational situations during design time?”. In this chapter the method and ShiATSu are jointly applied in testing three research hypotheses. Meanwhile these applications progress, it is demonstrated, whether the research question can genuinely be answered with the presented solution. The abstract procedure for evaluation is testing three hypotheses, which allow to proof or falsify the solution’s ability to answer the research question and objectives. The three hypotheses are:

1. Differences between Work Spaces are representable and measurable.
2. Work Space Layout has an Effect on Situation Awareness.
3. Collaborative Process has an Effect of Situation Awareness.

All three hypotheses are tested by application of the method and the prototype in combination with results from simulator studies, which were executed in the framework of the European FP7 project CASCADE (Model-based Cooperative and Adaptive Ship-based Context Aware Design).

### 6.1 Differences between Work Spaces are representable and measurable

The hypothesis claims that differences in the spatio-temporality of information supply and demand are generally representable and measurable and that this difference can be identified by comparison between two or more work spaces, both with this thesis’ solution.

To proof or falsify this claim, a simulator study has been designed; whose outputs were forming the context of use. The context of use was taken for elicitation of sound Collaborative Processes. The Collaborative Processes and a Spatial Model of the simulator were then modelled, simulated and analyzed with the method for assessing the spatio-temporal information supply and demand and ShiATSu. In the following, details on study design, method application and results are provided.

#### 6.1.1 Study Design

The study considers two alternative ship bridge designs, which form the conditions, as depicted with the table in Figure 60. Both designs were implemented into an adaptable ship

bridge simulator, whose adaptivity describes the ability to change the displays' content and to create arbitrary compilations of a display's content. The bridge designs differ in allocation of different information contents on the five adaptive displays of the simulator.

	Baseline or Testing?	Classical Bridge	CASCADE Bridge
Condition 1	Baseline	Yes	No
Condition 2	Testing	No	Yes

**Figure 60: Conditions of the simulator experiment**

### Simulator Design

In the **first condition**, classical bridge's displays were installed. There were double (left and right) RADAR and ECDIS (Electronic Chart Display and Information System) displays and a single so-called Conning display (center). The setup is depicted in Figure 61 during a simulation run with Master and Pilot.



**Figure 61: Simulator Suite during simulation with Master (left) and Pilot (right) during start of passage in Kiel harbour. Video cameras capture their interactions and display content.**

The **second condition** incorporates a concept of a novel display for sharing information amongst the crew - the so-called "Shared Display", which was developed by professional human factors engineers in cooperation with seafarers during the CASCADE project. In contrast to condition 1, in condition 2 the left ECDIS display was replaced with a mock-up of the Shared Display. The Shared Display is an extended ECDIS, which allows its users to touch-draw on a sea chart, annotate notes to locations and to exchange information with a Pilot's Portable Pilot Unit (PPU). The mock-up of the Shared Display is shown on Figure 64.



## Scenario Design

Both ship bridge conditions were used within the same simulation scenario: The execution of a (pre-planned) passage from Kiel harbor (Baltic Sea, Germany) to Skagen harbor (Kattegat/Skagerrak region, Denmark) with the 160x27m-sized bulk carrier M/V AAL GLADSTONE. Due to time limitations, the study was restricted to observe two phases of the passage: the Master-Pilot exchange on the moored ship (at berth), and the passage out of the Kiel berth into the Baltic Sea at Kiel-Friedrichsort's lighthouse. The passage is sketched on the map of Figure 62 with the initial traffic situation and a roughly sketched route (green). The scenario setup was revised by a professional ship simulator instructor from the nautical training academy at the University of Applied Sciences Flensburg, who advised on realistic traffic, weather and inter-ship communication conditions. In addition, the instructor simulated communications with/from Vessel Traffic Service (VTS) and foreign ships steering, which were fully simulated during simulation runtime. The reason for choosing these two phases was that they were both said to be action-loaded, at least in comparison to a long ocean passage. Further, the simulator technically provided solely maps of the Kiel region, which led to reduced cost in setup.



**Figure 62: A map of the simulation scenario with traffic setup in Kiel harbour**

As depicted on Figure 62 the ego ship AAL GLADSTONE is starting the passage close to its berth in front of the "Schwedenkai", where the Master-Pilot exchange is done. On starting deberthing, the ferry Stena Germanica is arriving from sea to berth at "Schwedenkai". Meanwhile, Asian Breeze is coming from the lock at a speed, that there will be an encounter with the ego ship. At the same time, Hooge will encounter with Asian Breeze and the ego ship. There is a seismic survey running by Hoppe close to Friedrichsort. Bro Anna encounters the ego

ship in-between lock and lighthouse. Color Fantasy is incoming from Baltic Sea and will encounter at the survey operations, which causes a complex situation. The passage between lock and lighthouse was advised to be tricky due to traffic dense, but said to be overall realistic and not too stressful. On situation resolution, at the height of the lighthouse, the simulation finishes after an estimated runtime of 45 minutes. Besides these six potential encounters, the waterway is restricted with buoys, a channel and fairway-restricting shallow water areas (Friedrichsort).

### **Participants**

“On board of the ego ship”, operating in the simulator suite, a Master and a Pilot were instructed to sail safely and efficient out of the harbour, while obeying all general and local rules, and the rules of good seamanship. There were 4 Masters and 2 Pilots invited for overall 4 simulator runs. In contrast to Masters (one run each), Pilots were each taking part in two runs. A priority in the simulator runs was on using currently active seafarers, and it was also essential that they had experience with systems and equipment of the simulator, so that any performance variation that could be accounted for learning would be reduced. Thus either Captains or Chief Officers were acquired, who are also familiar with navigation under pilotage. The Masters were all non-German sourced from Mastermind Shipmanagement, with experience on Raytheon equipment, whereas the Pilots were German and sourced from Nautischer Verein zu Kiel, which lead to communication done in English.

The average age of the 4 Masters was 43.8 (range 31 - 57), and the average years spent at sea was 25.5 years (range 7 - 40). There were 3 Captains and 1 Chief Officer. The experience of the seafarers was mostly on general cargo carriers, bulkers and container ships. Two of the seafarers were Polish, one was Montenegrin and one was Bosnian-Herzegovinian. The Pilots were 46 and 40 years old, and had worked at sea 28 years and 20 years respectively. The trainer was 54 years old and had worked at sea for 36 years.

### **Data Collection**

The simulator experiments were filmed using multiple video cameras as depicted with Figure 63. This multi-camera approach was adopted to record the precise interactions of the seafarers. Each of the five displays had a camera in front, capturing the probably dynamic informatory content on the screens of the MFCs (camera 1-5). A camera in front, above the simulator’s external vision system (camera 6), was filming into the direction of the wheelhouse poster. There was another camera on the ceiling (camera 7), filming participants from above. The last camera was positioned in the back of the simulator (camera 8), whose footage was

used during the procedure interviews. All cameras were capturing both audio and video. Camera 8 was equipped with an additional microphone, which enabled to capture full communication between the participants.

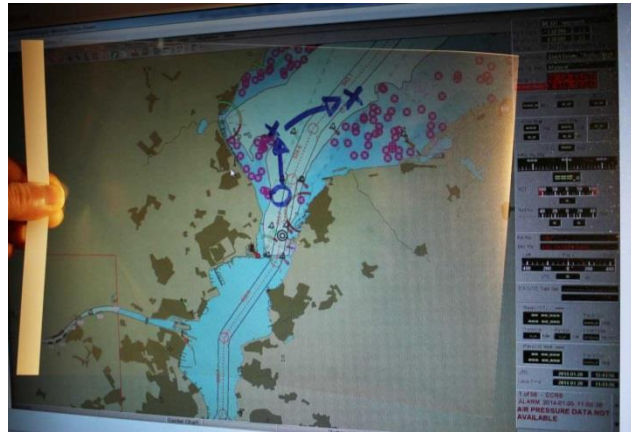

**Figure 63: Camera placement in the simulator suite**

## **Procedure**

In all four runs the Master-Pilot exchange was the same without any additional tools. The changes between the two conditions applied to the passage phase. In the first condition, the Pilot received a PPU to use (which is State of the Art), and the Master was asked to navigate out of port as normal. In the second condition, the PPU was removed and the Shared Display mockup was introduced to allow Pilot and Master, using white-board pens, to annotate over the most left ECDIS display of the simulator. To replicate what it might look like if the Pilot had exchanged route information with the vessel, a route was also shown on the Shared Display. Figure 64 shows the Shared Display mock-up while removing the white-board pen slide after a simulation run.

Subsequent to simulator runs, Masters and Pilots were taking part in a procedure interview on the interactions during the simulator run. The interviews' aim was to make interactions explicit. This means, to gain insight of the reason leading to an interaction, identifying information elements, which are relevant in the situation at hand, and filtering irrelevant interactions. Especially, participant's gaze on information elements was of interest, since no eye-tracking technology was available, that would have allowed to technically analyzing that data. During the interview, the Master's and Pilot's common simulator run, captured on camera 8, was shown and the participants were asked to explain their interactions and relevant information elements. The participants' commentary was captured as an additional audio line to camera 8's playback with Camtasia - a screen capturing software.



**Figure 64: Shared Display mockup – an ECDIS with a slide annotated with white-board pens (blue) and an exchanged route (red)**

Afterwards, on the basis of all procedure interviews, Collaborative Process Models were created and linked to an Information Model. The Collaborative Process Models were revised by a former seafarer, with 4 years of navigational experience, to check for CPMs' conformance with the data collected during simulator runs. The Information Model was created by analyzing the simulator system, and enriching additional information elements, which were solely part of communication between participants during simulator runs. The simulator's geometrical structure was measured and modelled as a Spatial Model with Blender<sup>8</sup>, whose 3D models are importable into EMod. The reason was that no technical drawings of the simulator suite existed.

Finally, the method described with this thesis was executed, as described in the following.

## **6.1.2 Method Execution**

The method was executed in its three steps, from Modelling, over Simulation to Analysis.

### **6.1.2.1 Modelling**

Firstly the Integrated Model was elicited. This meant to create the Information Model, Spatial Model and Collaborative Process Models out of the simulation data. Then SA Transactions were planned manually according to the interactions perceived from simulation run captures.

#### **Information Model**

Firstly IMod was used to model extractable general information elements from displays of the simulator. Therefore, video footage of the display filming cameras was considered. Figure 65

---

<sup>8</sup> <http://blender.org/>, visited 20.01.2016

depicts an excerpt of the information elements within categories. Here, the categories represent functional components of the bridge system. E.g. GPS information was shown on both ECDIS and RADAR display, both having the same GPS receiver as source. Thus, the information element was generalized, since the demand of that information elements could be fulfilled on both displays. There were overall more than 80 information elements identified. Information elements, which were used in this evaluation, are shown in Appendix A.2.

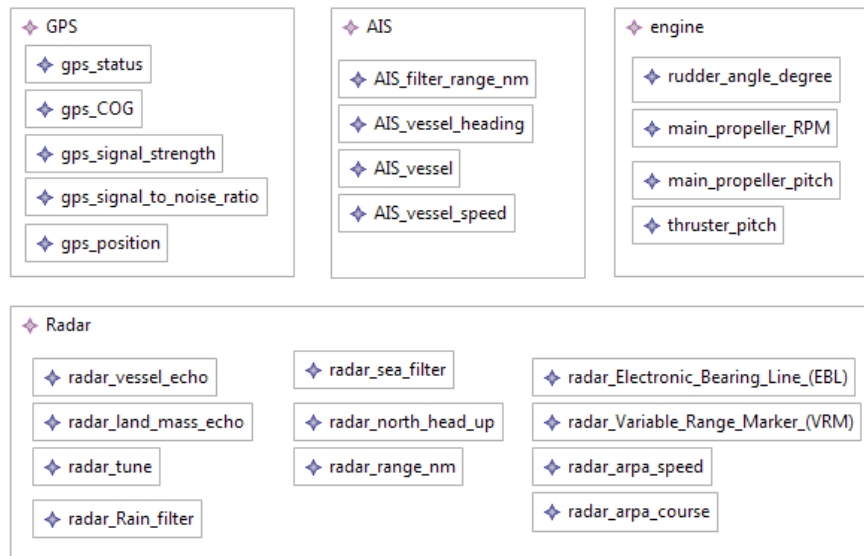

**Figure 65: Excerpt of the Information Model in IMod**

### **Collaborative Process Models**

For elicitation of CPMs, three hours of commented video footage from procedure interviews has been firstly reviewed and then been modelled as CPMs with ShiATSu's Mophisto. For this modelling the simulation run has been sub-divided into different processes, which were different in interactions that have been observed during the simulation run. These are 8 processes which comprise namely,

- a Master-Pilot exchange,
- a course change,
- an encounter situation,
- an encounter with a jetty,
- the identification of a vessel leaving the lock,
- crossing with lock traffic,
- entering of restricted waters near the lighthouse, and
- passing the lighthouse strait.

It was found that there were alternative processes executed amongst the participants, such that 5 alternatives could be identified. Namely these findings are 2 alternatives of Master-Pilot exchange, 2 alternatives of the encounter situation, 2 alternatives of the encounter with a

jetty, 2 alternatives of identification of a vessel leaving the lock, and 2 alternatives of entering of restricted waters near the lighthouse. It is to mention, that there are was no interaction modelled using the white-board pen feature, for the sake of comparability of assessment results. Hence, all CPMs were used during the assessment of both conditions.

Figure 66 shows one of the 13 CPMs: Initially the Master detected an oncoming ship and asked the Pilot, whether he has established VHF communication with the ship. The Pilot then started establishing the connection to agree on “red-to-red”; afterwards the Pilot translated the agreement into English. Then the Master detected a jetty as potential danger. He checked distance to jetty via ECDIS and their common Closest Point of Approach (CPA). Then the Master informed the Pilot of his ship’s safe distance preference. Successively the Pilot measured the distance to the breakwater with RADAR’s Electronic Bearing Line (EBL). In the end, the Pilot and Master agreed on changing the course. Yellow boxes annotate comments about the simulator run, to provide readers with hidden semantics of the CPM. All 13 CPMs are depicted in Appendix A.1.

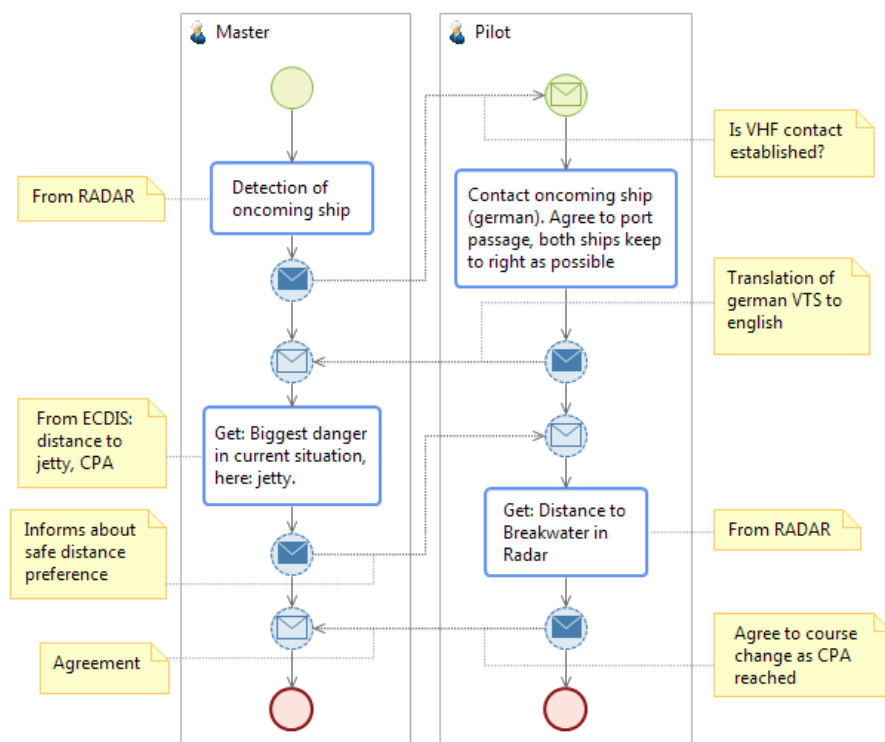

**Figure 66: A CPM for encountering with jetty after keeping clear of Stena Germanica with annotated commentaries from video footage**

All information elements mentioned in the description match to information elements in the Information Model, and were inter-linked with them in each CPM.



## Spatial Model

The Spatial Model was built out of measurements taken in the simulator suite, which went directly into the 3D model depicted on Figure 67. The model includes sensomotoric geometries of the displays and levers, which were used during the simulation run. Further, mannequins represent the human agents, which have 15° optimum sight sensomotoric geometry (see chapter 2.2.3) as their child.

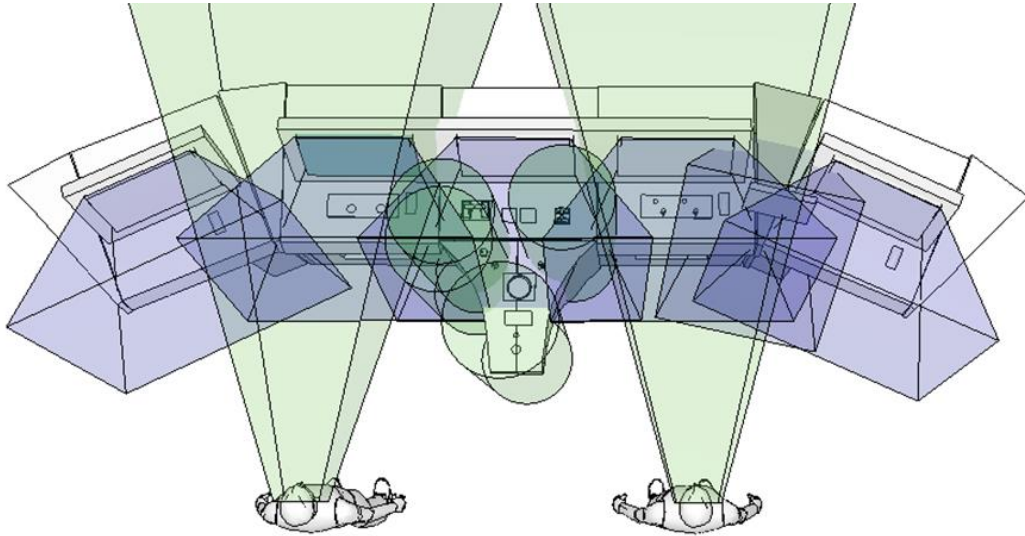

**Figure 67: 3D model with sensomotoric geometries of the simulator. The model is used as input to the LayoutEditor**

During the simulation run it became apparent, that the multifunctionality of the displays was not used by the participants. They tended to use the default configuration. Thus, in the Spatial Model, *IStates* were superfluous.

The 3D blender model was imported into ShiATSu with EMod. The LayoutEditor automatically generated a skeleton of a bridge layout of the imported EMod file, which is depicted in Figure 68. Size and position of the machine agents do not always equal the 3D model object's data, due to technical limitations in the EMF implementation. Thus, e.g. orientations of machine agents are not presented, as visible in comparison of Figure 67 and Figure 68. Groups of machine agents can hence be represented cluttered, as depicted under Conning Display. The LayoutEditor model was then enriched with information elements of the Information Model. E.g. Display 1 supplies 34 information elements in condition 1.

For condition 2 the Spatial Model was adopted accordingly. The Shared Display is replacing the left ECDIS. The Shared Display supplied information elements of the ECDIS and the RADAR due to a so-called RADAR-overlay functionality of an ECDIS' chart.

## Evaluation

The two human agents, whom are standing in front of the console, according to their estimated starting position in the simulator runs are not depicted. All 13 processes were linked together to the layout model, the left human agent works as a Master, and the right human agent works as a Pilot, both referencing the CPMs.

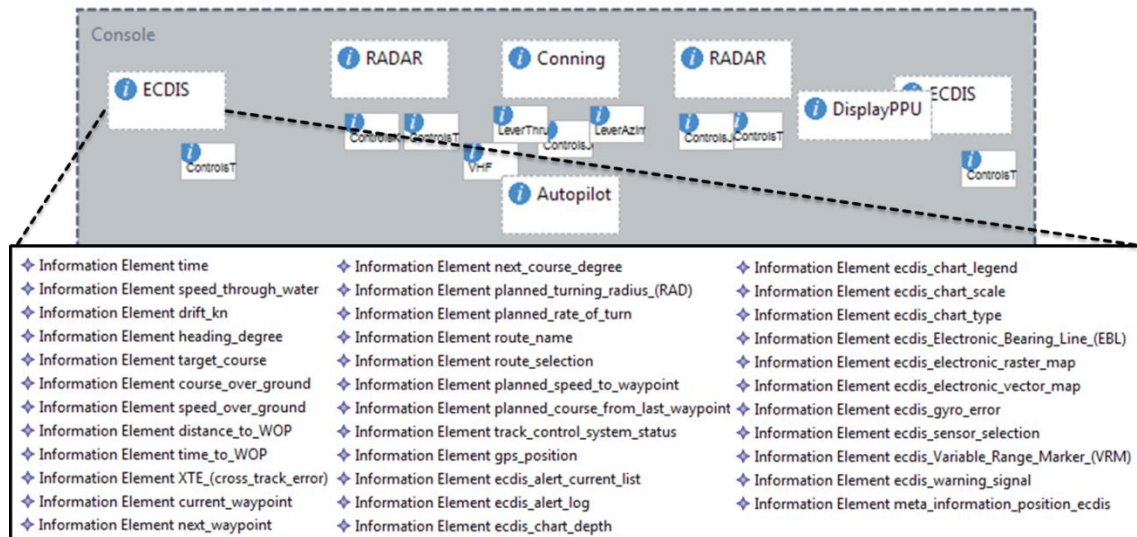

**Figure 68: Abstract visualization of the simulator's ship bridge in the LayoutEditor with referenced information elements of left ECDIS in condition 1**

## Manual Planning

To model the simulator run, manual planning of SA Transactions was done on the layout with the LayoutEditor in both conditions for all 13 CPMs. E.g. for the jetty encounter CPM shown on Figure 66 in condition 1 overall 11 SA Transactions were observed between 2 human agents and 5 machine agents. In condition 2, overall 9 SA Transactions were observed between 2 human agents and 2 machine agents. SA Transactions averagely transact more information elements than in condition 1. There the Pilot demands information elements that are supplied

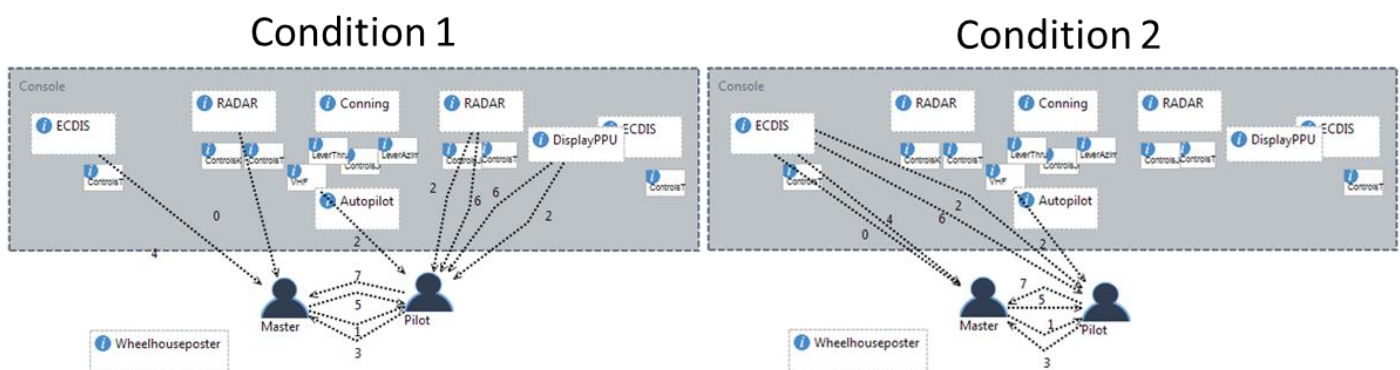

**Figure 69: Condition 1 vs. Condition 2 of encounter with jetty**



on different machine agents (intervals 2 and 6). Layout Models of the jetty encounter are depicted in Figure 69.

After planning, work plan verification has been executed with ShiATSu's ModellingTools. The models were all tested for consistency to CPMs and their Intervals were set correctly. Due to non-existence of *IStates*, there were no conflicts between human agents. Every supply and demand of information elements by human agents was satisfiable.

### **6.1.2.2 Simulation**

On the basis of the verified LayoutEditor models, the simulation step was executed. During simulation setup the environment's hull was disregarded since no ergonomic assessment of distances between console and hull was required. The human agents' bodies were 1.80m in height and had a maximum diameter of 70cm. Since there were no dynamics in the environment, scheduling of the environment dynamics was not performed. To verify the imported 3D model, runtime verification has been performed. Its resulting occupancy grid is depicted on Figure 70.



***Figure 70: Excerpt from the occupancy grid generated during runtime verification***

Finally, ShiATSu was used to execute the work of the human agents defined in the Integrated Model via the SA Transactions. After simulation the paths of human agents were visualized with the 3DViewer. All paths were reflecting the IM's SA Transactions. Figure 71 shows a screenshot of encountering the jetty in condition 1.

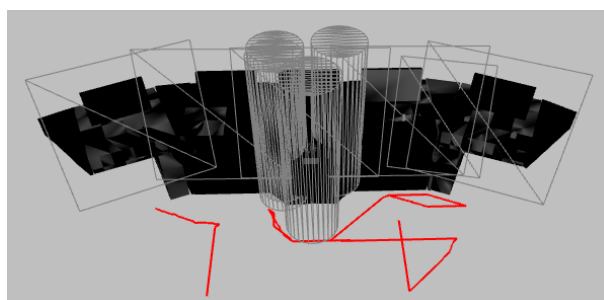

***Figure 71: Screenshot from 3DViewer visualizing the simulator bridge with sensomotoric geometries and human agents' paths***

### 6.1.2.3 Analysis

The Computational Analytics step has been executed for every simulation run automatically by ShiATSu and resulted into LMCs, which did not yield interferences, and costs in each a high level and low level report. Subsequently a multi report assessment has been executed for both conditions.

#### Life and Motion Configurations

Figure 72 shows a listing with an excerpt of the LMCs in condition 1. Besides the pure LMCs, ShiATSu provides meta information, which allow backtracking into the layout model (via Interval) and the CPM (via Task). Further, the direction of the SA Transaction/information flow (lines 60 and 66) is shown. The LMCs (lines 62-64 and 68-70) show the information demand of the Master for 3 information elements *rudder\_angle\_degree*, *target\_course* and *speed\_over\_ground*. *speed\_over\_ground* couldn't have been fulfilled at the Conning. This led to transacting with ECDIS, which supplies *speed\_over\_ground*. From line 68-69, it's deducible that the change from Conning to ECDIS required a position change (compare with Figure 41). Not fulfilled demand in line 70 was already fulfilled in line 62.

59.	...
60.	Master <- Conning
61.	Interval: 8 Task: show_rudder_and_engine_config
62.	{ (rudder_angle_degree-Demand) & rudder_angle_degree-Supply, e[rudder_angle_degree] }
63.	{ e[target_course] }
64.	{ speed_over_ground-Demand & !Ex.speed_over_ground-Supply }
65.	
66.	Master <- ECDIS
67.	Interval: 8 Task: show_rudder_and_engine_config
68.	{ (speed_over_ground-Demand) & speed_over_ground-Supply, e[speed_over_ground] }
69.	{ e[target_course] }
70.	{ rudder_angle_degree-Demand & !Ex.rudder_angle_degree-Supply }
71.	...

**Figure 72: Excerpt of LMCs in Condition 1**

#### Multi Report Assessment

Besides LMCs, a report was created for each condition. Figure 73 shows the high level report output of both conditions. It is perceivable, that condition 2 has in all cases lower values in comparison to condition 1. Human agents traversed 19.24 meters less in condition 2 (aggregated 68.50m vs. 49.26m) and also had less postural changes in condition 2 by 9380 degree (aggregated 150.70 deg/100 vs. 141.32 deg/100, which almost equals 26x 360°).

Based on these indicators and under consideration of safety and efficiency aspects, this assessment leads to the conclusion, that condition 2 is favored over condition 1, since it enables execution of the processes at less cost.

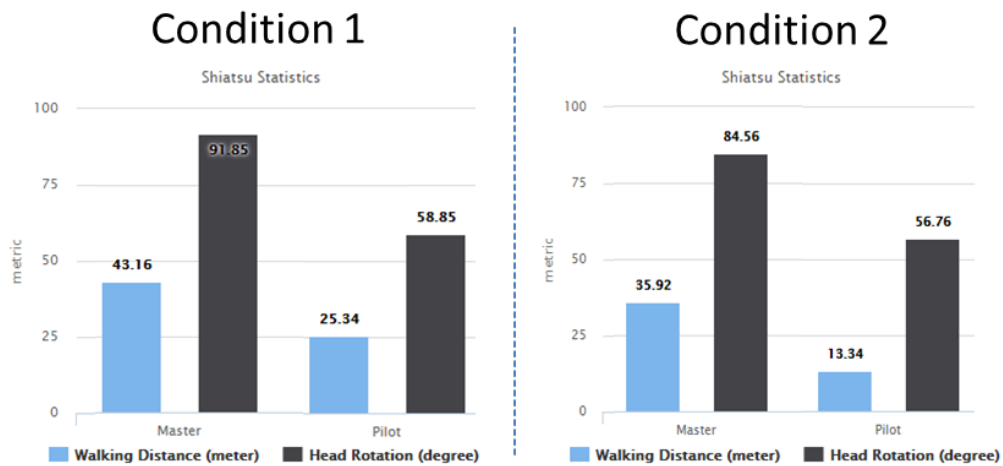

**Figure 73: High level comparison of both conditions**

### 6.1.3 Results

The hypothesis has been evaluated with two alternative work spaces (condition 1 and 2). The work spaces differed in positioning of information elements, whereas physical structure of the simulator remained the same. CPMs used in the evaluation did consider information elements, which are supplied and demanded in both work spaces.

The elicitation of CPMs focused on gathering qualitative data, in sense of the amount of different CPMs, instead of quantitative data, with a huge amount of repetitive processes. To encounter quantitative shortcomings, experienced participants were selected. Potential failure prevention in modelling of CPMs has been done by validation with a professional seafarer, before the method has been executed.

Over method execution, the representability of alternative Spatial Models, CPMs and their influence on SA Transactions has been successfully shown. Through application of the artifact ShiATSu, it has also been shown that the alternative work spaces lead to result in different cost for traversal and postural changes. Hence, differences in the spatio-temporality of information supply and demand are representable and measurable. ShiATSu provides means that allow comparing the measures. The claim is proven.

## 6.2 Work Space Layout has an Effect on Situation Awareness

This hypothesis claims that the spatio-temporality of information supply and demand has an effect on human agents' Situation Awareness. This claim is linked to the proof of hypothesis 1, that differences between work spaces are representable and measurable. The claimed effect

should condense into the ShiATSu results. Meaning, that changes of allocation of information elements are identifiable in ShiATSu's analyses output.

To proof or falsify this claim, subsequently to the simulator runs of the evaluation of hypothesis 1, a questionnaire has been executed with the 6 participants of the simulator study. The claim is defined to be proven, when the questionnaires' results correlate to the measurements of evaluation 1. In the following, the questionnaire and results of this evaluation are described.

### **6.2.1 Questionnaire**

Besides capturing the simulation runs (described with hypothesis 1), a questionnaire was executed with the participants of the simulator study. Firstly, the questionnaire's aim was to survey how the participants subjectively perceived the scenarios with the design idea developed in CASCADE in comparison to classical ship bridges. Secondly, the questionnaire was meant to gather challenges seafarers face when facing similar situations in real life. In this thesis' evaluation the focus is on the first part: The participants' perceptions were inquired via questions on subjective judgement of simulation performance, a comparative feedback on the condition 2 simulation runs, and an observatory expert judgement.

#### **Subjective Measurement of Simulation Performance**

To measure how participants believed they had performed during a simulation run and how they perceived the other participant involved, they had to respond to four 7-point Likert scale questions:

- How difficult do you think the exercise was? (1= Difficult, to 7=Easy)
- How was your communication with [other participant] (1= Very Poor, to 7=Very Good)
- How well do you think you personally did on exercise? (1= Very Badly, to 7=Very Well)
- How well do you think you did as a team on exercise? (1= Very Badly, to 7=Very Well)

#### **Subjective Comparative Feedback on Condition 2**

Further, to gather the impact of condition 2 with the Shared Display, the participants were inquired to give a comparative feedback, which may allow deriving their judgement on Situation Awareness. The responses were gathered by asking questions about the additive feature of the Shared Display. The two features were considering (1) shared routes, which were transferred from the PPU onto the Shared Display and (2) changing the waypoints of a shared route on the Shared Display. For these two features, the following, mostly 7-point Likert scale and one multiple choice, questions were asked:

- What do you feel the overall impact of this feature might be? (1=negative to 7=Positive)
- To what extent do you feel this feature might have an impact in terms of Safety? (1=negative to 7=Positive)
- To what extent do you feel this feature might have an impact in terms of Efficiency? (1=negative to 7=Positive)
- To what extent do you feel this feature might have an impact in terms of Communication? (1=negative to 7=Positive)
- To what extent do you feel this feature might have an impact in terms of Master Pilot exchange speed? (1=negative to 7=Positive)
- To what extent would you like to see this feature on board ships?
  - I would really not like to see it (1)
  - I would not like to see it (2)
  - I'm neutral (3)
  - I would like to see it (4)
  - I would really like to see it (5)

### **Observatory Expert's Judgement**

Besides seafarers as participants, the simulator instructor from the nautical training academy, who ran the simulator runs, was engaged to give his expert judgement on his perception of participants' performance and condition 2. Therefore, the expert was inquired to judge on the simulation performance of each participant in all 4 sessions (both conditions 1 and 2). Further, the instructor was also asked to give his feedback on condition 2, during all simulation runs.

### **6.2.2 Response Analysis**

Obviously, the simulator exercises were not designed, to draw statistical conclusions on the performance. Since simulator runs, which involve a large number of variables, require a large sample size. This was not possible to achieve. Further reuse of a Pilot in two sessions, and reuse of the Instructor for all sessions leads obviously to learning effects, even when learning effects were intended to be reduced with the help of the described experiment design. This should be cautiously noted, since e.g. the Instructor gave higher scores to condition 2. In the following, the results of subjective simulator performance inquiry and subjective comparative feedback are described.

### **Simulation Performance**

Average performance scores of subjective simulation performance are provided with Figure 74. The averages for all responses on difficulty (condition 1 & 2, n=7) was 4.5, whereas the instructor rated 4.0 in each run and seafarers found condition 2 more difficult. Meaning,

## Evaluation

seafarers perceived difficulty of condition 2 increased, while simulation procedure remained the same.

Seafarers responded slightly improved communication in condition 2 (avg. difference 0.17), whereas the objective Instructor averagely scored distinct better communication in condition 2 (avg. difference 1.5).

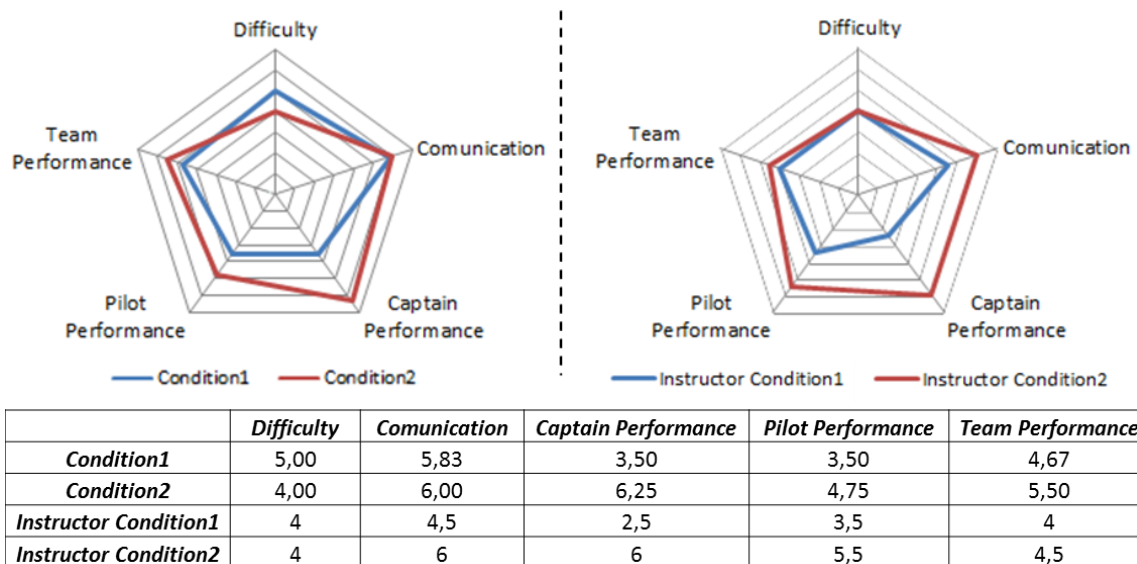

**Figure 74: Averages of subjective performance measurements of Captains, Pilots (left), and Instructor (right) as 7-point polar diagrams with data table**

Master/Captain Performance rated better average performance on work execution in condition 2, by rating 'well' performance (6.25). This is also reflected in Instructor's scoring. Condition 1 is rated with an average score of 3.5 amongst seafarers and Instructor.

Almost similarly, Pilot performance in condition 2 surpasses performance in condition 1 (3.5 vs. 4.75). But, differences between scores of Pilots between conditions were 1.25 - hence, with less expression.

Team performance amongst seafarers and Pilots was rated higher in condition 2 as well with a difference of 0.83 to condition 1. Again, the instructor accounted better team performance in condition 2, as well.

### Comparative Feedback on Condition 2's Features

The ideas, sharing the routes (Feature 1) and changing the waypoints (Feature 2), received quintessentially positive feedback. Masters, Pilots and the Instructor rated the route exchange feature more positive than the State of the Art PPU solution, with an average rating of 5.57. The feature for changing waypoints via touch display was even received more positive with an

## Hypothesis 2: Work Space Layout has an Effect on SA

average rating of 6.57 across all participants (1=negative, to 7=positive). All four seafarers gave the touch-moveable waypoints feature consistent ratings of 7 for Safety, Efficiency, Communication and Performance, indicating noticeable enthusiasm for this idea amongst those using the Raytheon ECDIS on a regular basis.

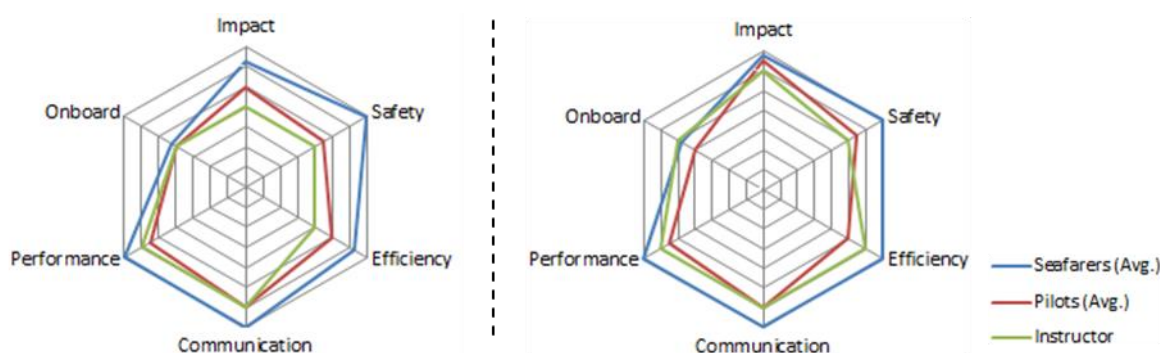

Feature1	<i>Impact</i>	<i>Safety</i>	<i>Efficiency</i>	<i>Communication</i>	<i>Performance</i>	<i>Onboard</i>
<b><i>Seafarers (Avg.)</i></b>	6,25	7,00	6,25	7,00	7,00	4,25
<b><i>Pilots (Avg.)</i></b>	5,00	4,50	5,00	6,00	5,50	4,00
<b><i>Instructor</i></b>	4,00	4,00	4,00	6,00	6,00	4,00
Feature2						
<b><i>Seafarers (Avg.)</i></b>	6,75	7,00	7,00	7,00	7,00	4,75
<b><i>Pilots (Avg.)</i></b>	6,50	5,50	5,00	6,00	5,50	4,00
<b><i>Instructor</i></b>	6,00	5,00	6,00	6,00	6,00	5,00

**Figure 75: Averages of subjective comparative judgement for Feature 1 (left, shared routes) and Feature 2 (right, changing waypoints) with data table**

Averagely, across all participants for both features, the highest ratings have been given to Communication, with an overall average of 6.57, closely followed by Performance (6.43). Both items were rated equally for the two features. Also Efficiency (5.57 vs 6.28) and Safety (5.86 vs. 6.0) received overall positive scores, which were slightly higher for Feature 2.

All participants responded in favor to see both features onboard by scoring positive with 4.36 (average across both features). It's noticeable that none of the responses were negative.

### 6.2.3 Results

Within the presented questionnaires' results no evidence could be found to falsify the hypothesis that "Work Space Layout has an Effect on Situation Awareness". Due to the small sample size and explanatory proof cannot be derived. However, the measures from subjective measurement of simulation performance correlate to the results of this thesis' method with ShiATSu from evaluation of hypothesis 1 (chapter 6.1). There the high level report shows that

human agents have less cost (less traversal, less postural change, less SA Transactions) in condition 2. The subjective performance measurement results indicate that participants rated condition 2 better, as well. Thus, on a systemic level ShiATSu results seem to reflect reality in cross comparison of Communication, Captain Performance, Pilot Performance and Team Performance with the ShiATSu metrics on traversing, postural change and amount of SA Transactions.

Interestingly, the results in difficulty, which was rated higher in condition 2 and makes a distinction to the other items rated positive, reflects findings between Situation Awareness and Workload described in literature: There is a relation found between Situation Awareness and Workload. That relation may correlate positively or negatively depending on the magnitude of Workload for an operator to be situational aware (Parasuraman et al. 2008; Mouloua & Gilson 2001).

The results of this hypothesis evaluation do not proof a causal relation, but may contribute to a proof, e.g. that the Work Space Layout has not only a positive correlation on crews' Situation Awareness. The hypothesis' claim about the existence of a correlation between Work Space Layout and Situation Awareness is proven.

### **6.3 Collaborative Process has an Effect on Situation Awareness**

The hypothesis claims that differences in-between multiple Collaborative Processes have an effect on human agents' Situation Awareness. This claim is linked to the proof of hypothesis 1, that differences between work spaces are representable and measurable. The claimed effect should condense into the ShiATSu results. Meaning, that changes of Collaborative Process Model are identifiable in ShiATSu's analyses output.

To proof or falsify this claim, two cognitive walkthroughs have been designed and executed for the process of sharing a route. A cognitive walkthrough is a methodology for evaluation of user interface designs early in the design cycle, which asks one or a group of users to assume to execute work with the system, this can also be a prototypical mock-up (Polson et al. 1992). Therefore, detailed procedures are used to force simulating a user's problem solving process, which is gathered through dialog and allows to check user's goals and memory content leading to the next correct action (Nielsen 1994).

Users' consensus about the process gathered during the walkthroughs went into the context of use, together with a bridge system. Two alternative configurations of the bridge system



were supposed to force alternative outputs in the cognitive walkthroughs. Based on the context of use, the two pairs of Collaborative Process and a Spatial Model were modelled, simulated and analyzed with the method for assessing the spatio-temporal information supply and demand and ShiATSu. Analogue to hypothesis 2, participants have been queried for subjective measures of Situation Awareness in the aftermath of the two walkthroughs. The hypothesis set to be falsifiable by showing non-correlation between measures from questionnaire and ShiATSu output. In the following, details on the cognitive walkthroughs, method application, the questionnaire and results are provided.

### **6.3.1 Study Design**

The study presented in this evaluation is a part of a greater scale study with several steps, where each step aimed to evaluate a new feature of an Integrated Navigational System. Some features were a virtual notepad, route exchange tool, display mirroring, a chart annotation tool, a watch hand-over perspective, console adjustments (tiltable display and height adjustment) and a virtual checklists tool. These features were developed with industry partners over the course of the European CASCADE project.

Within the here considered study, two cognitive walkthroughs have been executed, which were supposed to explore and gather feedback on the novel route exchange feature. The advantage of taking the cognitive walkthrough methodology was to not having to simulate a whole passage in real-time, as done for evaluation of hypothesis 1 and 2. This shrunk down the execution time of an entire port-to-port voyage to 2 hours, including watch hand-overs, pilotage, equipment failure, and docking, concentrating on the novel features.

The walkthroughs have been executed with a configurable ship bridge simulator at hand, which implements the novel feature(s). In the following simulator design, participants involved, procedure design and the questionnaire are described.

#### **Simulator Design**

The bridge simulator system (depicted on Figure 76) had two configurations. The first configuration includes State of the Art “means” for exchanging route information - the baseline condition. This essentially is the Pilot’s PPU, which had the original route implemented, and a standard ECDIS System, both systems of industrial project partners. Further, both systems exist today in the daily work under pilotage on board of seagoing commercial ships.

## Evaluation

---

The second configuration includes the route exchange system that has been designed in CASCADE - the CASCADE condition. The system provides an integration of route data exchange in-between PPU and ECDIS over a Wi-Fi network. The bridge system therefore is technically extended with a Wi-Fi Access Point allowing the PPU tablet to connect.



**Figure 76: Simulator suite with the CASCADE ship bridge providing both baseline and CASCADE Condition**

### Data Collection

Within the simulator suite, during the cognitive walkthrough, audio and video capturing was used to record the interactions and discussions during execution of each walkthrough. Audio was ought to be helpful for discussions in-between participants during the walkthrough to later reason the correct modelling of Collaborative Processes. Video feeds were recording movements of participants simulating work execution. A questionnaire was used to elicit demographics and responses to Situation Awareness measures for each feature. Positioning of the cameras is shown on Figure 77.

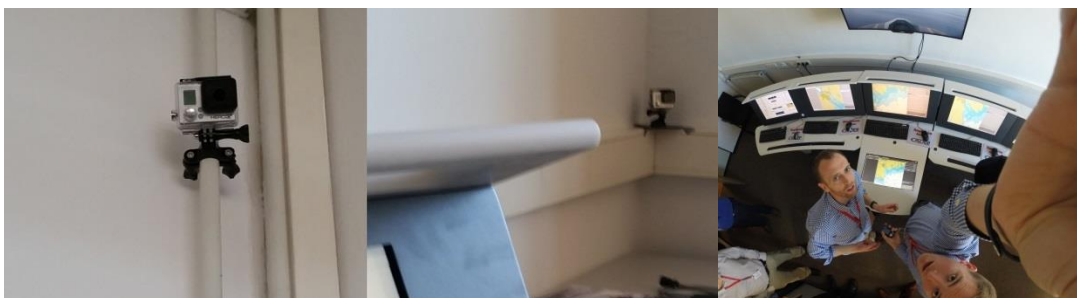

**Figure 77: Cameras setup in the upper left, lower right and ceiling of the simulator suite**

## **Participants**

Similar to the previous hypothesis, a qualitative approach was fostered to evaluate this third hypothesis. Experienced and currently active seafarers, working as Senior Officers, Junior Officers, Cadets, Pilots, and nautical training Instructors, were invited as participants. Due to the location of the simulator system, German Seafarers and Pilots were invited for the walkthroughs.

Overall nine participants took part in the walkthroughs, eight of them were males. There were four Pilots, one Captain, one 3<sup>rd</sup> Officer, one Cadet and two Instructors (previously seafarers). Participants' age ranged mostly (n=6) between 20 and 40 years. The participants worked on container ships (n=4), pilot boats (n=2), high speed ferries (n=1), chemical tankers (n=1) and general cargo carriers (n=1).

## **Procedure Design**

The considered steps in this evaluation are part of a 23-step guided cognitive walkthrough. The walkthrough is starting with Pilot's arrival in step 1, before de-berthing in an arbitrary harbour. The guide intends to cover bridge processes, in whose baseline and CASCADE condition were intended to cause distinct process execution for each of the novel features, till berthing in the aftermath of an ocean passage in step 23.

To evaluation hypothesis 3, steps 3 and 4 of the guide are considered here, which are depicted with the table on Figure 78. The reason for choosing the route exchange as subject of evaluation was that evaluation 2 already yielded positive feedback on the condition. But, in evaluation 2 feature-dependent Collaborative Processes and feature-dependent adjustment of Collaborative Processes to Spatial Model's changes were neglected. In steps 3 and 4, participants were asked to do a cognitive walkthrough for exchanging the intended route out of the ship's berth and discussing their actions and information (supplied and demanded) with other participants.

First, each step of the guide has been executed in the baseline condition. The representatives of each system manufacturer (bridge and PPU) explained the functionalities of the simulator's baseline configuration. Participants were encouraged to explore the system intensively to find their way to add the route, which was pre-implemented on the PPU, to the ECDIS system. Afterwards the group of participants executed the walkthrough jointly and discussed a unified way how Master and Pilot would collaboratively process the route exchange.

## Evaluation

Step #	Task to be completed	Baseline condition	CASCADE condition
1	Pilot arrives on board	Complete pilot embarkation checklist on paper	Complete pilot embarkation checklist on Shared Display
2	Captain tells Pilot ship characteristics	Pilot looks at pilot card at back of the bridge	Pilot looks at pilot card perspective on Shared Display
3	<b>Pilot shows captain the route out of the harbour</b>	<b>Pilot shows route on ECDIS screen</b>	<b>Route share on ship's ECDIS</b>
4	<b>Captain adjusts passage plan</b>	<b>Adjusts based on discussion with Pilot</b>	<b>Adjust based on shared route from PPU</b>
5	Captain told that parts for bridge window wiper repair were not delivered. Captain takes note.	Captain has to remember to tell next OOW	Captain makes a note about wiper on the Shared Display notepad
...	...	...	...

**Figure 78: Excerpt from the Cognitive Walkthrough guide, with route exchange feature relevant steps 3 and 4**

Second, the guide has been executed in the CASCADE condition. The representatives introduced the novel features and the participants were encouraged to explore their way to exchange a route between PPU und ECDIS. Figure 79 shows a picture of the introduction of the route exchange feature at the central console of the bridge. Again, the participants had to execute the cognitive walkthrough and to discuss a unified way how Master and Pilot would collaboratively process the route exchange. Further, participants received a questionnaire, which asked to respond to subjective queries on their perceived Situation Awareness for features in each step of the guide.



**Figure 79: Introduction of the route exchange feature to participants at the central console**

Afterwards, on the basis of all collected data of all cognitive walkthroughs, Collaborative Process Models were created and linked to an Information Model. The Collaborative Process Models were revised by a former seafarer, with 20 years of navigational experience, and the manufacturers' representatives to check for CPMs' conformance with the data collected during the walkthroughs and the systems' intended use. The Information Model was created by analyzing the simulator system, and enriching additional information elements, which were solely part of assumed communication, discussed between the participants during the walkthroughs. The ship bridge simulator's geometrical structure was received as Solidworks<sup>9</sup> 3D model from the industrial designer, which would form the Spatial Model. The Solidworks model was imported into Blender<sup>10</sup>, whose 3D models are importable into EMod.

Finally, the method described with this thesis was executed, as described with chapter 6.3.2.

### Questionnaire

To gather feedback on the overall bridge and PPU system and on individual features, participants were asked to respond to a questionnaire.

		Worse than conventional tools			No difference			Better than conventional tools				
		-5	-4	-3	-2	-1	0	+1	+2	+3	+4	+5
Step #	Task to be completed	SCORE										
1	Pilot arrives onboard											
2	Captain tells pilot ship characteristics											
3	Pilot shows captain the route out of the harbour and describes conditions - traffic, weather etc											
4	Captain adjusts passage plan											
5	Bridge phone rings. Captain told that parts for bridge window wiper repair were not delivered. Will have to wait till next port. Captain takes note.											

**Figure 80: Questionnaire excerpt: Querying comparative feedback for each step**

#### **Comparative Feedback on CASCADE Condition's Features**

During the cognitive walkthrough participants were asked to give feedback on each feature considered in the guide's steps. The feedback was given on an 11-point scale from -5 (worse than conventional tools) to +5 (better than conventional tools), asking for relative rating of CASCADE features in comparison to conventional means. Figure 80 shows an excerpt of the query. The intention was twofold: First to identify whether features were perceived as helpful

<sup>9</sup> <http://www.solidworks.com/sw/products/3d-cad/packages.htm>, visited 20.01.2016

<sup>10</sup> <http://blender.org/>, visited 20.01.2016

and second to provide a reminder of the feature for queries on Situation Awareness. The queries on Situation Awareness were to be completed after the walkthrough of the CASCADE condition.

**Comparative Feedback on Route Exchange**

The questionnaire distinguished Situation Awareness-related queries of all features generally into the categories *bridge tools* and *PPU tools*, whereas the route exchange feature was queried in the category of *PPU tools*, since the route exchange is technically initiated on the PPU. The queries did ask the participants for their estimation of influencing parameters of Situation Awareness, as depicted on Figure 81. These parameters are *physical effort*, *mental effort* and *increase in safety*, on whose feedback could be given again on an 11-point scale from -5 (will make things worse) to +5 (will make things better).

Please rate the new **PPU tools** that were demonstrated on the following dimensions. For each dimension, circle a number in the box that corresponds to your answer:

	Will make things worse					Will make no difference			Will make things better		
23. Physical effort	-5	-4	-3	-2	-1	0	+1	+2	+3	+4	+5
24. Mental effort	-5	-4	-3	-2	-1	0	+1	+2	+3	+4	+5
25. Increase in safety	-5	-4	-3	-2	-1	0	+1	+2	+3	+4	+5

26. Do you think the PPU design you have seen is an overall **improvement** over PPU designs commonly available now?

- <sup>1</sup> No      <sup>2</sup> Yes      <sup>3</sup> N/A (not familiar with PPU design)

27. Do you have any other comments about the new **PPU**, including any improvements?

**Figure 81: Questionnaire excerpt: Querying feedback on PPU tools**

It's assumed that low physical and mental efforts imply faster execution times leading to faster buildup of Situation Awareness. The questionnaire tested, whether the participants perceived an *improvement* through the PPU tools at all. Further, *comments* on shortcomings and improvements were gathered amongst the participants.

**6.3.2 Method Execution**

The method was executed in its three steps, from Modelling, over Simulation to Analysis.

**6.3.2.1 Modelling**

Again, firstly the Integrated Model was elicited. Therefore, the Information Model was extended, and the Spatial Model and Collaborative Process Models created out of the data

collected. Then SA Transactions were planned manually according to the interactions discussed during the cognitive walkthroughs.

### **Information Model**

IMod was used to setup the Information Model. Therefore, the Information Model from evaluation of hypothesis 1 was reused. Solely minor additions needed to be made to the Information Model. These additions are information elements that are required to execute the route exchange in the CASCADE condition. They are modelled in the category “route exchange” in the *IMod* model depicted on Figure 82, and their usage fares by definition with the content of the Collaborative Process Models and the Spatial Models.

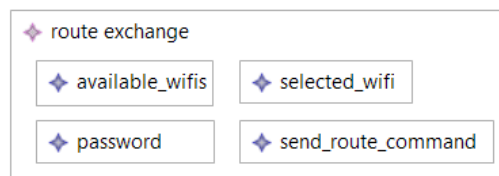

**Figure 82: Route exchange feature extensions to the Information Model in IMod**

### **Collaborative Process Models**

For each condition, the CPMs for route exchange have been created on the basis of both two hour recordings. Firstly, the recordings have been reviewed and then corresponding CPMs have been setup with ShiATSu.

As shown on Figure 83, the introduction of the new route exchange feature resulted in two different CPMs. In both conditions participants agreed on a distinct process start from other steps in the guide and to start with a warm greeting. In the baseline condition, with the State of the Art tools, participants agreed, that the Pilot would first receive ship’s current position and future waypoints from his PPU. Then the Pilot would tell the next course to waypoint 1, which is received by the Master, who enters it into his ship’s ECDIS. After having entered waypoint 1, the Pilot tells waypoint 2 position, which is again entered into ECDIS by the Master. This would repeat, till all of Pilot’s waypoints are added into the ECDIS. The Master then checks the route and discusses it with the Pilot. The process ends. The CPM on Figure 83 is an example for this “manual” route exchange with 5 waypoints.

In contrast, in the CASCADE condition, the Master would tell the Pilot his ship’s Wi-Fi credentials. To exchange the route the Pilot selects the Wi-Fi on his PPU, enters the password. On entering the password, the route is transferred to the ship’s ECDIS. The Master acknowledges the route reception and goes into the ECDIS’ route manager to select the route.

The Pilot tells the course to the next waypoint. Master and Pilot can start discussing the exchanged route. The process ends.

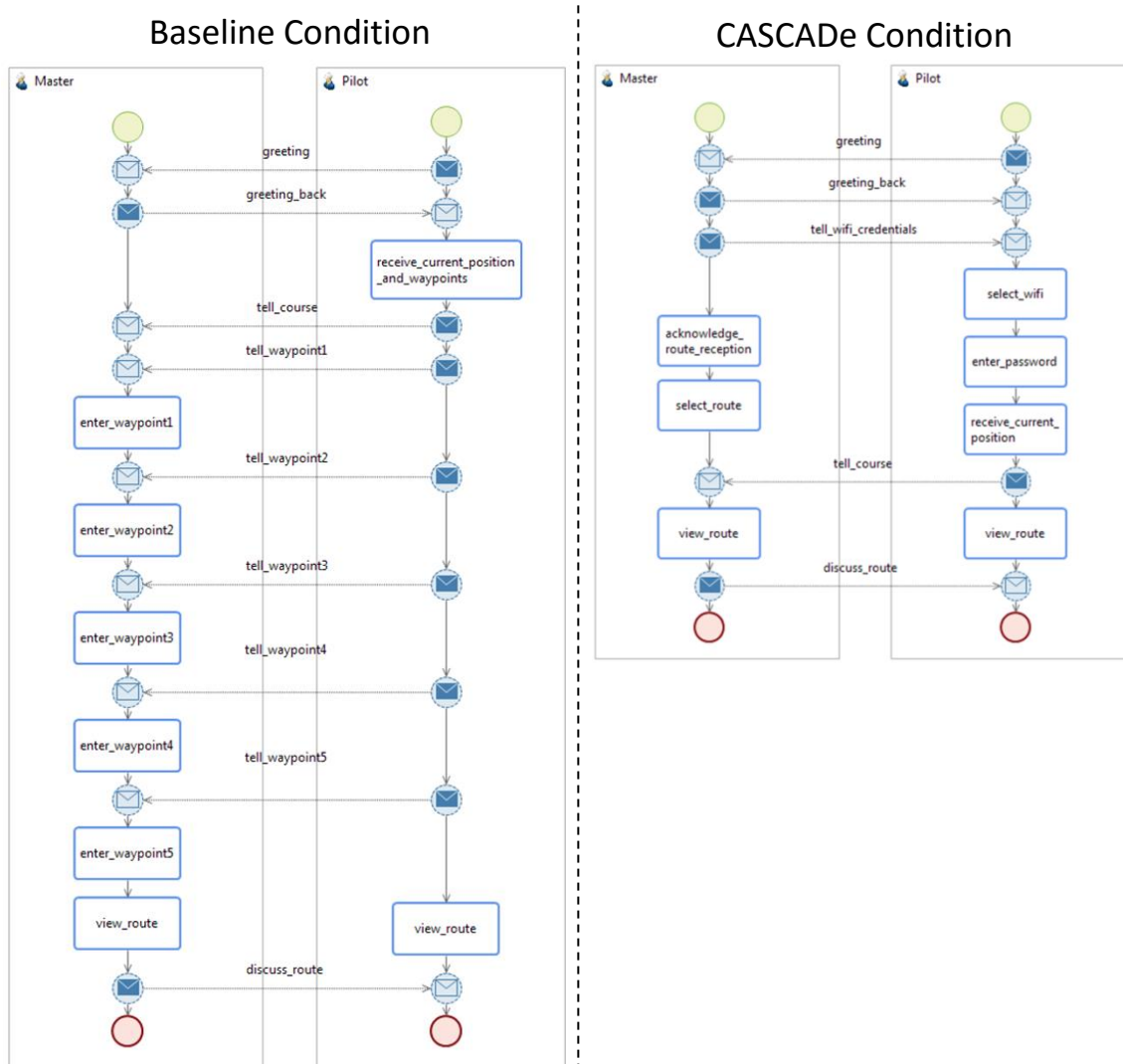

**Figure 83: CPMs of baseline (left) and CASCADE (right) Condition**

All information elements mentioned in the description match to information elements in the Information Model, and were inter-linked with them in each CPM.

### Spatial Model

The Spatial Model was directly built on the basis of a 3D model which was used to instrument a CNC machine to create the bridge console (depicted on Figure 76). The model was provided as Solidworks file, which was imported into Blender, to finally transform it into an EMod 3D model. The model was merged with sensomotoric geometries of displays and mannequins and the 15° optimum sight sensomotoric geometry of the Spatial Model in evaluation 1. The



merging result is depicted on Figure 84, where solely visual sensomotoric geometries are depicted, to reduce clutter through other modalities' geometries.

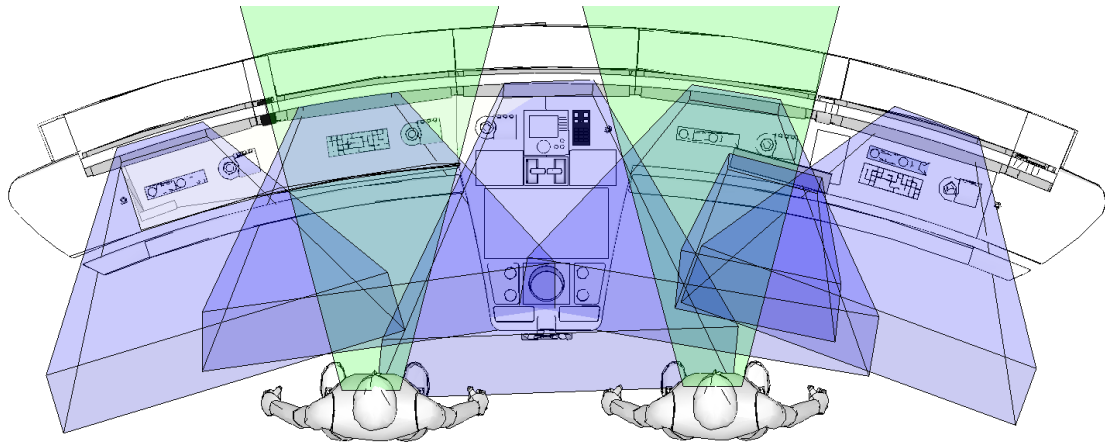

**Figure 84: 3D model with sensomotoric vision geometries of the simulator and PPU (right)**

In the evaluation of both conditions, the multifunctionality of the systems plays a relevant role, since they make a difference in the gathered CPMs. A layout model was automatically created out of the depicted 3D model with the LayoutEditor. The model is depicted on Figure 85.

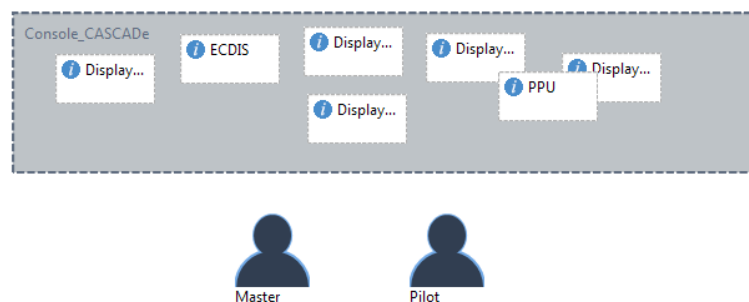

**Figure 85: LayoutEditor model created from 3D model on Figure 84**

In contrast to evaluation of hypothesis 1, the ECDIS and PPU consists of a state machine with multiple states (*IStates*), which describes the multifunctionality. Transitions define the possibility to change the actual state and thus corresponding information supply and demand during runtime (compare e.g. *InformationState* on Figure 45 and chapter 5.1.5 on StatechartEditor). A transition's direction is always defined from a source state to a target state. Analogue to the simulator the state charts of ECDIS and PPU implement the features of the baseline and CASCADE condition. For each screen on the simulator, which was used in the two conditions, a state has been defined. ECDIS' and PPU's state charts are depicted on Figure 86. Each state's information supply and demand sets have been created by linking the corresponding information elements (in IMod), which were supplied and/or demanded during the cognitive walkthrough.

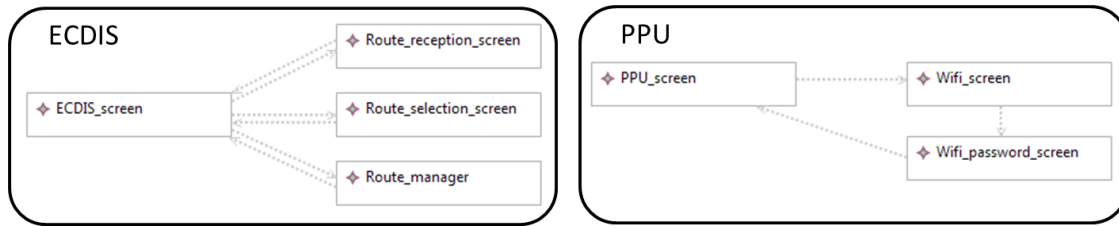

**Figure 86: ECDIS and PPU - InformationStates for baseline and CASCADE Condition**

In the baseline condition, solely the *ECDIS\_screen* and *Route\_manager* was used to add new waypoints, the *PPU\_screen* was used by the Pilot on the PPU. Both, *ECDIS\_screen* and *PPU\_screen*, were modelled with equal information elements, since there was no difference identified for the steps during the analysis.

In the CASCADE condition, the Pilot used the *Wifi\_screen*, followed by the *Wifi\_password\_screen* to initialize the route exchange. The route has been accepted by the Master through a notification on new route's arrival on the *Route\_reception\_screen* and the route's selection on a *Route\_selection\_screen*.

**Manual Planning**

To model how the cognitive walkthroughs may occur during simulation, a manual planning of SA Transactions was carried out on the layout with the LayoutEditor for both condition's CPMs (see Figure 83). For each SA Transaction the "required state" of the SA Transaction has been defined manually. Overall 17 SA Transactions have been created for the baseline condition and 13 SA Transactions have been created for the CASCADE condition. Both conditions' Resource Management is depicted on Figure 87.

After planning, work plan verification has been executed with ShiATSu's ModellingTools. The models were all tested for consistency to CPMs and their Intervals were set correctly. The

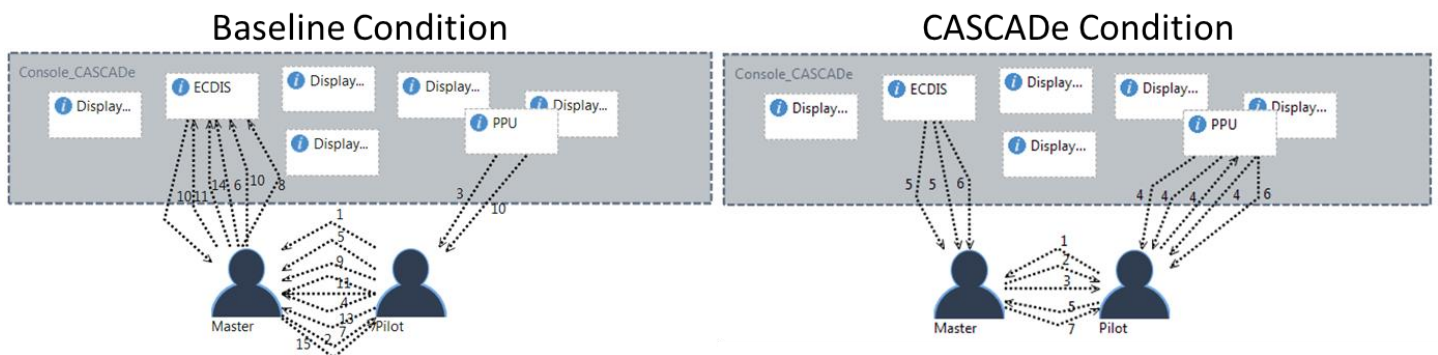

**Figure 87: Baseline Condition vs. CASCADE Condition for exchanging a route**

existence of *IStates* requires to check for conflicts between human agents demanding and supplying information on the same machine but in different states. But as perceivable from the planning, there were no conflicts between human agents possible. Overall every supply and demand of information elements defined in the CPMs was satisfiable with the described setup. The models were valid.

### **6.3.2.2 Simulation**

The LayoutEditor model, created during modelling, has directly been taken for simulation. Again, human agents' bodies were 1.80m in height and had a maximum diameter of 70cm. Besides the human agent-induced changes, there were no further environment dynamics considered. To verify the imported 3D model, runtime verification has been performed. Its resulting occupancy grid is depicted on Figure 88. Hence there were no dynamics, the work environment' Spatial Model remains static.



**Figure 88: Excerpt of the occupancy grid generated during runtime verification**

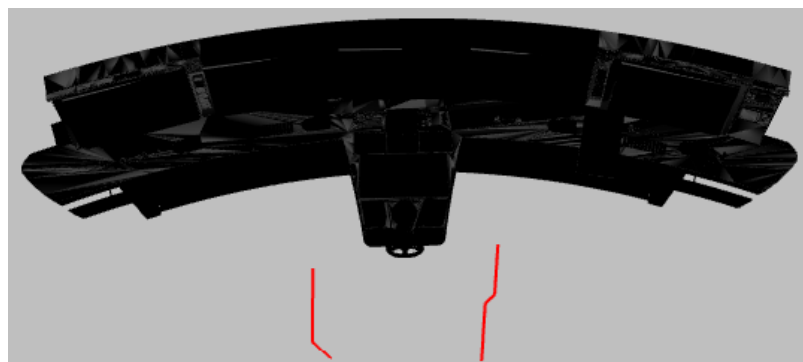

**Figure 89: Screenshot from 3DViewer visualizing the ship bridge with human agents' paths (baseline condition)**

Finally, ShiATSu was used to execute the work of the human agents defined in the Integrated Model via the SA Transactions. After simulation, the paths of human agents were visualized with the 3DViewer. All paths were reflecting the IM's SA Transactions. There were exactly two paths in both conditions, since the CPMs were only linking to one machine agent for each

human agent (defined by the SA Transactions). Figure 89 shows a screenshot of the baseline condition's resulting paths, which were visualized with the 3DViewer.

### 6.3.2.3 Analysis

In the course of simulating, the Computational Analytics step has been executed for every simulation run automatically by ShiATSu. This resulted into LMCs, which did not yield and interferences, and a low level and a high level report with costs for Resource Management Execution.

#### Life and Motion Configuration

There were no interferences found. The LMCs can especially be helpful to reason about the detailed Resource Management Execution. E.g. it's possible to reason about Information State changes.

```
5. ...
6. Pilot <- PPU
7. { (selected_wifi-Demand) & (selected_wifi-Supply),
8.     Ex.selected_wifi-Demand & (selected_wifi-Supply),
9.     e[selected_wifi] }
10. ...
```

**Figure 90: LMC with change of an Information State**

As shown in the listing on Figure 90, the Pilot is looking for the information elements *selected\_wifi* and *available\_wifis*. Initially the Pilot will walk to the PPU, since *selected\_wifi* is not perceivable ((*selected\_wifi-Demand*) & (*selected\_wifi-Supply*)), next the Pilot has achieved transactability, but the PPU is not in the 'correct' Information State (*Ex.selected\_wifi-Demand* & (*selected\_wifi-Supply*)), and after switching to the 'correct' Information State the information supply has achieved transactability for *selected\_wifi* as well (*e[selected\_wifi]*).

#### Report Assessment

Next, the high level reports created with ShiATSu, have been compared, which are depicted on Figure 91. The values for traversal and orientation of the Master and Pilot are the same in comparison between both conditions. This is, since the Spatial Model was equal and SA Transactions were executed in the same order on the same machine agents in both conditions. Thus, obviously the outcome of this comparison is showing the determinism of ShiATSu's cost calculation functions.

Since there was no difference in the cost for traversal and orientation on the high level, low level reports have been examined. The low level report of the baseline condition is shown on

*Hypothesis 3: Collaborative Process has an Effect on SA*

Figure 92. It is shown that cost shown on the high level has been generated during the tasks *select\_wifi* and *acknowledge\_route\_reception*.

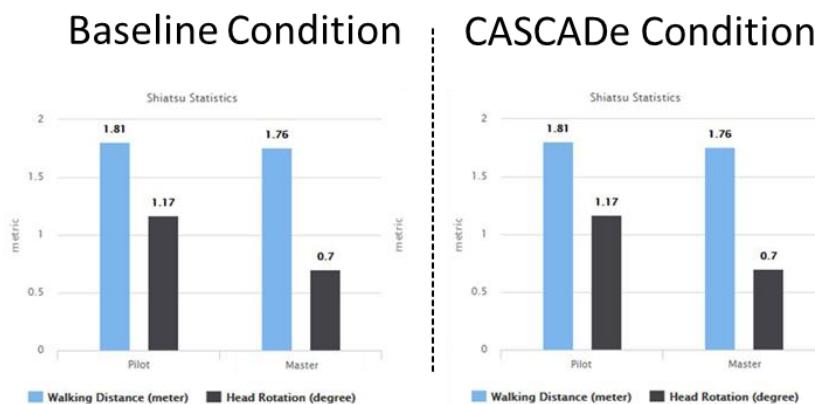

**Figure 91: High level comparison baseline and CASCADE Condition**

But cautious interpretation is required, since the baseline requires 2 SA Transactions to add 1 waypoint, while the novel route exchange feature in the CASCADE condition requires a fixed amount of 13 SA Transactions. This means, that the “breakeven point” in-between the State of the Art system and the novel route exchange system is at 3 waypoints. In terms of SA Transactions, the baseline seems favorable for routes with less than 3 waypoints and the CASCADE condition seems favorable for routes with more than 3 waypoints. The cost for SA Transaction and the matching situation are not directly shown on the high level of the current implementation of ShiATSu (compare Figure 39).

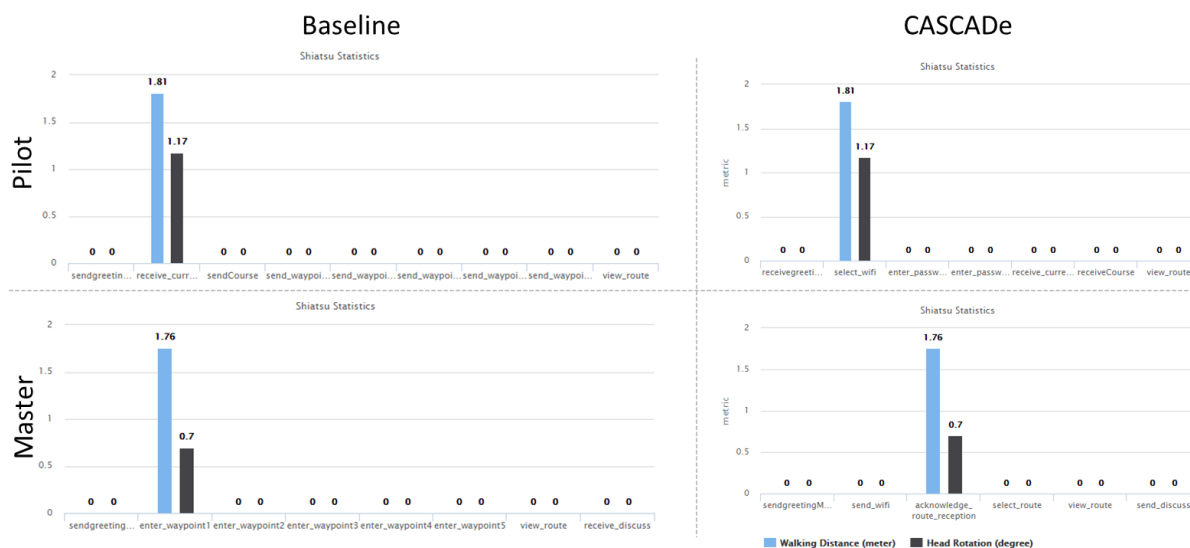

**Figure 92: Low level reports: CASCADE Condition requires less SA Transactions**

But, these costs can be deduced from the corresponding low level reports of both conditions: Here, it’s perceivable that 17 SA Transactions were modelled to execute the baseline condition

and solely 13 SA Transactions were modelled to execute the CASCADE condition. Further, the matching situation can be examined for each SA Transaction over Tversky’s ratio model similarity (RMS) as a measure of Information Supply and Demand Fitness (Denker et al. 2014). Figure 93 depicts the low level report of the Master in the CASCADE condition with figures for IG<sup>+</sup>, IG<sup>-</sup> and RMS toggled on. There exists no IG<sup>-</sup>, two times an IG<sup>+</sup> exists with each one information element, and the RMS allows inferring that *select\_route*’s Information Demand Set has one information element and *view\_route*’s Information Demand Set has three information elements. Similarly, other human agents’ of both conditions did not yield information elements in IG<sup>-</sup>. It’s noteworthy that LMC may deliver a move precise statement on the distribution of information elements into IG<sup>+</sup>, IG<sup>-</sup> and MS.

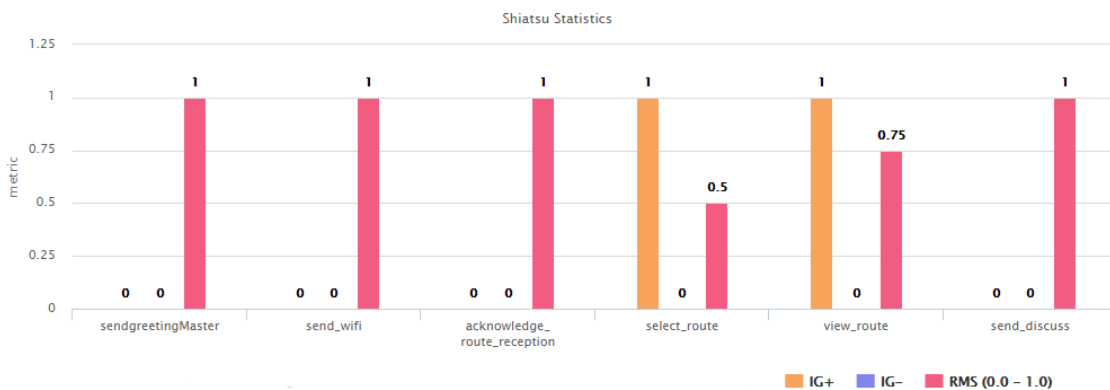

Figure 93: Low level report with IG<sup>+</sup>, IG<sup>-</sup> and RMS (Denker et al. 2014)

### 6.3.3 Questionnaire Feedback

The whole walkthrough was aligned to give qualitative feedback about the newly developed features in CASCADE. Nine experienced seafarers have been invited to the walkthroughs and the corresponding questionnaire. To derive statistical conclusions a large number of participants would have been required. This was not possible to achieve due to cost and limited amount of accessible seafarers.

#### Comparative Feedback in Steps

Questionnaire responses expressed participants’ noticeable favor for the new route exchange feature. Amongst the participants, the route exchange feature was rated with an average of 2.9 (step 3) on the 11-point scale (-5 to +5), as depicted on Figure 94. Thus, the route exchange feature was tending to be “better as conventional tools”. As depicted, other features such as checklists and virtual pilot card were rated to be neutral to positive.

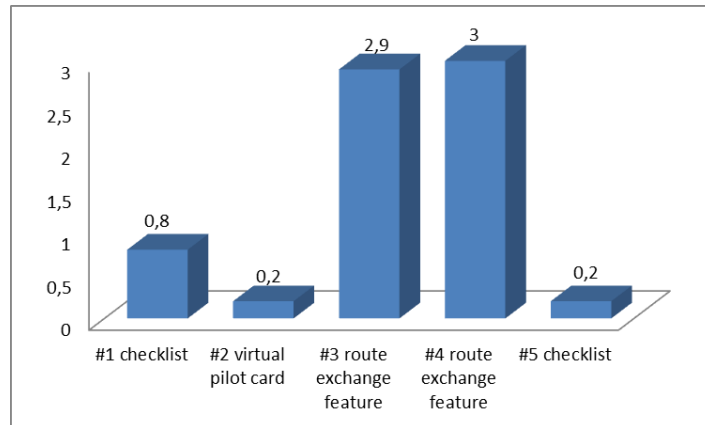

**Figure 94: Mean values for comparative feedback of steps 1 to 5**

For step 3, four participants responded with a 4, further four participants responded 3 and one participant responded -2. Responses for step 4 are neglectable, since solely one participant responded to the item, whereas others agreed during the walkthrough, that they will leave the response out, since it is equal to the response of step 3. Thus caution (!) on Figure 94 step #4, it solely shows one response.

### **Comparative Feedback on Route Exchange**

Further, the questionnaire asked to rate the new PPU tools on the same 11-point scale from -5 to +5, with the results shown in the upper left part of Figure 95. As the figure shows, mean scores for physical effort (1.7), mental effort (1.1) and increase in safety (1.9) were all positive. The answers to all three items were ranging between 4 and -1. It needs to be mentioned, that there was only one negative answer (the -1) on *increase in safety*, six responses were neutral (0), and 21 responses were positive (ranging 1-4).

When asked “do you think the PPU design you have seen is an overall improvement over PPU designs commonly available now?” (Figure 81, Question 26), one of the Pilots responded “no”, but the other three responded “yes”. Also, one seafarer responded “no”, whereas 4 seafarers gave the response “N/A (not familiar with PPU design)”.

Comments on the PPU tools were given by overall 3 participants. A seafarer wrote that the exchange tool may help to bridge language barriers. Two Pilots were referencing the application of a similar route exchange tool that is already in production in Rotterdam harbour.

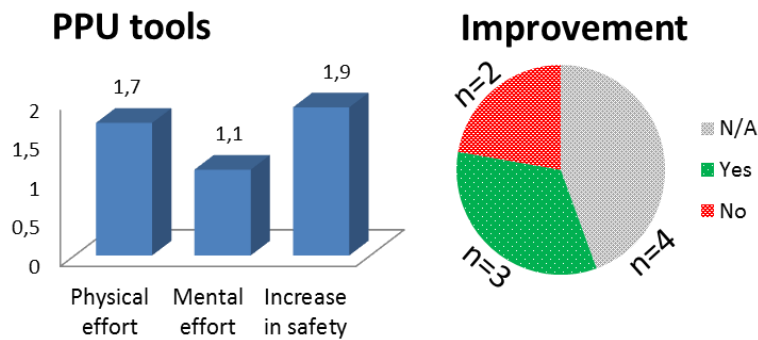

### Comments

- Very good in regions like China. You could show and don't have to talk so much. (Seafarer)
- See Rotterdam pilots. Similar equipment (Pilot)
- Advanced PPU's are already in use, why CASCADE (Pilot)

**Figure 95: Comparative feedback on route exchange**

### 6.3.4 Results

Under consideration of the output of method execution and questionnaire feedback no evidence was found, that may falsify that “Collaborative Process has an Effect on Situation Awareness”.

The method execution showed that the cost for traversing and orientation is equal in baseline and CASCADE condition, but a difference in the amount of SA Transactions required to execute both CPMs was found. The baseline’s CPM is solely favorable for exchange of routes with 3 or less waypoints. From the DSA point of view, both Master and Pilot agent reduce SA Transactions during the exchange of routes with more than 3 waypoints by using means of the CASCADE condition. The questionnaire showed that the route exchange feature was favored over current State of the Art means. Participants responded that the new feature “will make things better” in terms of physical effort, mental effort and safety. Three out of four Pilots, who are using PPU's in daily work, attested an improvement through the novel route exchange feature.

As defined with the algorithm for general Resource Management Execution, SA Transactions require human agents to spend efforts on traversal, postural change, but also on the pure transaction. Within the ShiATSu results these transaction cost, which may also require minor body movements, e.g. clicking a mouse, are quantified as cost of 1 unit per SA Transaction. In the use case of the route exchange feature, 1 unit encapsulates the touch interaction on the PPU (for the Pilot) and keyboard and mouse interaction on the ECDIS (for the Master).



On the described systemic level of this thesis' approach there was found no proof that would falsify the hypothesis, that Collaborative Process has an effect on Situation Awareness. Again, due to the number of participants no causation could have been proven, but the hypothesis' claim for existence of a correlation was successfully demonstrated.

## **6.4 Conclusion & Objectives' Coverage**

All three hypotheses could not be falsified over the course of evaluation. The evaluation materials, methods and results have been described in detail. To give a causal proof of the hypotheses' claims, bigger sample sizes are required. Interestingly, during evaluation of hypothesis 2, an effect in-between workload and Situation Awareness has been discovered, that is reported in current literature. Besides the results, which were reported in chapters 6.1, 6.2 and 6.3, this conclusion focuses on the achieved objective coverage.

Therefore, each sub-question and its objectives are considered referencing presented parts of the evaluation. Further, some parts of the software prototype have not been applied during evaluation, thus the artifact evaluation yields, which are described as well.

### **On Sub-Question 1: Which concepts/methods/techniques are needed to represent spatio-temporal information supply and demand of bridge and crew?**

During evaluation of the three hypotheses, the concepts and method have been applied with ShiATSu; these give a joint answer to the question. As foreseen in the method, ShiATSu can integrate crew work organization and bridge information distribution (fulfilling objective 1). Integrated Models have been setup during the method's execution in chapters 6.1.2 and 6.3.2. The crew work organization is defined with sequential tasks and collaborative teamwork (objective 2) in CPMs, which can be modelled with ShiATSu's Mophisto component. The component links to a *IE* set, defined with the IMod component. As shown in evaluation of hypothesis 3, dynamic information presentation (objective 3) can be modelled with the concepts of *IStates*, which is described with the method's modelling step. Tertiary systems forcing changes of the information distribution have not been demonstrated, but exist within method and artifact. Crew work organization and bridge information distribution can be adjusted (objective 4) separately from each other. With evaluation of hypothesis 1 it is described how bridge information distribution is adjusted. Hypothesis 3's evaluation showed adjustment of crew work organization. For ad-hoc coupling SA Transactions are planned within the method. Therefore, two approaches exist: manual planning and automated planning with

heuristics. In evaluations the manual planning approach was described, fulfilling the objective and to precisely model the interactions captured during non-virtual simulations. The automated planning is a feature, which has not been applied in these evaluations, but has been described with its implementation (chapter 5.1.6). Reusability of crew work organization and bridge information distribution (objective 5) has been demonstrated within both method executions. CPMs are reusable, as well as Spatial Models, Layout Models and Information Models. During evaluation of hypothesis 3, the Information Model of hypothesis 1 was reused. Within both evaluations either CPMs or Spatial Models were adjusted on the Layout Models. The formalization of bridge information distribution and crew work organization, including concepts, method and metrics (objective 6) led to precise semantics of assertions of qualitative LMCs and also to a separation in-between the quantitative measures for cost of traversal, postural change and transaction.

### **On Sub-Question 2: Which methods and metrics enable measurement of the Information Gap between information supply and demand for spatio-temporal dimensions?**

As an answer to the question, this thesis proposes both qualitative and quantitative measures for the “measurement of misfits between information supply and demand” (objective 7). Qualitatively LMCs allow on the basis of the set theory and sensomotoric geometries to make assertions about the information supply and demand fitness. During the evaluations insights of the usage of the calculus are given. Besides LMCs, ShiATSu’s results contain low level and high level reports with quantitative measures. These consider traversal, postural change and transaction. ShiATSu’s algorithms for quantitative measures are deterministic. ShiATSu allows for traceability of misfits (objective 8). The Layout Model loosely couples the CPMs, Spatial Model, and Information Model over SA Transactions. From Analysis’ outputs, misfits and interferences can be traced back to agents and artifacts, their time and position, relating tasks and information states. As demonstrated, therefore LMCs can be used formally and ShiATSu’s 3D Viewer can be used to gain visual insights. Comparability of measurements (objective 9) is given by resulting reports. Thereby, a target of evaluation needs to be set, which is either the CPMs or the Spatial Model. Within evaluation of hypothesis 1 the target of evaluation is the Spatial Model, whereas in hypothesis 2 the target of evaluation is the CPMs.

The objectives have been achieved. An integrated answer on both sub-questions has been developed.

## **7 Summary and Outlook**

In conclusion, the work described with this thesis is summarized in chapter 7.1 and an outlook is given on potential for future work and research in chapter 7.2.

### **7.1 Summary**

This thesis provides a systems-oriented assessment method for spatio-temporal information supply and demand fitness of human-machine systems, which is integrable into nowadays ship bridge design. Non-fitting information, meaning too much or too less information, may negatively influence crew's Situation Awareness, which is a most prominent cause of human factor faults in shipping casualties. To eliminate this cause, fitness can be achieved through adjustments of the crew work organization and/or bridge information distribution. But, during nowadays planning, design and construction of a ship bridge the (adjustments of) crew work organization, which occur during ship's operation, are neglected. On the other side, adjustments of the bridge information distribution are not easily applicable during operation, and lead to a fixed information distribution on the bridge, which may not fit to operational requirements. To allow manufacturers to consider the adjustment classes during planning and design, this thesis gives an answer to the question "How to assess ship bridges for crew's information supply and demand in navigational situations during design time?" and derived objectives.

To cover the objectives, related work is presented in chapter 2. The general human-centered design process for integration of ergonomics into human-machine systems is introduced. That process provides a framework of four activities, whereas the proposed method can be integrated into evaluation of a design as inspection-based evaluation (activity 4). In naval architecture engineering nowadays standards, guidelines and regulation drive the development of a ship bridge. Criteria for bridge information distribution and the human factor of the IMO and the classification society DNVGL are presented, which are considered in this thesis. Since Situation Awareness is undefined within these criteria, the theories of individualistic Situation Awareness and Distributed Situation Awareness are described. The theory of Distributed Situation Awareness gives this thesis its systemic foundation of agents and artifacts, which are transacting information elements via SA Transactions. The State of the Art provides two methods for analyzing Distributed Situation Awareness: EAST and WESTT. Both methods lag identification of non-fitness in-between information supply and demand,

spatio-temporal aspects, and hardly couple SA Transactions, such that incurred networks', agents', artifacts' and processes' reusability is difficult.

Through comparison of related work to the defined objectives, requirements are defined in chapter 3. Therefore, three requirement groups are created, that contain requirements on the representation of spatio-temporal information supply and demand of bridge and crew, execution of crew work on the bridge, as well as provisioning of measurements. Overall, these requirements strive to encounter shortcomings in the related work to fully cover the objectives.

A method and concepts have been developed, which are described in chapter 4, to fulfill the requirements. The method builds upon three concepts, which take the Distributed Situation Awareness theory into account and extend its concept of SA Transactions to enable a formal spatio-temporal assessment. This includes a separation into information supply and information demand and the consideration of spatio-temporal aspects for simulation and assessment of human-machine systems. The method allows assessing both bridge information distribution and crew work organization jointly and to examine adjustments in crew work organization and bridge information distribution. The separation of information supply and demand is described as set theory, which is derived from literature in Situation Awareness and business studies. The set theory formally defines information, information supply and information demand, their matching situation, information gap plus ( $IG^+$ ) and minus ( $IG^-$ ) as sets, and a mapping function for SA Transactions. The set theoretical approach of information supply and demand is extended for spatiality with the concept of sensomotoric geometries. These are geometries representing a modalities transactability of information supply and demand in space. A 9IM predicate for transactability of information supply and demand sets is derived, considering agents'/artifacts' body geometries and sensomotoric geometries. The third concept is a generalized spatio-temporal reasoning model for information supply and demand, which adopts from the LMC calculus. Spatio-temporal states express the *existence* and *transactability* of information elements of supply and demand separately, allowing formalizing into and reasoning about relations of information supply and demand in space and time.

The method facilitates these concepts in its three steps of modelling, simulation and analysis. During modelling an Integrated Model Triangle is setup consisting of an Information Model, a Spatial Model and a Collaborative Process Model. SA Transactions are planned and verified either manually or with an automated approach, constituting the Resource Management.

During simulation the Integrated Model is extended to a 3D simulation environment, which incorporates scheduling of dynamic events to simulate tertiary systems (e.g. sensor system changing the information distribution at a specific point in time). At simulation runtime, static and/or dynamic parts of the environment may violate ergonomic design requirements, thus the IM is verified for violations with test specimen. The Resource Management is then executed on the runtime-verified Integrated Model, yielding efforts for traversal, postural change and transaction. During analysis LMC are elicited and used to detect interferences, which may have occurred during runtime. Further, reports are created, that yield insights on efforts of simulation execution. Finally, the method foresees its user to interpret one output or to compare multiple outputs, with his/her scope of the assessment.

The method is computer-supported by the software prototype ShiATSu, which is described in chapter 5. ShiATSu consists of eight components, which are used to model, simulate and analyze the Integrated Model. Its software architecture is described considering data structures, and its software implementation is described with excerpts from applications.

ShiATSu was applied to perform research on three hypotheses, which is described in chapter 6. The hypotheses are that 1) differences between Work Spaces are representable and measurable, 2) Work Space Layout has an Effect on Situation Awareness, and 3) Collaborative Process has an Effect on Situation Awareness. The evaluation through hypothesis testing shows the application of the method and demonstrates the coverage of the objectives. To test hypothesis 1 a simulator study with two conditions has been executed. The conditions had alternative bridge information distributions, since condition two tested novel equipment - a "Shared Display", which was designed with professional human factors engineers in the European CASCADE project. The method has been executed for both conditions, containing each one Information Model, one Spatial Model of the simulator suite and 13 Collaborative Processes elicited from four exhaustive simulation runs sailing out of Kiel harbour. The result is that differences between Work Spaces are representable and measurable with the method and ShiATSu. For testing hypothesis 2, a questionnaire has been executed asking seafarers, which were participating in the simulator study, on their subjective simulation performance and on their comparative feedback between the both conditions. Additionally, the simulator instructor was asked for his observatory expert judgement. The six seafarers' and the instructor's feedback was compared to the measurements of hypothesis 1. It's shown that a correlation between Work Space Layout and Situation Awareness exists. Due to the small sample size causal relations cannot be identified. But, interestingly the results reflect findings in literature. For testing hypothesis 3, a cognitive walkthrough has been executed for sharing

of a route between Pilot and Master. In the first condition State of the Art features and in the second condition a novel route exchange feature was evaluated. Nine active seafarers were discussing the collaborative processes. The thesis' method was executed with ShiATSu and outputs were compared for both conditions. A questionnaire was executed, which was asking the participants for feedback on the features and their subjective Situation Awareness measures. No evidence was found with the small sample size that falsifies "Collaborative Process has an Effect on Situation Awareness". However, a correlation was found.

The evaluation confirms that the presented method, concepts and ShiATSu cover the objectives of this thesis.

## **7.2 Outlook**

It was shown that the method and ShiATSu meet the objectives and requirements of this thesis. However, there may be chances to extend the contribution through consideration of the following aspects.

- Larger sample sizes – The hypotheses tests of the evaluations base on relatively small sample sizes, which did not permit to prove causal relations due to statistical power. A challenge is to build a representative group of participants under the constraints of the device factors, which may influence experiments. Answers may be found in the field of statistics. E.g. for sample size calculations in clinical trials Röhrig et al. give an insight (Röhrig et al. 2010). In future, research with larger sample sizes could yield quantitative proven causal relations between Collaborative Processes, Work Space Layout and Situation Awareness.
- Automated Model Optimization – Representation and measurement of spatio-temporal information supply and demand has been achieved with this thesis. Qualitative and quantitative measures were defined, which are used to assess the Integrated Model's execution. Future work may examine how to optimize a Spatial Model for a specific set of Collaborative Process Models or vice versa. This would require a definition of feasible Spatial Models and algorithms to adjust crew work organization and/or bridge information distribution (Fischer 2012; Michalek & Papalambros 2002).
- Individualistic Approaches of SA – The systemic approach fostered in this thesis' method may profit from potentials through integration of individualistic Situation

Awareness approaches. For example the Three Level Model's level could be attributed to information elements and information elements could then be deducible from higher levels and vice versa (Jones et al. 2010). Another example could be integration of agent's observations and upon built beliefs about Situation Awareness also under consideration of temporal aspects (Bosse et al. 2012; Baumann & Krems 2009).

- Further Human Factors – Besides Situation Awareness, other human factors could be researched systemically. Accident report reviews e.g. state workload as a smaller, but non-neglectable influence factor to human error at sea (Hetherington et al. 2006). How could workload be integrated into a spatio-temporal information supply and demand assessment? Certainly, there exist individualistic approaches to predict workload (Aldrich et al. 1989). But, how could such an approach be transferred to a "distributed workload" approach? Further, questions to research other factors could be asked: How resilient is the current Resource Management? How prone is the system to fatigue?
- Application in other Domains – This thesis focuses on an application in the maritime domain. However, the approach might be applicable in other domains as well. An interesting outlook of this thesis could be to research, whether this thesis solution is applicable to classes of control rooms. For instance air traffic control, nuclear power plant control and distributed medical systems could be further areas of application, in which this thesis' may have a chance to contribute its method and concepts for assessment and whose outcomes may lead to improved safety for human life and the environment.





## 8 References

- van der Aalst, W.M.P., Song, M. & Aalst, W. Van Der, 2004. Mining Social Networks: Uncovering interaction patterns in business processes. *Business Process Management - Lecture Notes in Computer Science*, 3080, pp.244–260. Available at: [http://link.springer.com/chapter/10.1007/978-3-540-25970-1\\_16](http://link.springer.com/chapter/10.1007/978-3-540-25970-1_16).
- Adams, M.J., Tenney, Y.J. & Pew, R.W., 1995. Situation awareness and the cognitive management of complex systems. *Human Factors: The Journal of the Human Factors and Ergonomics Society*, 37(1), pp.85–104.
- Aldrich, T.B., Szabo, S.M. & Bierbaum, C.R., 1989. *The development and application of models to predict operator workload during system design*, Springer.
- Allen, J.F., 1983. Maintaining knowledge about temporal intervals. *Communications of the ACM*, 26(11), pp.832–843.
- Annett, J., 2003. Hierarchical task analysis. *Handbook of cognitive task design*, pp.17–35.
- Antão, P. & Guedes Soares, C., 2006. Fault-tree models of accident scenarios of RoPax vessels. *International Journal of Automation and Computing*, 3(2), pp.107–116.
- Baber, C. et al., 2008. *Application of WESTT to System Redesign*,
- Baber, C. et al., 2013. Using social network analysis and agent-based modelling to explore information flow using common operational pictures for maritime search and rescue operations. *Ergonomics*, 56(6), pp.889–905. Available at: <http://www.ncbi.nlm.nih.gov/pubmed/23607874>.
- Baker, C.C. & McCafferty, D.B., 2005. Accident database review of human element concerns: What do the results mean for classification? *Human factors in ship design, safety and operation, February 23-24, London, Royal Institution of Naval Architects*.
- Balzert, S. et al., 2011. Operationalisierbarkeit von Methoden zur Prozesserhebung. In *Vorgehensmodelle im Geschäftsprozessmanagement*.
- Baumann, M. & Krems, J., 2009. A comprehension based cognitive model of situation awareness V. G. Duffy, ed. *Digital Human Modeling*, 5620, pp.192–201. Available at: [http://apps.isiknowledge.com/full\\_record.do?product=WOS&search\\_mode=GeneralSearch&qid=18&SID=4BDeGBdjGLPBcO1BL9@&page=6&doc=52](http://apps.isiknowledge.com/full_record.do?product=WOS&search_mode=GeneralSearch&qid=18&SID=4BDeGBdjGLPBcO1BL9@&page=6&doc=52) [Accessed September 30, 2013].
- Bevan, N., 2009. Criteria for selecting methods in user-centered design. *Proceeding of I-USED'09 Workshop, INTERACT 2009*, 10(2003), pp.28–34. Available at: [http://www.nigelbevan.com/papers/Criteria\\_for\\_selecting\\_methods\\_in\\_user\\_centred\\_design.pdf](http://www.nigelbevan.com/papers/Criteria_for_selecting_methods_in_user_centred_design.pdf).
- Blauert, J., 1997. *Spatial hearing: the psychophysics of human sound localization*, MIT press.

## References

---

- Bolstad, C., Costello, A. & Endsley, M., 2006. Bad situation awareness designs: What went wrong and why. *Proceedings of the 16th ...*. Available at: [http://209.238.175.8/Papers/pdf/Bolstad Costello Endsley \(2006\) IEA.pdf](http://209.238.175.8/Papers/pdf/Bolstad%20Costello%20Endsley%20(2006)%20IEA.pdf) [Accessed October 30, 2013].
- Bolstad, C.A. et al., 2002. USING GOAL DIRECTED TASK ANALYSIS WITH ARMY BRIGADE OFFICER TEAMS.
- Borrmann, A., Treeck, C. Van & Rank, E., 2006. Towards a 3D spatial query language for building information models. In *Joint Int. Conf. of Computing and Decision Making in Civil and Building Engineering (ICCCBE-XI)*.
- Bosse, T., Merk, R.J. & Treur, J., 2012. Modelling temporal aspects of situation awareness. *Lecture Notes in Computer Science (including subseries Lecture Notes in Artificial Intelligence and Lecture Notes in Bioinformatics)*, 7663 LNCS, pp.473–483.
- Burke, C.S., 2004. Team Task Analysis. In N. A. Stanton et al., eds. *Handbook of Human Factors and Ergonomics Methods*. Boca Raton: CRC Press, pp. 561–568.
- Chauvin, C. et al., 2013. Human and organisational factors in maritime accidents: Analysis of collisions at sea using the HFACS. *Accident; analysis and prevention*, 59, pp.26–37. Available at: <http://www.ncbi.nlm.nih.gov/pubmed/23764875> [Accessed November 15, 2013].
- Denker, C. et al., 2014. Assessing the Fitness of Information Supply and Demand during User Interface Design. *Proceedings of the 5th International Conference on Applied Human Factors and Ergonomics AHFE 2014*, 3(July), pp.521–530.
- Denker, C. et al., 2015. Nutzung der virtuellen Realität zur Erhebung von nautischen Prozessen. In U. F. von Lukas, E.-M. Mahnke, & K. Bauer, eds. *Go-3D 2015 "Computergraphik für die Praxis."* Fraunhofer Verlag, p. 203.
- DNVGL, 2014. *Rules for Classification of Ships - Part 6 Chapter 20 - NEWBUILDINGS SPECIAL EQUIPMENT AND SYSTEMS – ADDITIONAL CLASS - Nautical Safety – Offshore Service Vessels*,
- Driskell, J.E. & Mullen, B., 2004. Social Network Analysis. In N. A. Stanton et al., eds. *Handbook of Human Factors and Ergonomics Methods*. UK, pp. 581–586.
- Egenhofer, M., 1989. A formal definition of binary topological relationships. *Foundations of Data Organization and Algorithms*, 367, pp.457–472. Available at: [http://dx.doi.org/10.1007/3-540-51295-0\\_148](http://dx.doi.org/10.1007/3-540-51295-0_148).
- Egenhofer, M. & Herring, J., 1990. Categorizing binary topological relations between regions, lines, and points in geographic databases. *The*, 9, pp.94–1. Available at: [http://didattica.univaq.it/moodle/file.php/1508/9intReport\\_Egenhofer\\_1992.pdf](http://didattica.univaq.it/moodle/file.php/1508/9intReport_Egenhofer_1992.pdf).
- Egenhofer, M.J. & Franzosa, R.D., 1991. Point-set topological spatial relations. *International journal of geographical information systems*, 5(2), pp.161–174.

- Egenhofer, M.J. & Mark, D.M., 1995. Modeling Conceptual Neighborhoods of Topological Line-Region Relations. *International Journal of Geographical Information Systems*, 9(5), pp.555–565.
- Elfes, A., 1989. Using Occupancy Grids for Mobile Robot Perception and Navigation. *Computer*, 22(6), pp.46–57.
- EMSA, 2014. ANNUAL OVERVIEW OF MARINE CASUALTIES AND INCIDENTS 2014.
- Endsley, M., 2000. Theoretical underpinnings of situation awareness: A critical review. In M. R. Endsley & D. J. Garland, eds. *Situation awareness analysis and measurement*. Lawrence Erlbaum Associates Inc, pp. 3–32.
- Endsley, M.R., 2015. Situation awareness: operationally necessary and scientifically grounded. *Cognition, Technology & Work*, 17(2), pp.163–167. Available at: <http://dx.doi.org/10.1007/s10111-015-0323-5>.
- Endsley, M.R., 1995a. Toward a Theory of Situation Awareness in Dynamic Systems. *Human Factors: The Journal of the Human Factors and Ergonomics Society*, 37(1), pp.32–64.
- Endsley, M.R., 1995b. Toward a Theory of Situation Awareness in Dynamic Systems. , 37(1), pp.32–64.
- Endsley, M.R. & Jones, D.G., 2011. *Designing for Situation Awareness: An Approach to User-Centered Design* 2nd ed., CRC Press.
- Endsley, M.R. & Jones, W.M., 2001. A model of inter- and intra-team situation awareness: implications for design, training, and measurement. In M. McNeese, E. Salas, & M. R. Endsley, eds. *New trends in cooperative activities: understanding system dynamics in complex environments*. Human Factors & Ergonomics Society, pp. 46–67.
- Fischer, G., 2012. Context-aware systems: the “right” information, at the “right” time, in the “right” place, in the “right” way, to the “right” person. *Proceedings of the International Working Conference ....* Available at: <http://dl.acm.org/citation.cfm?id=2254611>.
- Fricke, M., 2009. The knowledge pyramid: a critique of the DIKW hierarchy. *Journal of Information Science*, 35(2), pp.131–142.
- Germanischer Lloyd, 2012. *Rules for Classification and Construction: Ship Technology - Bridge Arrangement and Equipment on Seagoing Ships*,
- Grech, M., Horberry, T. & Smith, A., 2002. Human error in maritime operations: Analyses of accident reports using the leximancer tool. In *Proceedings of the Human Factors and Ergonomics Society Annual Meeting*. SAGE Publications, pp. 1718–1721.
- Hallot, P., 2012. L'identité à travers l'espace et le temps. Vers une définition de l'identité et des relations spatio-temporelles entre objets géographiques. , p.278. Available at: <http://hdl.handle.net/2268/113244>.
- Hallot, P. & Billen, R., 2008a. Life and Motion Configuration. *5th International Conference on Geographic Information Science, GIScience*, p.333.

## References

---

- Hallot, P. & Billen, R., 2008b. Life and motion configurations: A basis for spatio-temporal generalized reasoning model. *Lecture Notes in Computer Science (including subseries Lecture Notes in Artificial Intelligence and Lecture Notes in Bioinformatics)*, 5232 LNCS, pp.323–333.
- Hallot, P. & Billen, R., 2008c. Life and motion configurations: a basis for spatio-temporal generalized reasoning model. *Advances in Conceptual Modeling—Challenges and Opportunities*, pp.323–333. Available at: [http://link.springer.com/chapter/10.1007/978-3-540-87991-6\\_39](http://link.springer.com/chapter/10.1007/978-3-540-87991-6_39) [Accessed July 19, 2014].
- Hart, P.E., Nilsson, N.J. & Raphael, B., 1968. A Formal Basis for the Heuristic Determination of Minimum Cost Paths. *IEEE Transactions on Systems Science and Cybernetics*, 4(2), pp.100–107.
- Hetherington, C., Flin, R. & Mearns, K., 2006. Safety in shipping: The human element. *Journal of safety research*, 37(4), pp.401–411. Available at: <http://www.ncbi.nlm.nih.gov/pubmed/17046789> [Accessed July 26, 2014].
- Horberry, T. & Cooke, T., 2010. Using the Critical Decision Method for Incident Analysis in Mining. *Journal of Health & Safety Research & Practice*, 2(2), pp.11–22.
- Houghton, R.J. et al., 2008. WESTT (workload, error, situational awareness, time and teamwork): An analytical prototyping system for command and control. *Cognition, Technology and Work*, 10, pp.199–207.
- Hourizi, R. & Johnson, P., 2003. Towards an explanatory, predictive account of awareness. *Computers and Graphics*, 27(6), pp.859–872.
- Hutchins, E., 1995. *Cognition in the Wild*, MIT press.
- IMO, 2000. Guidelines on Ergonomic Criteria for Bridge Equipment and Layout.
- IMO, 2012. International Shipping Facts and Figures – Information Resources on Trade , Safety , Security , Environment. , (March).
- IMO, 1999. *NAV 45/6 Ergonomic Criteria for Bridge Equipment and Layout*,
- IMO, 2007. *Resolution MSC.252(83): Adoption of the Revised Performance Standards for Integrated Navigation Systems (INS)*,
- ISO 9241-210, 2011. Ergonomics of human-system interaction - Part 210: Human-centred design for interactive systems (ISO 9241-210:2010) English translation of DIN EN ISO 9241-210:2011-01. , p.40.
- ISO/IEC 19505-2, 2012. Unified Modeling Language (OMG UML), Superstructure. , 2012(April), p.758.
- ISO/TC 159, 1997. Principles of the Design of Work Systems.
- ISO/TR 16982, 2002. Usability methods supporting human-centred design.

- Jones, D. & Endsley, M., 1996. Sources of Situation Awareness Errors in Aviation. *Aviation, Space, and Environmental Medicine*, 67(6), pp.507–512.
- Jones, R.E.T. et al., 2010. Modeling Situation Awareness for Army Infantry Platoon Leaders Using Fuzzy Cognitive Mapping Techniques. *Processing*, (March), pp.21–24.
- Kagdi, H., Maletic, J.I. & Sutton, A., 2005. Context-free slicing of UML class models. *IEEE International Conference on Software Maintenance, ICSM, 2005*, pp.635–638.
- Kirwan, B. & Ainsworth, L.K., 1992. *A guide to task analysis: the task analysis working group*, CRC press.
- Michalek, J. & Papalambros, P., 2002. Interactive design optimization of architectural layouts. *Engineering Optimization*, 34(5), pp.485–501.
- Moravec, H. & Elfes, A., 1985. High resolution maps from wide angle sonar. *IEEE International Conference on Robotics and Automation*, 2, pp.116–121.
- Motz, F. et al., 2011. Development of requirements for communication management on board in the framework of the e-Navigation concept. ... , *e-Navigation and Safety at Sea ...*, 5(1), pp.15–22. Available at:  
[http://www.transnav.eu/Article\\_Development\\_of\\_Requirements\\_for\\_,17,262.html](http://www.transnav.eu/Article_Development_of_Requirements_for_,17,262.html)  
[Accessed November 5, 2013].
- Mouloua, M. & Gilson, R., 2001. Workload, situation awareness, and teaming issues for UAV/UCAV operations. *Proceedings of the ...*, (1997), pp.162–165. Available at:  
<http://pro.sagepub.com/content/45/2/162.short> [Accessed September 18, 2013].
- Muller, P., 2002. Topological Spatio-Temporal Reasoning and Representation. *Computational Intelligence*, 18(3), pp.420–450. Available at: <http://www.blackwell-synergy.com/doi/abs/10.1111/1467-8640.00196>.
- Neisser, U., 1976. *Cognition and reality: Principles and implications of cognitive psychology.*, WH Freeman/Times Books/Henry Holt & Co.
- Nielsen, J., 1994. Usability inspection methods. *Conference companion on Human factors in computing systems - CHI '94*, 25(1), pp.413–414. Available at:  
<http://portal.acm.org/citation.cfm?doid=157203.157207>  
<http://portal.acm.org/citation.cfm?doid=259963.260531>.
- Page, J., 2012. Flexibility in Early Stage Design of U.S. Navy Ships: An Analysis of Options. *Journal of Ship Production and Design*, 28(3), pp.128–133.
- Papanikolaou, A., 2009. *Risk-based ship design: Methods, tools and applications*, Springer Science & Business Media.
- Parasuraman, R., Sheridan, T.B. & Wickens, C.D., 2008. Situation Awareness, Mental Workload, and Trust in Automation: Viable, Empirically Supported Cognitive Engineering Constructs. *Journal of Cognitive Engineering and Decision Making*, 2(2), pp.140–160.

## References

---

- Peffer, K. et al., 2006. The design science research process: a model for producing and presenting information systems research. In *Proceedings of the 1st International Conference on Design Science in Information Systems and Technology*, pp.83–106. Available at: [http://www.wrsc.org/sites/default/files/documents/000designscresearchproc\\_desrist\\_2006.pdf](http://www.wrsc.org/sites/default/files/documents/000designscresearchproc_desrist_2006.pdf) [Accessed February 11, 2014].
- Pinkowski, J., 2015. *Prozessgetriebene Risikoanalyse zur Bewertung maritimer Operationen*. University of Oldenburg.
- Polson, P.G. et al., 1992. Cognitive walkthroughs: a method for theory based evaluation of user interfaces. , 36, pp.741–773.
- Pritchett, A.R. & Hansman, R.J., 2000. Use of testable responses for performance-based measurement of situation awareness. In M. R. Endsley & D. J. Garland, eds. *Situation awareness analysis and measurement*. CRC Press.
- Rayleigh, Lord, 1879. XXXI. investigations in optics, with special reference to the spectroscope. *The London, Edinburgh, and Dublin Philosophical Magazine and Journal of Science*, 8(49), pp.261–274.
- Röhrig, B. et al., 2010. Sample Size Calculation in Clinical Trials. *Deutsches Ärzteblatt International*, 107(31-32), pp.552–556. Available at: [http://www.ncbi.nlm.nih.gov/pmc/articles/PMC2933537/pdf/Dtsch\\_Arztebl\\_Int-107-0552.pdf](http://www.ncbi.nlm.nih.gov/pmc/articles/PMC2933537/pdf/Dtsch_Arztebl_Int-107-0552.pdf).
- Ross, J.M., 2009. *Human Factors for Naval Marine Vehicle Design and Operation*, Ashgate Publishing Company. Available at: <https://books.google.de/books?id=B2SwXoa57E4C>.
- Rowley, J., 2007. The wisdom hierarchy: representations of the DIKW hierarchy. *Journal of Information Science*, 33(2), pp.163–180.
- Salas, E., Cooke, N.J. & Rosen, M.A., 2008. On teams, teamwork, and team performance: Discoveries and developments. *Human Factors: The Journal of the Human Factors and Ergonomics Society*, 50(3), pp.540–547.
- Salmon, P. et al., 2005. *Analysing C4i Activity : A Review of the Event Analysis of Systemic Teamwork (EAST) Methodology*, Available at: [https://www.defencehumancapability.com/Portals/0/HFIDTC/HFI Methods and Models/Phase 1/1-1-3-10-east-review.pdf](https://www.defencehumancapability.com/Portals/0/HFIDTC/HFI_Methods_and_Models/Phase%201/1-1-3-10-east-review.pdf).
- Salmon, P. et al., 2009. *Distributed Situation Awareness: Theory, Measurement and Application to Teamwork*, Ashgate Publishing Ltd.
- Salmon, P.M. et al., 2008. Representing situation awareness in collaborative systems: A case study in the energy distribution domain. *Ergonomics*, 51(3), pp.367–384.
- Sarter, N.B. & Woods, D.D., 1991. Situation awareness - A critical but ill-defined phenomenon. *International Journal of Aviation Psychology*, 1(1), pp.45–57.

- Shannon, R.E., 1975. *Systems simulation: the art and science*, Prentice-Hall Englewood Cliffs, NJ.
- Smith, K. & Hancock, P., 1995. Situation awareness is adaptive, externally directed consciousness. *Human Factors: The Journal of the Human Factors and Ergonomics Society*, 37(1), pp.137–148.
- Sobiech, C. et al., 2012. Model based Development of Health, Safety, and Environment Plans and Risk Assessment for Offshore Operations. In G.Bruzzone & M. Caccia, eds. *MCMC - 9th IFAC Conference on Manoeuvring and Control of Marine Craft*.
- Sparrow, B., Liu, J. & Wegner, D.M., 2011. Google Effects on Memory: Cognitive Consequences of Having Information at Our Fingertips. *Science*, 333(6043), pp.776–778. Available at: <http://www.sciencemag.org/cgi/doi/10.1126/science.1207745>.
- Stanton, N. a., Salmon, P.M. & Walker, G.H., 2014. Let the Reader Decide: A Paradigm Shift for Situation Awareness in Sociotechnical Systems. *Journal of Cognitive Engineering and Decision Making*. Available at: <http://edm.sagepub.com/lookup/doi/10.1177/1555343414552297>.
- Stanton, N.A., 2014. Representing distributed cognition in complex systems: how a submarine returns to periscope depth. *Ergonomics*, 57(3), pp.403–418.
- Steinberg, D. et al., 2008. *EMF Eclipse Modeling Framework* 2nd ed., Boston: Pearson Education, Inc.
- Taylor, R.M., 1990. Situational Awareness Rating Technique(SART): The development of a tool for aircrew systems design. *Situational Awareness in Aerospace Operations (AGARD-CP-478)*, pp.3/1–3/17.
- Tilley, A.R. & Associates, H.D., 2002. *The Measure of Man and Woman: Human Factors in Design*, Wiley. Available at: <https://books.google.de/books?id=uMp6bNfqmsgC>.
- Tran, N.K. & Haasis, H.-D., 2015. An empirical study of fleet expansion and growth of ship size in container liner shipping. *International Journal of Production Economics*, 159, pp.241–253. Available at: <http://linkinghub.elsevier.com/retrieve/pii/S0925527314002941> [Accessed January 12, 2015].
- Tversky, A., 1977. Features of Similarity. *Psychological review*, 84(4), pp.327–352.
- Walker, G.H., Stanton, N.A. & Chowdhury, I., 2013. Situational awareness and self explaining roads. *Safety Science*, 56, pp.18–28.
- Watts, L.A. & Monk, A.F., 1998. Reasoning about tasks, activities and technology to support collaboration. *Ergonomics*, 41(11), pp.1583–1606.
- Weber, J. & Schäffer, U., 2006. *Einführung in das Controlling*, Schäffer-Poeschel.
- Wegner, D.M., 1986. Transactive memory: A contemporary analysis of the group mind. In B. Mullen & G. R. Goethals, eds. *Theories of group behaviour*. New York: Springer, p. 185.208.

## References

---

Wilson, J.R., 2014. Fundamentals of systems ergonomics/human factors. *Applied Ergonomics*, 45(1), pp.5–13. Available at: <http://dx.doi.org/10.1016/j.apergo.2013.03.021>.



## A Appendix

### A.1 Hypotheses 1 and 2 - CPMs

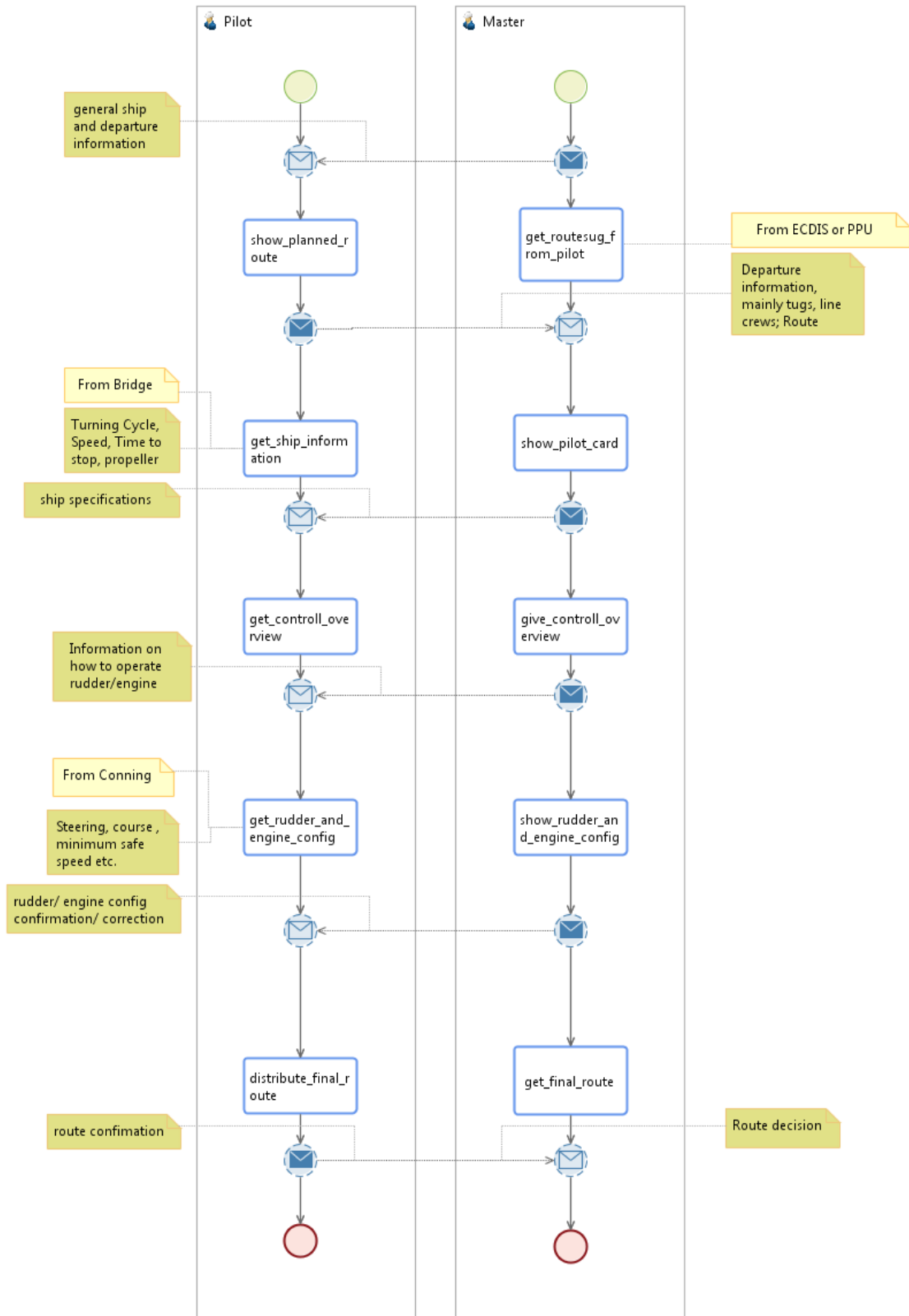

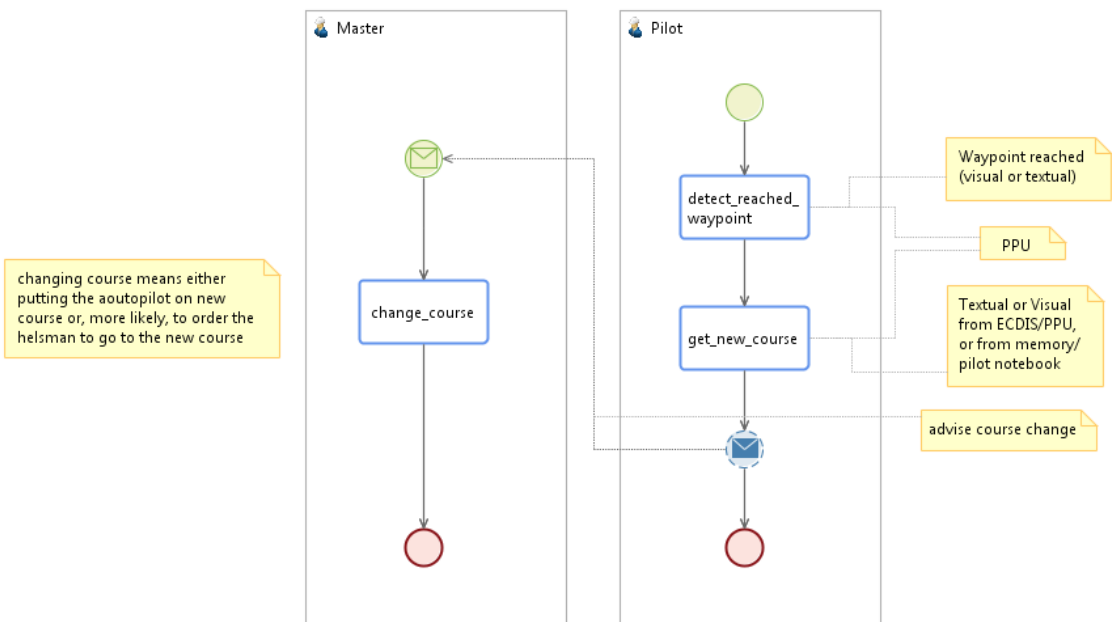
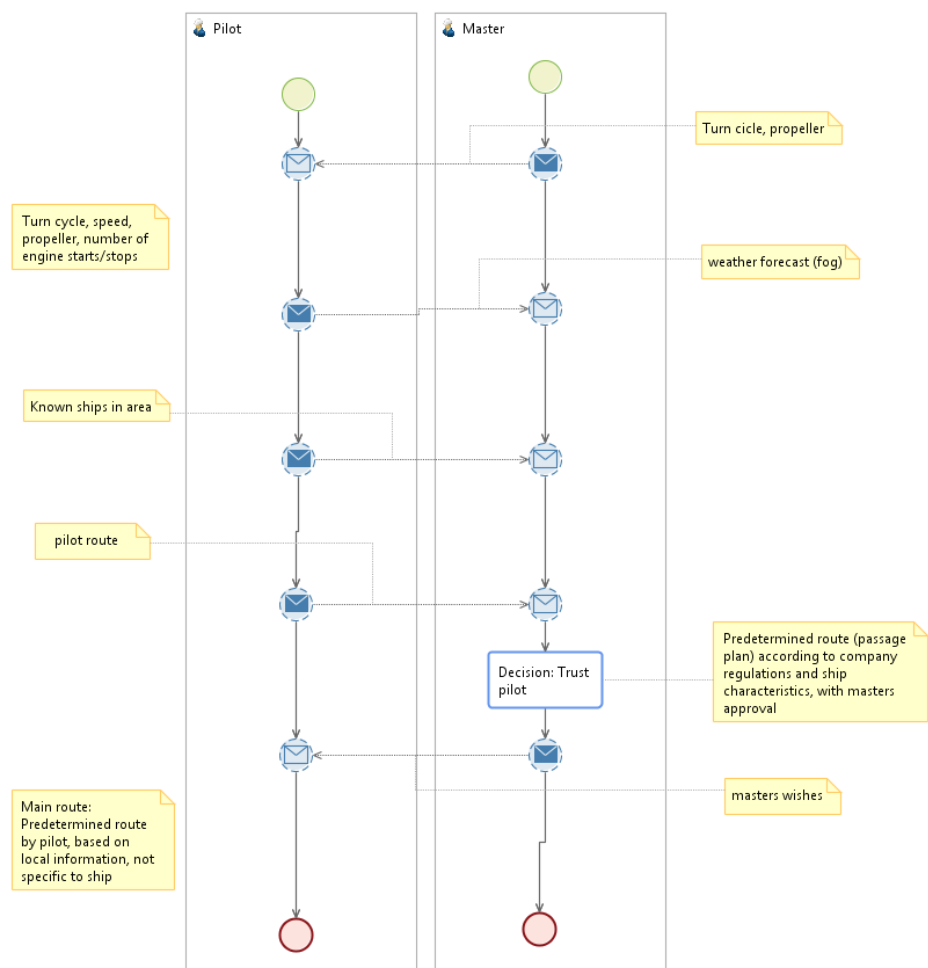

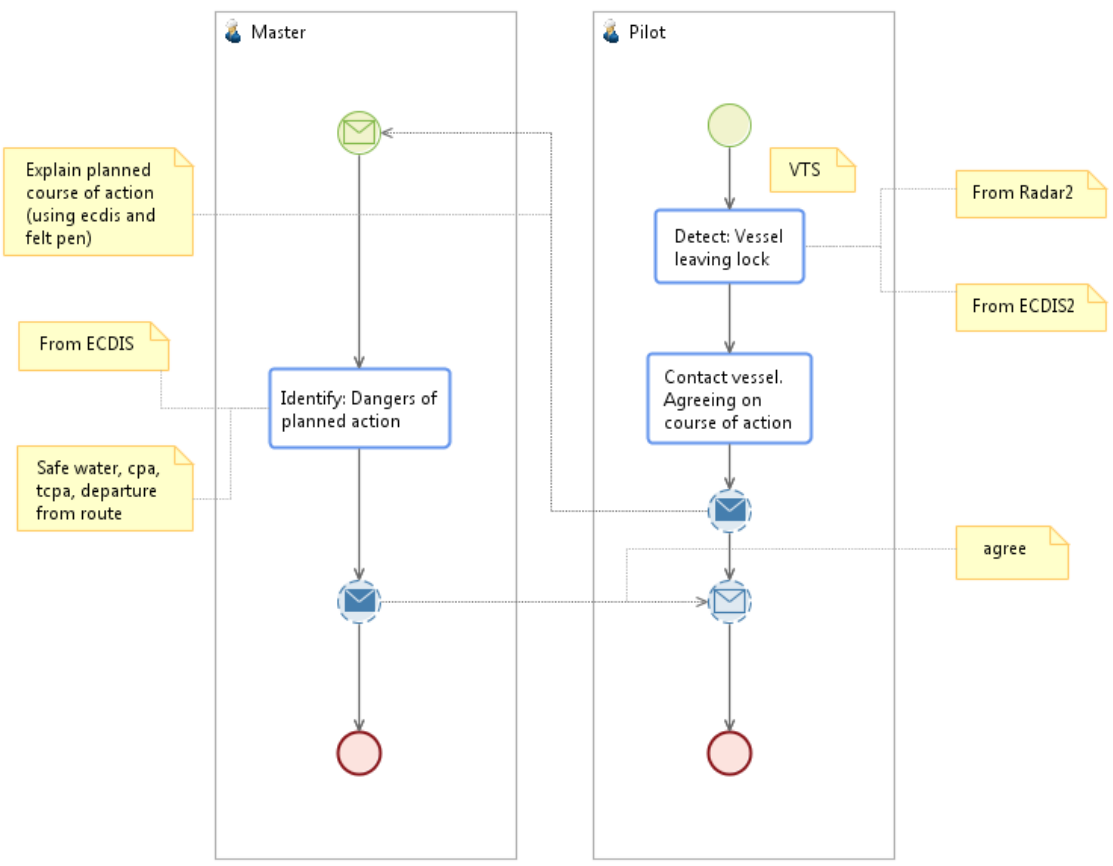
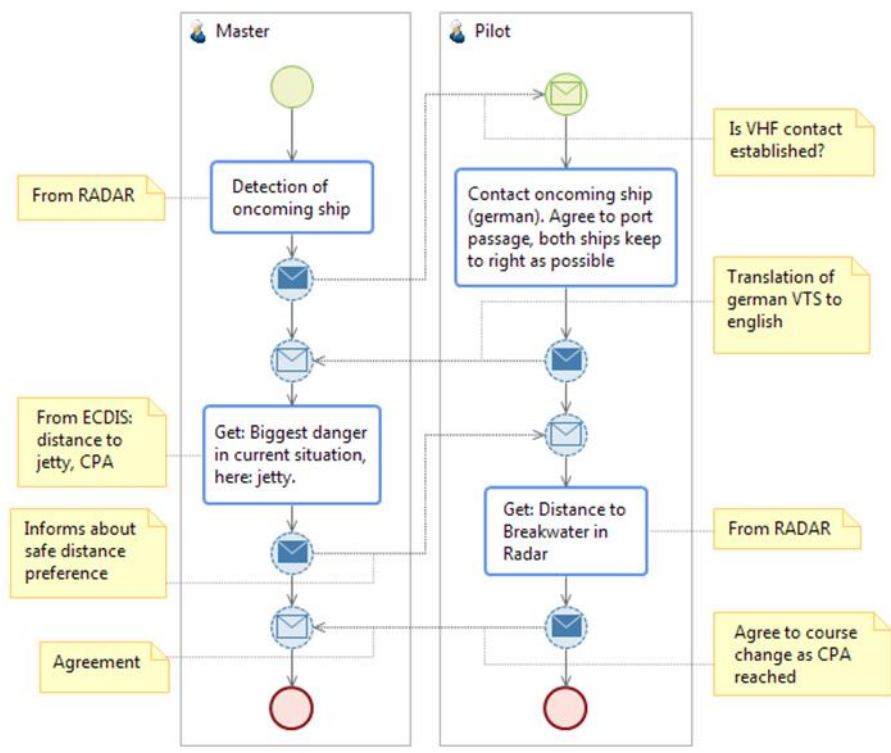

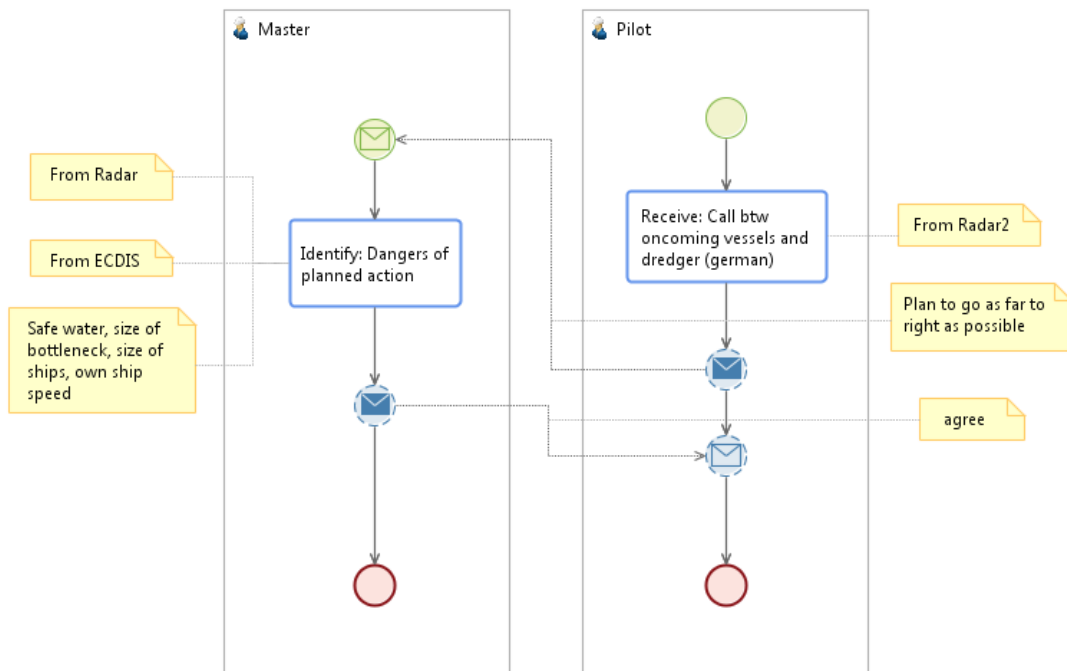
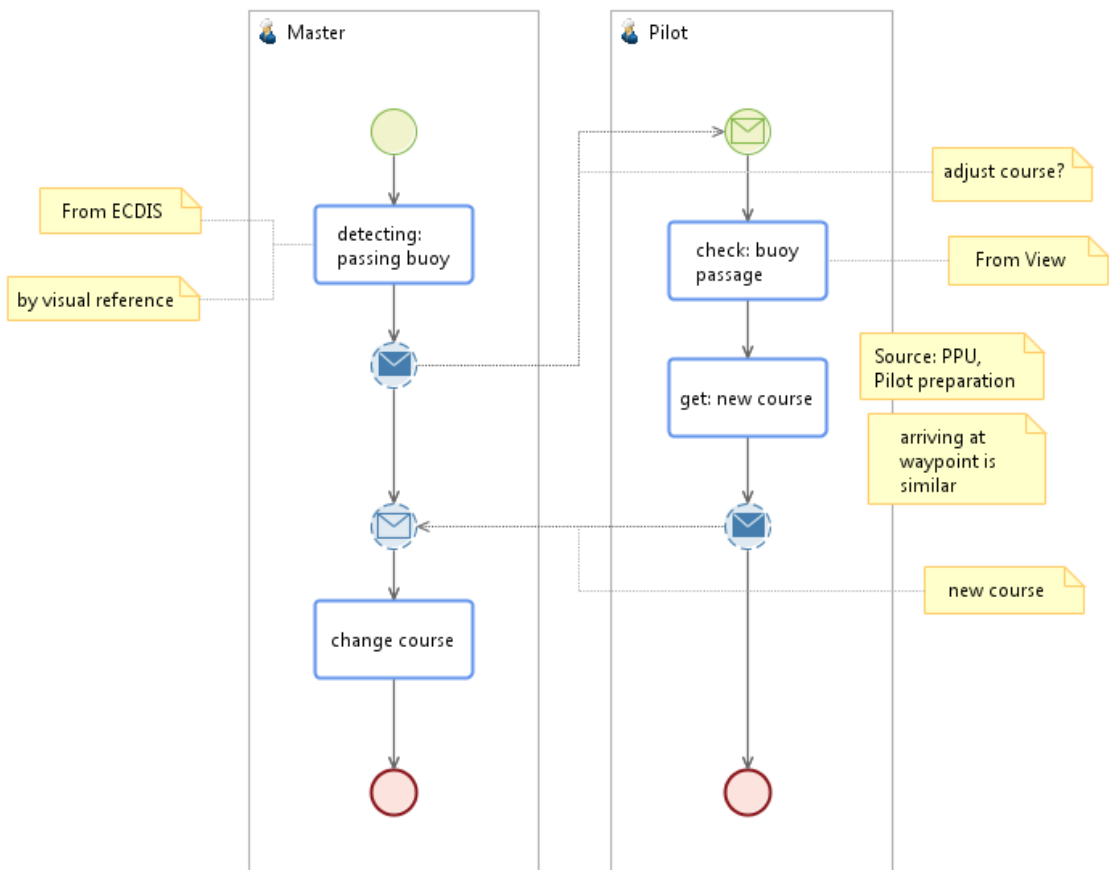

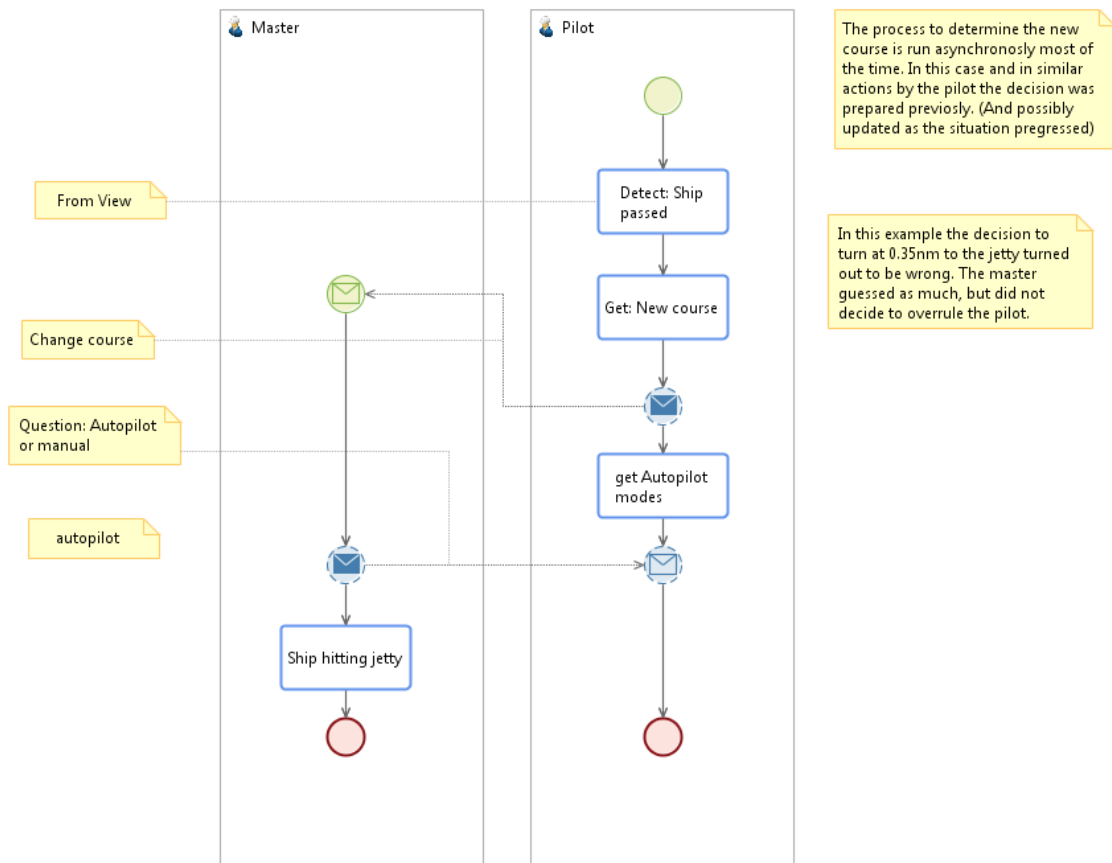
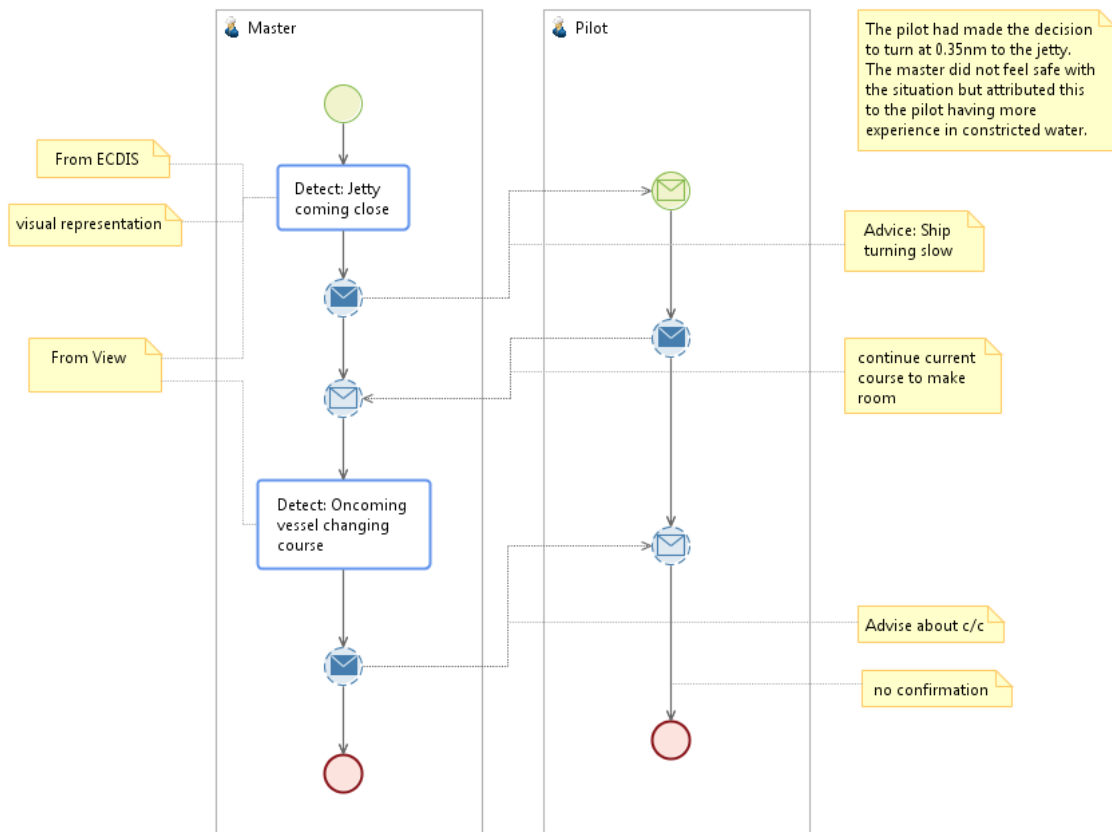

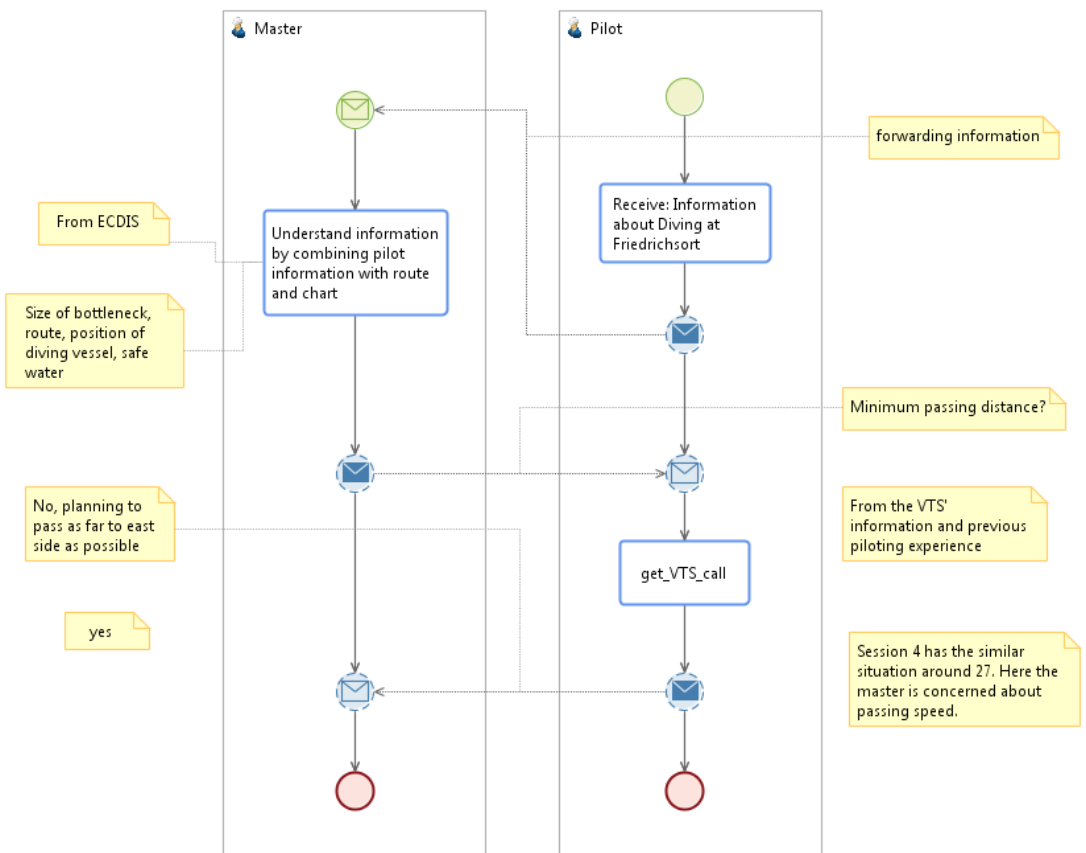
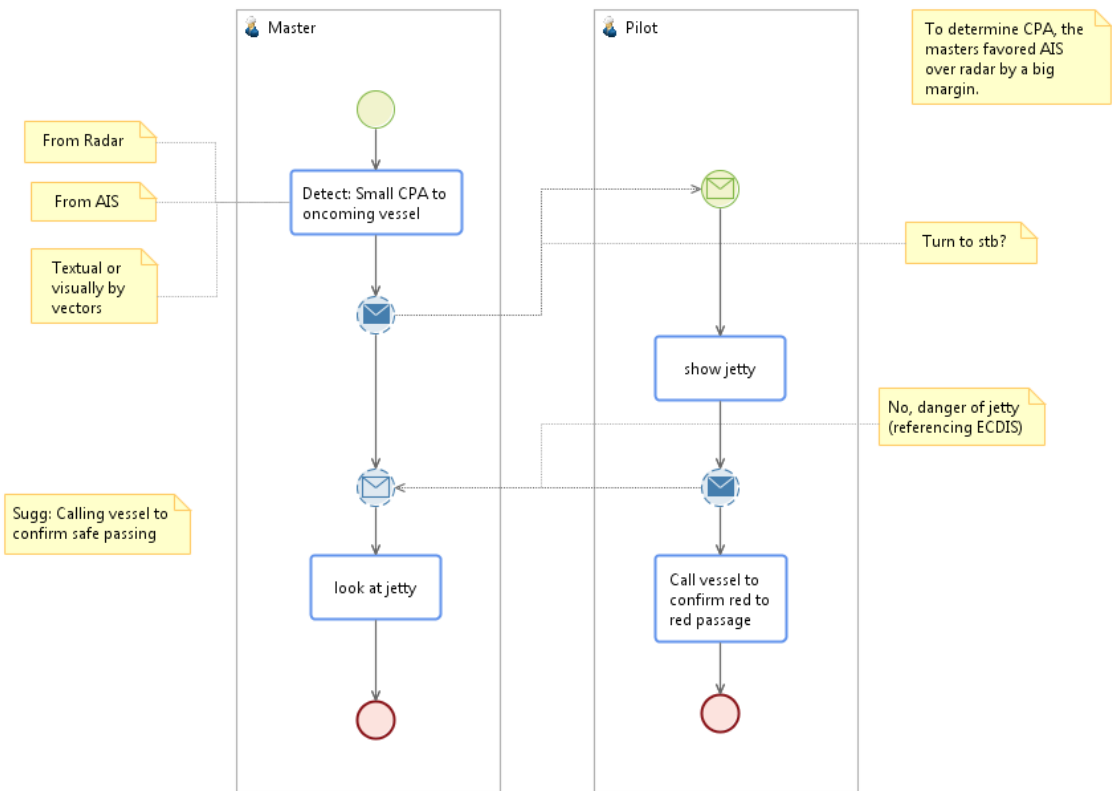

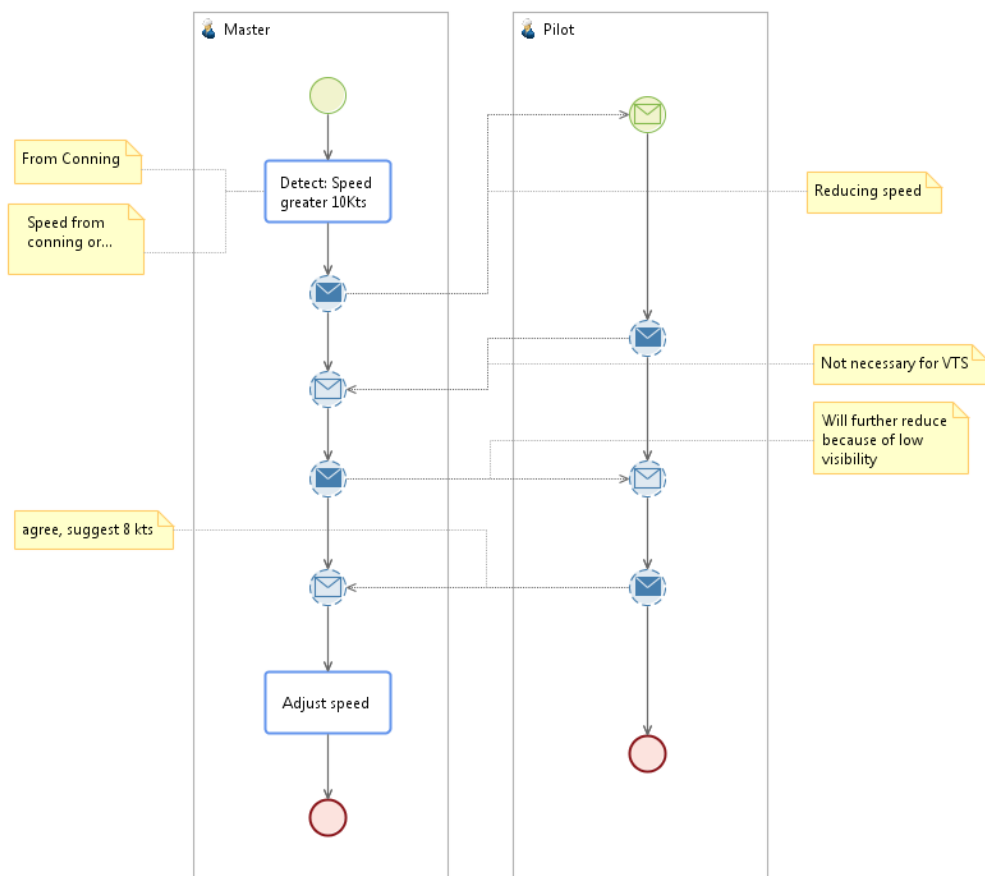
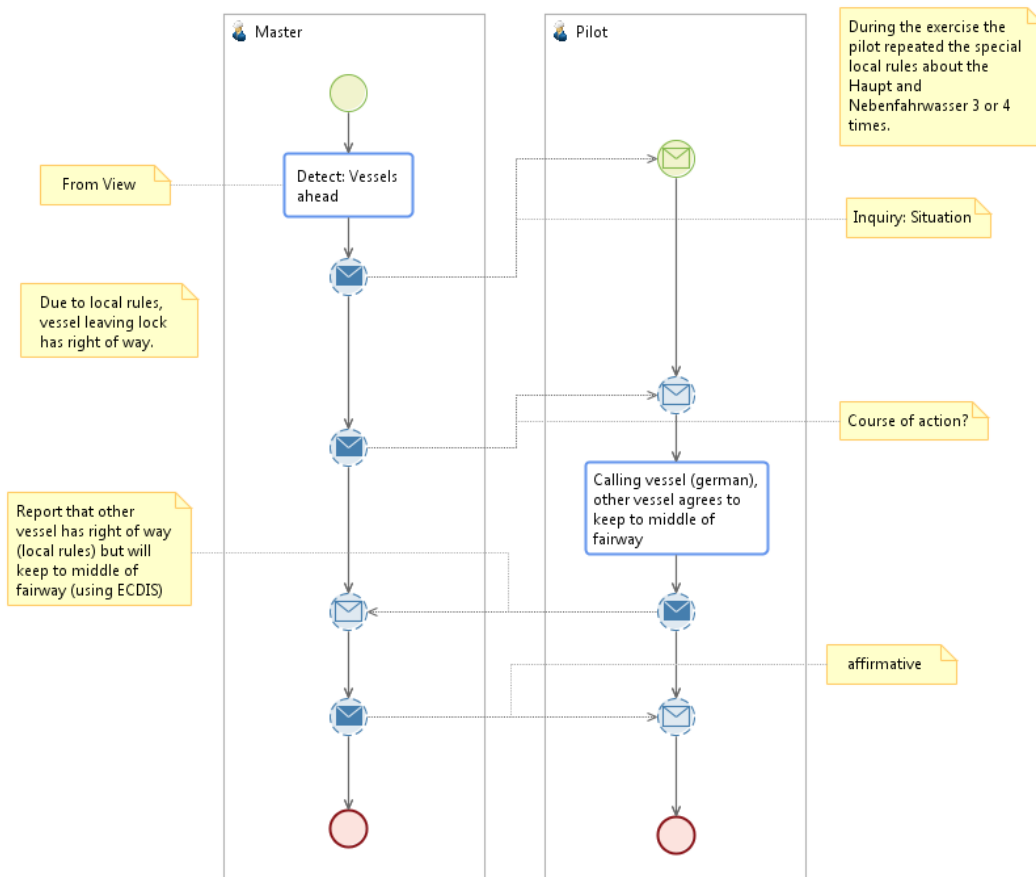

## A.2 Hypotheses 1 and 2 - Information Model

